

# **USER'S MANUAL**



**PPC-7915F/**

**PPC-7917F/**

**PPC-7919F**

**Intel® ATOM N270**

**15" /17" /19" Fanless Panel PC**

**PPC-7915F/PPC-7917F/  
PPC-7919F M1**

***PPC-7915F/PPC-7917F/  
PPC-7919F  
Intel® ATOM N270  
Panel PC System  
With LCD / Touch screen  
OPERATION MANUAL***

**COPYRIGHT NOTICE**

This operation manual is meant to assist both Embedded Computer manufacturers and end users in installing and setting up the system. The information contained in this document is subject to change without any notice.

This manual is copyrighted in January 2010. You may not reproduce or transmit in any form or by any means, electronic, or mechanical, including photocopying and recording.

**ACKNOWLEDGEMENTS**

All trademarks and registered trademarks mentioned herein are the property of their respective owners.

**CE NOTICE**

This is a class A product. In a domestic environment this product may cause radio interference in which case the user may be required to take adequate measures.

---

## **FCC NOTICE**

This equipment has been tested and found to comply with the limits for a Class A digital device, pursuant to part 15 of the FCC Rules. These limits are designed to provide reasonable protection against harmful interference when the equipment is operated in a commercial environment. This equipment generates, uses, and can radiate radio frequency energy and, if not installed and used in accordance with the instruction manual, may cause harmful interference to radio communications. Operation of this equipment in a residential area is likely to cause harmful interference in which case the user will be required to correct the interference at his own expense.

You are cautioned that any change or modifications to the equipment not expressly approve by the party responsible for compliance could void your authority to operate such equipment.

## TABLE OF CONTENTS

### CHAPTER 1 INTRODUCTION

1-1	About This Manual .....	1-2
1-2	Case Illustration .....	1-3
1-2	System Specification .....	1-6
1-3	Safety & Notification .....	1-10

### CHAPTER 2 HARDWARE CONFIGURATION

2-1	Jumper & Connector Quick Reference Table .....	2-2
2-2	Component Locations .....	2-3
2-3	How to Set the Jumpers .....	2-4
2-4	COM Port Connector .....	2-6
2-5	COM1/2/3/4 RI& Voltage Selection .....	2-8
2-6	RS232/422/485(COM2) Selection .....	2-12
2-7	Auto RS485 Selection .....	2-13
2-8	Keyboard and PS/2 Mouse Connector .....	2-14
2-9	Reset Connector .....	2-14
2-10	Hard Disk Drive LED Connector .....	2-15
2-11	ATX Power Button .....	2-15
2-12	External Speaker Connector .....	2-15
2-13	PLed Connector .....	2-16
2-14	Clear CMOS Data Selection .....	2-16
2-15	System Fan Connector .....	2-17
2-16	CPU Fan Connector .....	2-17
2-17	VGA Connector .....	2-18
2-18	Serial ATA Connector .....	2-19
2-19	Printer Connector .....	2-20
2-20	Digital I/O Connector .....	2-21
2-21	USB Connector .....	2-22
2-22	USB & LAN Connector .....	2-23
2-23	ATX Power Connector .....	2-25
2-24	Sound Connector .....	2-26
2-25	LVDS Connector .....	2-27
2-26	Inverter Connector .....	2-29
2-27	LVDS Panel Voltage Selection .....	2-30
2-28	AT/ATX Power Selection .....	2-32
2-29	Reset/NMI Watchdog Selection .....	2-33
2-30	TV Out Connector .....	2-34

---

---

2-31	CF Card Master/ Slave Selection .....	2-34
2-32	Digital Input/ Output Connector .....	2-35
2-33	Memory Installation .....	2-35

**CHAPTER 3 SOFTWARE UTILITIES**

3-1	Introduction .....	3-2
3-2	VGA Driver Utility .....	3-3
3-3	Flash BIOS Update .....	3-4
3-4	LAN Driver Utility .....	3-6
3-5	Sound Driver Utility .....	3-7
3-6	Intel Chipset Software Installation Utility .....	3-8
3-7	Touch Driver Installation Utility .....	3-9
3-8	Watchdog Timer Configuration .....	3-10

**CHAPTER 4 AWARD BIOS SETUP**

4-1	Introduction .....	4-2
4-2	Entering Setup .....	4-3
4-3	The Standard CMOS Features .....	4-4
4-4	The Advanced BIOS Features .....	4-8
4-5	Advanced Chipset Features .....	4-13
4-6	Integrated Peripherals .....	4-16
4-7	Power Management Setup .....	4-22
4-8	PNP/PCI Configuration .....	4-24
4-9	PC Health Status .....	4-26
4-10	Load Fail-Safe Defaults .....	4-27
4-11	Load Optimized Defaults .....	4-27
4-12	Password Setting .....	4-28
4-13	Save & Exit Setup .....	4-29
4-14	Exit Without Saving .....	4-30

**APPENDIX A SYSTEM ASSEMBLY**

	Exploded Diagram of PPC-7915F Whole System .....	A-2
	Exploded Diagram of PPC-7915F Packing .....	A-4
	Exploded Diagram of PPC-7915F Wall Mounting .....	A-6
	Exploded Diagram of PPC-7917F LCD Panel .....	A-9
	Exploded Diagram of PPC-7917F Packing .....	A-11
	Exploded Diagram of PPC-7917F Wall Mounting .....	A-13
	Exploded Diagram of PPC-7919F LCD Panel .....	A-15
	Exploded Diagram of PPC-7919F Packing .....	A-17
	Exploded Diagram of PPC-7919F Wall Mounting .....	A-19

---

**APPENDIX B TECHNICAL SUMMARY**

Block Diagram .....	B-2
Interrupt Map .....	B-3
RTC & CMOS RAM Map .....	B-4
Timer & DMA Channels Map .....	B-5
I/O & Memory Map .....	B-6



# ***INTRODUCTION***

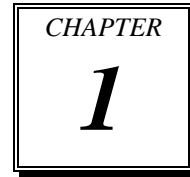

This chapter gives you the information for PPC-7915F/PPC-7917F/PPC-7919F. It also outlines the System specifications.

Section includes:

- About This Manual
- Case Illustration
- System Specifications
- Safety precautions

**Experienced users can skip to chapter 2 on page 2-1 for a Quick Start.**

## **1-1. ABOUT THIS MANUAL**

Thank you for purchasing our Panel PC. It is an updated system designed to be comparable with the highest performance of IBM AT personal computers. It provides faster processing speed, greater expandability, and can handle more tasks. This manual is designed to assist you on how to make the proper installation to set up the system. It contains five chapters. The user can use this manual for configuration according to the following chapters :

### ***Chapter 1 Introduction***

This chapter introduces you to the background of this manual, illustration of the case, and the specifications for this system. The final page of this chapter indicates some safety reminders on how to take care of your system.

### ***Chapter 2 System Configuration***

This chapter outlines the Prox-B587LF components' locations and their functions. In the end of this chapter, you will learn how to set jumper and how to configure the system for your own needs.

### ***Chapter 3 Software Utilities***

This chapter contains helpful information for proper installations of the VGA utility, LAN utility, Sound utility and Flash BIOS update. It also describes the function of the Watchdog Timer.

### ***Chapter 4 Award BIOS Setup***

This chapter indicates on how to set up the BIOS configurations.

### ***Appendix A System Assembly***

This section gives you the exploded diagram for the whole system unit.

### ***Appendix B Technical Summary***

This section gives you the information about the Technical maps.



### 1-2. CASE ILLUSTRATION

**Note:** When insert this computer into any machine or wall, user should left at least 5cm space for thermal issue.

#### PPC-7915F

Front View

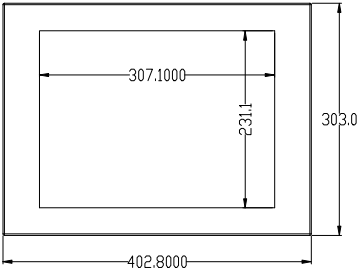

Rear View

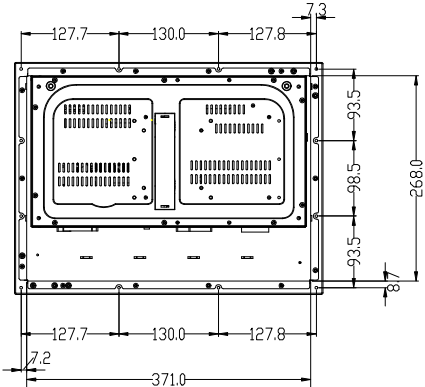

Top View

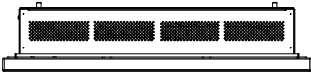

Side View

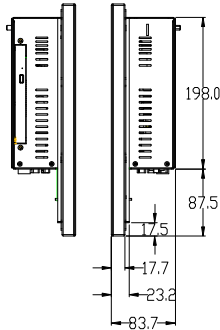

Bottom View

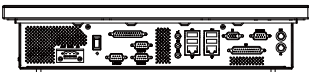

**PPC-7917F**

Front View

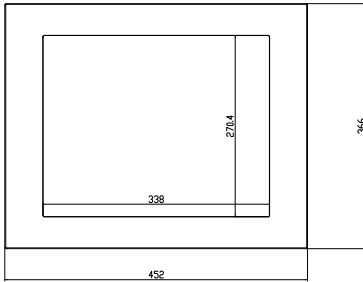

Rear View

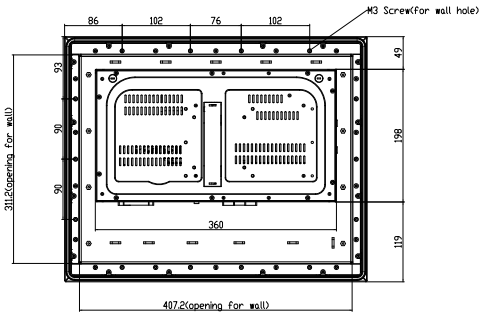

Top View

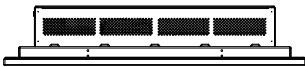

Side View

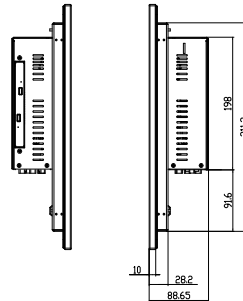

Bottom View

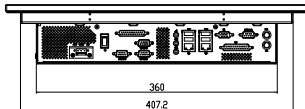

PPC-7919F

Front View

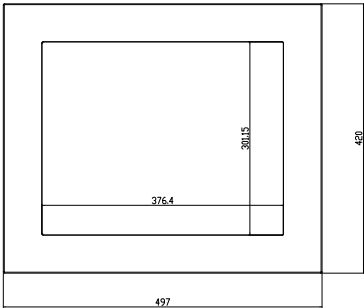

Rear View

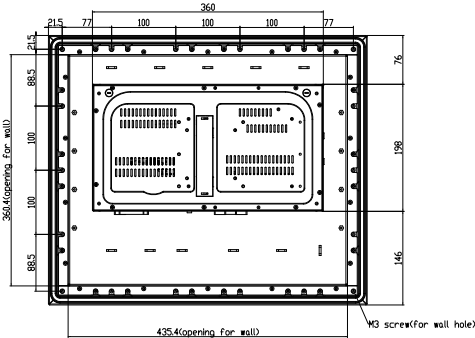

Top View

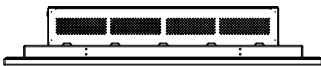

Bottom View

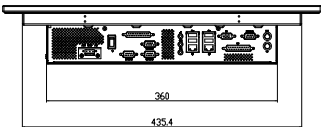

Side View

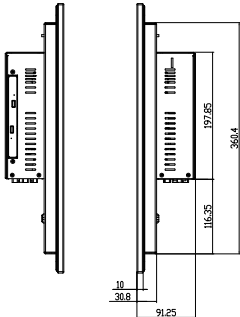

## **1-3. SYSTEM SPECIFICATIONS**

### **MAINBOARD (PROX-B587LF)**

- **CPU TYPE:**
  - Intel® ATOM N270 CPU (1.6GHz)
  - Auto detect voltage regulator.
  
- **CHIPSET:**
  - Intel® 945GSE + ICH7M (FSB: 533MHz)
  
- **MEMORY :**
  - 1 x 200-pin DDR2 SO-DIMM. Support DDR II 533 SDRAM up to 2GB.
  
- **CACHE :**
  - Built-in CPU
  
- **REAL-TIME CLOCK :**
  - 256-byte battery backed CMOS RAM.
  - Hardware implementation to indicate century rollover.
  
- **BIOS :**
  - Phoenix-AwardBIOS™ for plug & play function
  - 4Mbytes with VGA BIOS
  - Easy update 512KB flash EEPROM
  - Support S/IO Setup
  
- **KEYBOARD CONNECTOR :**
  - Mini DIN connector.
  - Supports for AT/PS2 keyboard.
  
- **MOUSE CONNECTOR :**
  - Mini DIN connector.
  - Supports PS/2 Mouse.
  
- **BUS SUPPORT :**
  - 1 PCI-E (x1) Slot, 1 x Mini-PCI Slot, 1 x CF Slot

● **DISPLAY :**

PPC-7915F 15" LCD Panel XGA 1024 x 768  
PPC-7917F 17" LCD Panel SXGA 1280 x 1024  
PPC-7919F 19" LCD Panel SXGA 1280 x 1024

● **WATCHDOG :**

1~255 seconds Watchdog timer selectable w/Reset/NMI.

● **SERIAL PORT :**

Four high speed 16550 Compatible UARTs with Send / Receive 16 Byte FIFOs.  
COM1, COM3, COM4 for RS-232;  
COM2 for RS-232/422/485;  
MIDI Compatible  
Programmable BaudRate Generator

● **LAN ADAPTER :**

Marvell LAN Chip (10/100/1000 Mbps).  
Support Wake-On-LAN function.

● **USB CONNECTOR :**

External: 4 USB ports.  
Internal: 4 USB ports (one for Touch control board)

● **SOUND :**

Realtek ALC888 (High Definition Audio).  
Interface: Line\_IN, Line\_OUT, MIC\_IN

● **HARDWARE MONITORING FUNCTION :**

Monitor Voltage, CPU temperature & cooling fan speed.  
If CPU temperature is over setting the buzzer will send out a warning (only under DOS system)

## **LCD PANEL**

- **LCD TYPE :**  
According to the supplier's LCD specification.
- **PIXEL PITCH :**  
According to the supplier's LCD specification.
- **BRIGHTNESS :**  
According to the supplier's LCD specification.
- **CONTRAST RATIO :**  
According to the supplier's LCD specification.
- **POWER CONSUMPTION :**  
According to the supplier's LCD specification.
- **VIEWING ANGLE :**  
According to the supplier's LCD specification.
- **RESPONSE TIME :**  
According to the supplier's LCD specification.
- **COLOR :**  
According to the supplier's LCD specification.
- **LCD MTBF :**  
According to the supplier's LCD specification.
- **BACKLIGHT MTBF :**  
According to the supplier's LCD specification.
- **DIMENSION :**  
According to the supplier's LCD specification.

**TOUCH SCREEN :**

Type	Resistive
Resolution	PPC-7915F : 4096 x 4096 PPC-7917F : 4096 x 4096 PPC-7919F : 4096 x 4096
Hardness	PPC-7915F : 3H PPC-7917F : 3H PPC-7919F : 3H
Controller	USB interface
Knock Life	35,000,000 Times
Input Voltage	5V
Wire	5 Wire

**GENERAL INFORMATION**

● **POWER SUPPLY :**

DC 24V, 5A input

● **DRIVE BAYS :**

1x Slim HDD

1x Compact Flash Type-II Slot (IDE, On Board)

1x Slim CDROM (optional)

● **CONSTRUCTION :**

Electro Galvanized steel chassis.

Stainless steel front bezel.

● **DIMENSIONS :**

PPC-7915F : 403 x 303 x 84mm (15.87"x11.93"x3.31")

PPC-7917F : 452 x 366 x 89mm (17.8" x 14.4" x 3.5")

PPC-7919F : 497 x 420 x 91.5mm (19.65" x 16.5" 3.6")

● **NET WEIGHT :**

PPC-7915F : 6.6 KG (14.55 lb)

PPC-7917F : 8.8 KG (19.40 lb)

PPC-7919F : 10.8 KG (23.81 lb)

## **1-4. SAFETY AND NOTIFICATION**

Following messages are safety reminders on how to protect your systems from damages. And thus, helps you lengthen the life cycle of the system.

### **1. Check the Line Voltage**

- a. The operating voltage for the power supply should cover the range of AC 100V~240V, otherwise the system may be damaged.

### **2. Environmental Conditions**

- a. Place your PPC-7915F/PPC-7917F/PPC-7919F on a sturdy, level surface. Be sure to allow enough room on each side to have easy access.
- b. Avoid extremely hot or cold places to install your PPC.
- c. Avoid exposure to sunlight for a long period of time (for example in a closed car in summer time. Also avoid the system from any heating device.). Or do not use PPC-7915F/PPC-7917F/PPC-7919F when it's been left outdoors in a cold winter day.
- d. Bear in mind that the operating ambient temperature is from 0°C up to +40°C.
- e. Avoid moving the system rapidly from a hot place to a cold place or vice versa because condensation may come from inside of the system.
- f. Place PPC-7915F/PPC-7917F/PPC-7919F against strong vibrations, which may cause hard disk failure.
- g. Do not place the system too close to any radio active device. Radioactive device may cause interference.

### **3. Handling**

- a. Avoid putting heavy objects on top of the system.
- b. Do not turn the system upside down. This may cause the floppy drive and hard drive to mal-function.
- c. Do not remove the diskette from the Floppy drive while the light is still on.



If you remove the diskette while the light is on, you may damage the information on the diskette.

**4. Good Care**

- a. When the outside of the case is stained, remove the stain with neutral washing agent with a dry cloth.
- b. Never use strong agents such as benzene and thinner to clean the system.
- c. If heavy stains are present, moisten a cloth with diluted neutral washing agent or with alcohol and then wipe thoroughly with a dry cloth.
- d. If dust has been accumulated on the outside, remove it by using a special made vacuum cleaner for computers.

# ***HARDWARE CONFIGURATION***

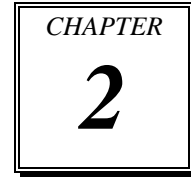

## ***\*\* QUICK START \*\****

Helpful information describes the jumper & connector settings, and component locations.

Section includes:

- Jumper & Connector Quick Reference Table
- Component Locations
- Configuration and Jumper settings
- Connector's Pin Assignments

## 2-1. JUMPER & CONNECTOR QUICK REFERENCE TABLE

COM Port Connector .....	COM1, COM2, COM3, COM4
COM1/2/3/4 Port RI/Voltage Selection .....	JP_COM1, JP_COM2, JP8, JP7
RS232/422/485 (COM2) Selection .....	JP10
Auto RS485 Selection .....	JP11
Keyboard/Mouse Connector .....	KB_MS1
Reset Connector .....	JANEL1 ( 9 , 11 )
Hard Disk Drive LED Connector .....	JANEL1 ( 5 , 7 )
Power Button .....	JANEL1 ( 10 , 12 )
External Speaker Connector .....	JANEL1 ( 1 , 3 )
PLED Connector .....	JANEL1 ( 4 , 6 , 8 )
Clear CMOS Data Selection .....	JP4
System Fan Connector .....	FAN1
CPU Fan Connector .....	CPU_FAN1
VGA Connector .....	VGA1
Serial ATA Connector .....	SATA1, SATA2
Printer Connector .....	JPRNT1
Digital I/O Connector .....	Digital I/O
Universal Serial Bus Connector .....	JUSB1, JUSB2
USB & LAN Connector .....	JRJ45USB1, JRJ45USB2
ATX Power Connector .....	JATX_PWR1
Sound Connector .....	JAUDIO1
LVDS Connector .....	LVDS1, LVDS2
Inverter Connector .....	INV1, INV2
LVDS Panel Voltage Selection .....	JP_LV1, JP_LV2
AT/ATX Power Selection .....	JP6, JP12, JP13
Reset/NMI Selection .....	JP9
TV Out Connector .....	JTV1
CF Card Master/ Slave Selection .....	JP5
Digital Input/ Output Connector .....	DIO_C1
Memory Installation .....	DIM1
Reserved Pin .....	JP3

## 2-2. COMPONENT LOCATIONS

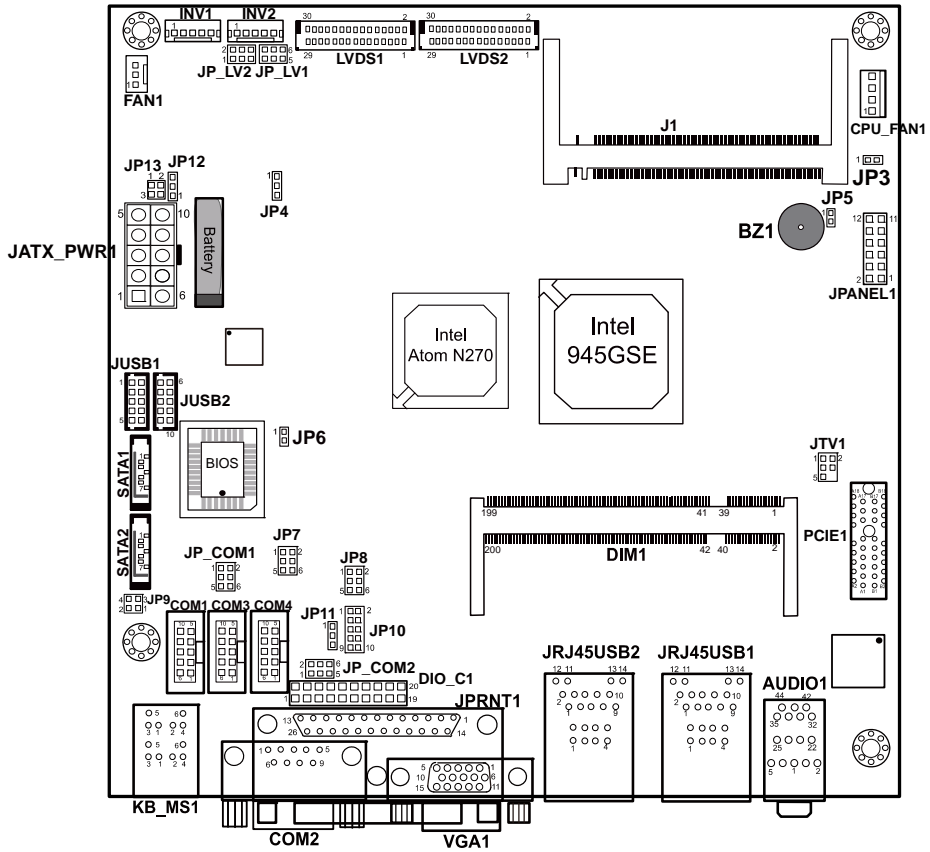

**PPC-7915F/PPC-7917F/PPC-7919F Connector, Jumper and Component locations**

## **2-3. HOW TO SET THE JUMPERS**

You can configure your board by setting jumpers. Jumper is consists of two or three metal pins with a plastic base mounted on the card, and by using a small plastic "cap", Also known as the jumper cap (with a metal contact inside), you are able to connect the pins. So you can set-up your hardware configuration by "open" or "close" pins.

The jumper can be combined into sets that called jumper blocks. When the jumpers are all in the block, you have to put them together to set up the hardware configuration. The figure below shows how this looks like.

### **JUMPERS AND CAPS**

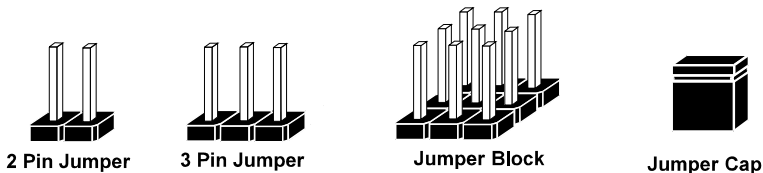

If a jumper has three pins (for examples, labelled PIN1, PIN2, and PIN3), You can connect PIN1 & PIN2 to create one setting by shorting. You can either connect PIN2 & PIN3 to create another setting. The same jumper diagrams are applied all through this manual. The figure below shows what the manual diagrams look and what they represent.

**JUMPER DIAGRAMS**



Jumper Cap  
looks like this



2 pin Jumper  
looks like this

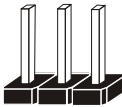

3 pin Jumper  
looks like this



Jumper Block  
looks like this

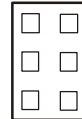

**JUMPER SETTINGS**



2 pin Jumper close(enabled)  
Looks like this



1



3 pin Jumper  
2-3 pin close(enabled)  
Looks like this



1



Jumper Block  
1-2 pin close(enabled)  
Looks like this

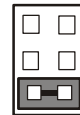

1 2

## 2-4. COM PORT CONNECTOR

**COM1** : COM1 Connector

COM1 is fixed as RS-232.

The pin assignment is as follows :

PIN	ASSIGNMENT
1	DCD1
2	RX1
3	TX1
4	DTR1
5	GND
6	DSR1
7	RTS1
8	CTS1
9	RI1

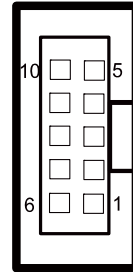

**COM1**

**COM2** : COM2 Connector

The COM2 is selectable as RS-232/422/485.

The pin assignment is as follows :

PIN	ASSIGNMENT		
	RS-232	RS-422	RS-485
1	DCD2	TX-	TX-
2	RX2	TX+	TX+
3	TX2	RX+	RX+
4	DTR2	RX-	RX-
5	GND	GND	GND
6	DSR2	RTS-	GND
7	RTS2	RTS+	GND
8	CTS2	CTS+	GND
9	RI2	CTS-	GND

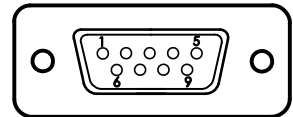

**COM2**

**COM3** : COM3 Connector

COM3 is fixed as RS-232.

The pin assignment is as follows :

PIN	ASSIGNMENT
1	DCD3
2	RX3
3	TX3
4	DTR3
5	GND
6	DSR3
7	RTS3
8	CTS3
9	RI3

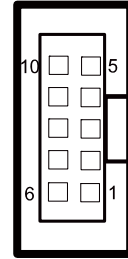

**COM3**

 COM3's pin 9 is selectable for RI, +5V or +12V. For more information, please refer to our "2-5 COM RI and Voltage Selection".

**COM4** : COM4 Connector

COM4 is fixed as RS-232.

The pin assignment is as follows :

PIN	ASSIGNMENT
1	DCD4
2	RX4
3	TX4
4	DTR4
5	GND
6	DSR4
7	RTS4
8	CTS4
9	RI4

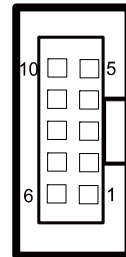

**COM4**

 COM4's pin 9 is selectable for RI, +5V or +12V. For more information, please refer to our "2-5 COM RI and Voltage Selection".



**2-5. COM1/2/3/4 RI & VOLTAGE SELECTION**

**JP\_COM1** : COM1 RI & Voltage Selection

The selections are as follows:

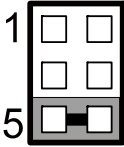
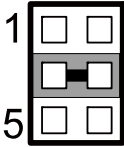
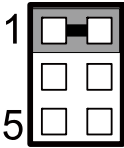
COM	SELECTION	JUMPER SETTINGS	JUMPER ILLUSTRATION
COM1	5V	5-6	 <p><b>JP_COM1</b></p>
	12V	3-4	 <p><b>JP_COM1</b></p>
	RI	1-2	 <p><b>JP_COM1</b></p>

\*\*\*Manufacturing Default -- RI.

**JP\_COM2** : COM2 RI & Voltage Selection

The selections are as follows:

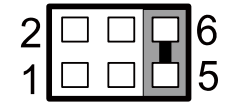
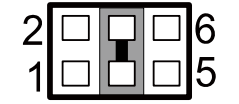
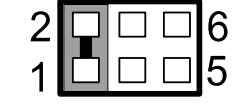
COM	SELECTION	JUMPER SETTINGS	JUMPER ILLUSTRATION
COM2	5V	5-6	 <p>JP_COM2</p>
	12V	3-4	 <p>JP_COM2</p>
	RI	1-2	 <p>JP_COM2</p>

\*\*\*Manufacturing Default -- RI.

**JP8 : COM3 RI & Voltage Selection**

The selections are as follows:

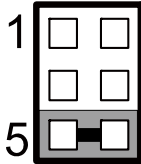
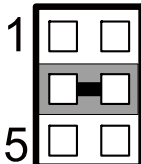
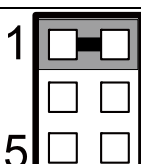
COM	SELECTION	JUMPER SETTINGS	JUMPER ILLUSTRATION
COM3	5V	5-6	 <p><b>JP8</b></p>
	12V	3-4	 <p><b>JP8</b></p>
	RI	1-2	 <p><b>JP8</b></p>

\*\*\*Manufacturing Default -- RI.

**JP7** : COM4 RI & Voltage Selection

The selections are as follows:

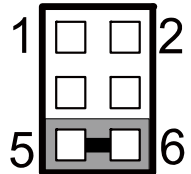
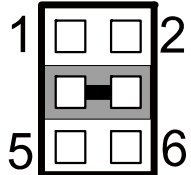
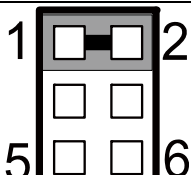
COM	SELECTION	JUMPER SETTINGS	JUMPER ILLUSTRATION
COM4	5V	5-6	 <p><b>JP7</b></p>
	12V	3-4	 <p><b>JP7</b></p>
	RI	1-2	 <p><b>JP7</b></p>

\*\*\*Manufacturing Default -- RI.

## 2-6. RS232/422/485 (COM2) SELECTION

### JP10 : RS-232/422/485 (COM2) Selection

This connector is used to set the COM2 function.

The jumper settings are as follows :

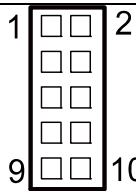
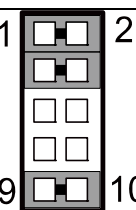
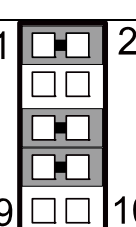
COM 2 Function	Jumper Settings (pin closed)	Jumper Illustrations
RS-232	All Open	 <p><b>JP10</b></p>
RS-422	1-2, 3-4, 9-10	 <p><b>JP10</b></p>
RS-485	1-2, 5-6, 7-8	 <p><b>JP10</b></p>

\*\*\* Manufacturing default -- RS-232.

## 2-7. AUTO RS485 SELECTION

**JP11** : RS-232/422/485 (COM2) Selection

COM2 is selectable for RS-232, 422, 485 function.

The jumper settings are as follows :

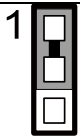
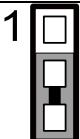
COM 2 FUNCTION	JUMPER SETTING (pin closed)	JUMPER ILLUSTRATION
Auto 485 (default)	1-2	 <p><b>JP11</b></p>
No Auto 485	2-3	 <p><b>JP11</b></p>

\*\*\* Manufacturing default – Auto 485.

## 2-8. KEYBOARD AND PS/2 MOUSE CONNECTOR

**KB\_MS1** : Keyboard and PS/2 Mouse Connector

The pin assignments are as follows :

PIN	ASSIGNMENT
1	KBDATA
2	NC
3	GND
4	5VSB
5	KBCLK
6	NC
7	MSDATA
8	NC
9	GND
10	5VSB
11	MSCLK
12	NC

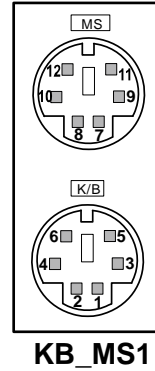

## 2-9. RESET CONNECTOR

**JANEL1 (9, 11)** : Reset Connector.

The pin assignment is as follows :

PIN	ASSIGNMENT
9	GND
11	RST_BTN

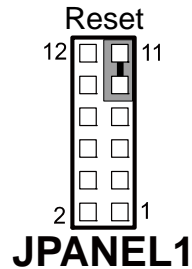

## 2-10. HARD DISK DRIVE LED CONNECTOR

**JANEL1 (5, 7) :** Hard Disk Drive LED Connector  
The pin assignment is as follows :

PIN	ASSIGNMENT
5	HD_LED+
7	HD_LED-

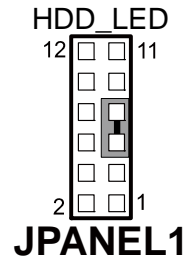

## 2-11. ATX POWER BUTTON

**JANEL1 (10, 12) :** ATX Power Button  
The pin assignment is as follows :

PIN	ASSIGNMENT
10	PW_BN1
12	PW_BN2

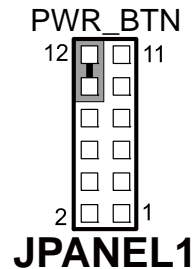

## 2-12. EXTERNAL SPEAKER CONNECTOR

**JANEL1 (1, 3) :** External Speaker Connector  
The pin assignment is as follows :

PIN	ASSIGNMENT
1	P_SPK
3	VCC

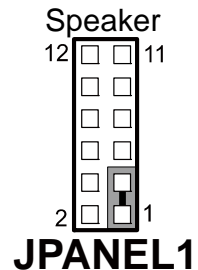



### 2-13. PLED CONNECTOR

**JPANEL1 (4, 6, 8) :** PLED Connector  
 The pin assignment is as follows:

PIN	ASSIGNMENT
4	PW_LED+
6	PW_LED+
8	PW_LED-

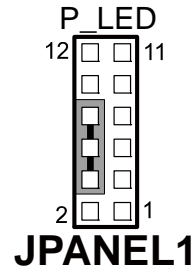

### 2-14. CLEAR CMOS DATA SELECTION

**JP4 :** Clear CMOS Data Selection  
 The selections are as follows :

FUNCTION	JUMPER SETTING (pin closed)	JUMPER ILLUSTRATION
Normal	1-2	<p><b>JP4</b></p>
Clear CMOS	2-3	<p><b>JP4</b></p>

\*\*\* Manufacturing Default -- Normal.

Note: To clear CMOS data, user must power-off the computer and set the jumper to “Clear CMOS” as illustrated above. After five to six seconds, set the jumper back to “Normal” and power-on the computer.

## 2-15. SYSTEM FAN CONNECTOR

**FAN1** : System Fan connector  
The pin assignment is as follows:

PIN	ASSIGNMENT
1	FANPWM1
2	+12V
3	FAN1

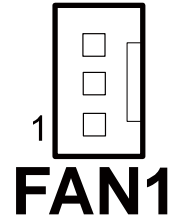

## 2-16. CPU FAN CONNECTOR

**CPU\_FAN1** : CPU Fan connector  
The pin assignment is as follows:

PIN	ASSIGNMENT
1	GND
2	VCC12
3	LPC1_FANIO1
4	LPC1_FANPWM1

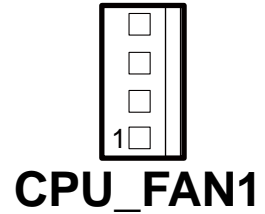

## 2-17. VGA CONNECTOR

**VGA1:** VGA Connector

The pin assignments are as follows:

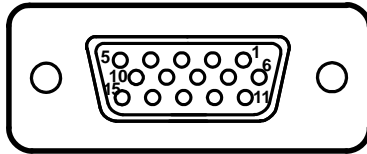

### VGA1

PIN	ASSIGNMENT
1	RED
2	GREEN
3	BLUE
4	NC
5	GND
6	GND
7	GND
8	GND
9	VCC
10	GND
11	NC
12	VGA IIC DATA
13	HSYNC
14	VSYNC
15	VGA IIC CLK

## 2-18. SERIAL ATA CONNECTOR

**SATA1~SATA2:** The PPC-7915F/PPC-7917F/PPC-7919F possesses two Serial ATA Connector, SATA1~SATA2. The pin assignments are as follows:

**SATA1 :** SATA Connector

The pin assignments are as follows :

PIN	ASSIGNMENT
1	GND
2	SATA_TXPC0
3	SATA_TXNC0
4	GND
5	SATA_RXNC0
6	SATA_RXPC0
7	GND

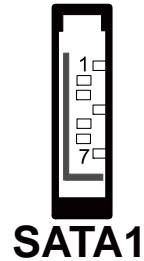

**SATA2 :** SATA Connector

The pin assignments are as follows :

PIN	ASSIGNMENT
1	GND
2	SATA_TXPC1
3	SATA_TXNC1
4	GND
5	SATA_RXNC1
6	SATA_RXPC1
7	GND

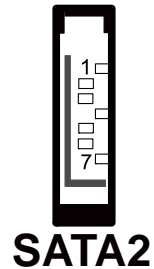

## 2-19. PRINTER CONNECTOR

**JPRNT1:** Printer Connector

The pin assignments are as follows :

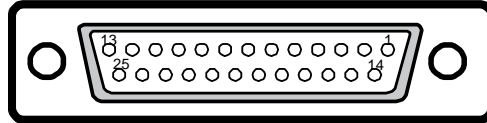

**JPRNT1**

PIN	ASSIGNMENT	PIN	ASSIGNMENT
1	RSTBJ	14	AFDJ
2	RPD0	15	ERRJ
3	RPD1	16	PAR_INITJ
4	RPD2	17	SLINJ
5	RPD3	18	GND
6	RPD4	19	GND
7	RPD5	20	GND
8	RPD6	21	GND
9	RPD7	22	GND
10	ACKJ	23	GND
11	BUSY	24	GND
12	PE	25	GND
13	SLCT		

## 2-20. DIGITAL I/O CONNECTOR

**Digital I/O:** Digital I/O Connector

The pin assignments are as follows :

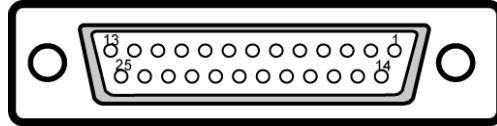

**Digital I/O**

PIN	ASSIGNMENT	PIN	ASSIGNMENT
1	DIN0	14	DOUT5
2	DIN1	15	DOUT6
3	DIN2	16	DOUT7
4	DIN3	17	VCC
5	DIN4	18	VCC
6	DIN5	19	GND
7	DIN6	20	GND
8	DIN7	21	NC
9	DOUT0	22	NC
10	DOUT1	23	NC
11	DOUT2	24	NC
12	DOUT3	25	NC
13	DOUT4		

## 2-21. UNIVERSAL SERIAL BUS CONNECTOR

**JUSB1** : Universal Serial Bus Connector

The pin assignments are as follows :

PIN	ASSIGNMENT
1	VCCUSB4
2	USBP4N
3	USBP4P
4	GND
5	NC
6	VCCUSB5
7	USBP5N
8	USBP5P
9	GND
10	NC

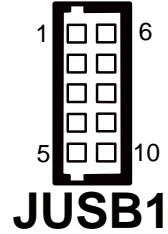

**JUSB2** : Universal Serial Bus Connector

The pin assignments are as follows :

PIN	ASSIGNMENT
1	VCCUSB6
2	USBP6N
3	USBP6P
4	GND
5	NC
6	VCCUSB7
7	USBP7N
8	USBP7P
9	GND
10	NC

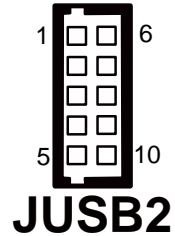

## 2-22. USB&LAN CONNECTOR

**JRJ45USB1** : USB & LAN Connector

The pin assignments are as follows :

LAN Signal :

PIN	ASSIGNMENT
1	VCC_LAN1
2	LAN1_MDI_0P
3	LAN1_MDI_0N
4	LAN1_MDI_1P
5	LAN1_MDI_1N
6	LAN1_MDI_2P
7	LAN1_MDI_2N
8	LAN1_MDI_3P
9	LAN1_MDI_3N
10	COM_LAN1

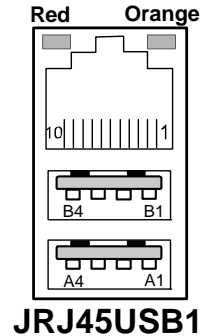

LAN LED Indicator:

Left Side LED

RED Color On	Giga LAN Speed Indicator
Off	No LAN switch/ hub connected.

Right Side LED

Orange Color Blinking	LAN Message Active
Off	No LAN Message Active

USB Signal :

PIN	ASSIGNMENT
A1	VCCUSB1
A2	USBP1N
A3	USBP1P
A4	GND
B1	VCCUSB0
B2	USBP0N
B3	USBP0P
B4	GND



**JRJ45USB2 : USB & LAN Connector**

The pin assignments are as follows :

LAN Signal :

PIN	ASSIGNMENT
1	VCC_LAN2
2	LAN2_MDI_0P
3	LAN2_MDI_0N
4	LAN2_MDI_1P
5	LAN2_MDI_1N
6	LAN2_MDI_2P
7	LAN2_MDI_2N
8	LAN2_MDI_3P
9	LAN2_MDI_3N
10	COM_LAN2

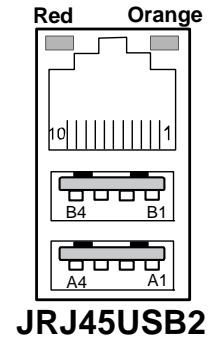

LAN LED Indicator:

Left Side LED

RED Color On	Giga LAN Speed Indicator
Off	No LAN switch/ hub connected.

Right Side LED

Orange Color Blinking	LAN Message Active
Off	No LAN Message Active

USB Signal :

PIN	ASSIGNMENT
A1	VCCUSB3
A2	USBP3N
A3	USBP3P
A4	GND
B1	VCCUSB2
B2	USBP2N
B3	USBP2P
B4	GND

## 2-23. ATX POWER CONNECTOR

**JATX\_PWR1:** Power Connector  
The pin assignments are as follows :

PIN	ASSIGNMENT
1	5V
2	5V
3	GND
4	GND
5	12V
6	5VSB
7	5V
8	GND
9	PS_ON
10	-12V

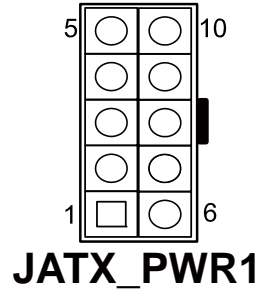

## 2-24. SOUND CONNECTOR

### JAUDIO1 : Sound Connector

The pin assignments are as follows :

#### Line-In

PIN	ASSIGNMENT
32	LINE_L
33	GND
34	GND
35	LINE_R

#### Line-Out

PIN	ASSIGNMENT
22	SPK_L
23	NC
24	NC
25	SPK_R

#### Mic-In

PIN	ASSIGNMENT
1	GND
2	MIC_IN1
3	NC
4	NC
5	MIC_IN2

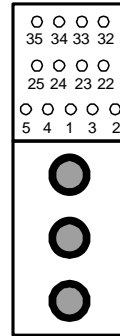

**JAUDIO1**

## 2-25. LVDS CONNECTOR

LVDS1 : LVDS1 CONNECTOR

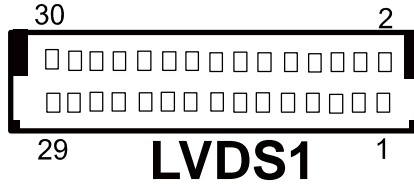

The pin assignments are as follows :

PIN	ASSIGNMENT	PIN	ASSIGNMENT
1	LCD_VCC	2	GND
3	ZCM	4	ZCP
5	GND	6	Z2M
7	Z2P	8	GND
9	Z1M	10	Z1P
11	Z3P	12	Z3M
13	Z0P	14	Z0M
15	GND	16	YCP
17	YCM	18	GND
19	Y2P	20	Y2M
21	GND	22	Y1P
23	Y1M	24	GND
25	Y0P	26	Y0M
27	Y3P	28	Y3M
29	LCD_VCC	30	LCD_VCC

**LVDS2 : LVDS2 CONNECTOR**

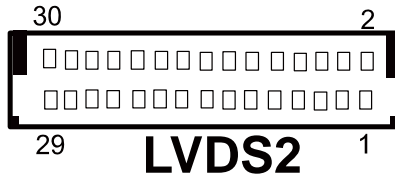

The pin assignments are as follows :

<b>PIN</b>	<b>ASSIGNMENT</b>	<b>PIN</b>	<b>ASSIGNMENT</b>
1	LCD_VCC	2	GND
3	ZCM	4	ZCP
5	GND	6	Z2M
7	Z2P	8	GND
9	Z1M	10	Z1P
11	Z3P	12	Z3M
13	Z0P	14	Z0M
15	GND	16	YCP
17	YCM	18	GND
19	Y2P	20	Y2M
21	GND	22	Y1P
23	Y1M	24	GND
25	Y0P	26	Y0M
27	Y3P	28	Y3M
29	LCD_VCC	30	LCD_VCC

## 2-26. INVERTER CONNECTOR

**INV1** : Inverter1 Connector

The pin assignments are as follows :

PIN	ASSIGNMENT
1	+12V
2	GND
3	VCC
4	GND
5	ENABKL (Inverter Backlight ON/OFF Control Signal)

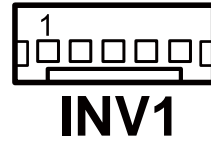

**INV2** : Inverter2 Connector

The pin assignments are as follows :

PIN	ASSIGNMENT
1	+12V
2	GND
3	VCC
4	GND
5	ENABKL (Inverter Backlight ON/OFF Control Signal)

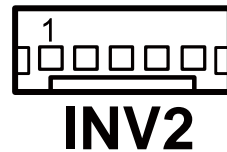

## 2-27. LVDS PANEL VOLTAGE SELECTION

**JP\_LV1** : LVDS1 Panel Voltage Selection.

The pin assignments are as follows :

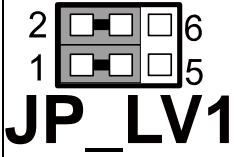
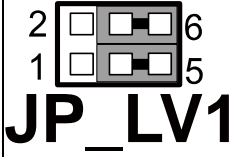
SELECTION	JUMPER SETTING (pin closed)	JUMPER ILLUSTRATION
LVDS_VCC3	1-3 2-4	 <b>JP_LV1</b>
LVDS_VCC5	3-5 4-6	 <b>JP_LV1</b>

\*\*\* Manufacturing Default – LVDS\_VCC3.

**JP\_LV2** : LVDS2 Panel Voltage Selection.

The pin assignments are as follows :

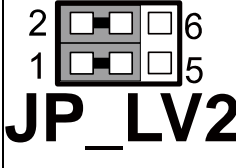
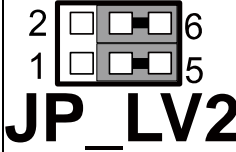
SELECTION	JUMPER SETTING (pin closed)	JUMPER ILLUSTRATION
LVDS_VCC3	1-3 2-4	 <p style="text-align: center;"><b>JP_LV2</b></p>
LVDS_VCC5	3-5 4-6	 <p style="text-align: center;"><b>JP_LV2</b></p>

\*\*\* Manufacturing Default – LVDS\_VCC3.



**2-28. AT/ ATX POWER SELECTION**

**JP6, JP12, JP13** : AT/ ATX Power Selections.

The pin assignments are as follows :

Selections	Jumper Setting			Jumper Illustrations
	JP6	JP12	JP13	
ATX	1-2	1-2	Open	<p><b>JP13 JP12 JP6</b></p>
AT	Open	2-3	1-2 3-4	<p><b>JP13 JP12 JP6</b></p>

\*\*\* Manufacturing Default – ATX.

## 2-29. RESET/ NMI SELECTIONS

**JP9** : Watchdog Timer Selections.

The pin assignments are as follows :

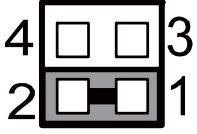
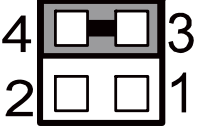
Selections	Jumper Setting	Jumper Illustration
RESET	1-2	 <p><b>JP9</b></p>
NMI	3-4	 <p><b>JP9</b></p>

\*\*\* Manufacturing Default – NMI

### 2-30. TV OUT CONNECTOR

**JTV1** : TV OUT CONNECTOR

The pin assignments are as follows :

PIN	ASSIGNMENT
1	Luminance(Y)
2	CVBS
3	GND
4	GND
5	Chrominance(UV)

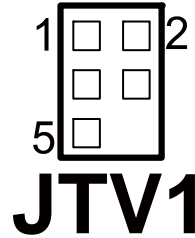

### 2-31. CF CARD MASTER/SLAVE SELECTION

**JP5** : CF Card Master/ Slave Selection.

The pin assignments are as follows :

Selections	Jumper Setting	Jumper Illustration
Master	Close	<p><b>JP5</b></p>
Slave	Open	<p><b>JP5</b></p>

\*\*\* Manufacturing Default – Master.

## 2-32. DIGITAL INPUT/OUTPUT CONNECTOR

**DIO\_C1** : Digital I/O Connector

The pin assignments are as follows :

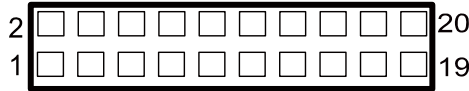

### DIO\_C1

PIN	ASSIGNMENT	PIN	ASSIGNMENT
1	VCC	2	GND
3	VCC	4	GND
5	DIN0	6	DOUT0
7	DIN1	8	DOUT1
9	DIN2	10	DOUT2
11	DIN3	12	DOUT3
13	DIN4	14	DOUT4
15	DIN5	16	DOUT5
17	DIN6	18	DOUT6
19	DIN7	20	DOUT7

## 2-33. MEMORY INSTALLATION

This system is enhanced with 1 DDR DRAM banks, which support up to 2G.

### DRAM BANK CONFIGURATION

DIM 1	TOTAL MEMORY
256M	256MB
512M	512MB
1G	1G
2G	2G

# ***SOFTWARE UTILITIES***

CHAPTER

**3**

This chapter comprises the detailed information of VGA driver, LAN driver, and sound driver, Intel® Chipset Software Installation Utility, touch screen driver, and Flash BIOS update. It also describes how to install the watchdog timer configuration.

Section includes:

- Introduction
- VGA Driver Utility
- Flash BIOS Update
- LAN Driver Utility
- Sound Driver Utility
- Intel® Chipset Software Installation Utility
- Touch Driver Installation Utility
- Watchdog Timer Configuration

### **3-1. INTRODUCTION**

Enclosed with our PPC-7915F/PPC-7917F/PPC-7919F package is our driver utility, which may come in a form of a CD ROM disc or floppy diskettes. For CD ROM disc user, you will only need some of the files contained in the CD ROM disc, please kindly refer to the following chart:

<b>Filename (Assume that CD ROM drive is D:)</b>	<b>Purpose</b>
D:\Driver\VGA	Intel® 945GSE For VGA driver installation
D:\Driver\FLASH	For BIOS update utility
D:\Driver\LAN	Marvell Yukon 88E8071 PCI-E Gigabit Ethernet For LAN Driver installation
D:\Driver\Sound	Realtek ALC888 High Definition Audio For Sound driver installation
D:\Driver\UTILITY	Intel® Chipset Software Installation Utility For Win 2000, XP, Server2003, Vista
D:\Driver\Touch	Touchkit utility For Touch Driver installation
D:\Driver\Wireless	Ralink RT2561t For Wireless Driver installation
D:\Driver\ AHCI	Intel F6 Floppy Utility For XP, Server2003 Vista32

## 3-2. VGA DRIVER UTILITY

The VGA interface embedded with our PPC-7915F/PPC-7917F/PPC-7919F can support a wide range of display. You can display CRT, LVDS simultaneously with the same mode.

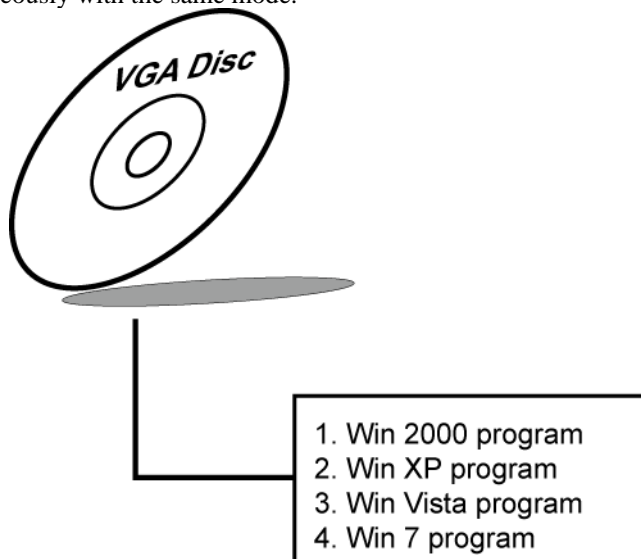

### 3-3-1. Installation of VGA Driver:

To install the VGA Driver, simply follow the following steps:

- (1). Place insert the Utility Disk into Floppy Disk Drive A/B or CD ROM drive.
- (2). Under Windows 2000/XP/Vista/7 system, go to the directory where VGA driver is located.
- (3). Click **Setup.exe** file for VGA driver installation.
- (4). Follow the instructions on the screen to complete the installation.
- (5). Once installation is completed, shut down the system and restart in order for the changes to take effect.

### 3-3. FLASH BIOS UPDATE

#### 3-3-1. Introduction

Users of PPC-7915F/PPC-7917F/PPC-7919F can use the program “Awdflash.exe” contained in the Utility Disk for system BIOS update.

#### 3-3-2. Installation of system BIOS

1. Copy “Awdflash.exe” from Driver Disk to Drive C.
2. Type the path to Awdflash.exe and execute the system BIOS  
AWDFLASH 7915xxxx.bin
3. The screen will display the table below:

FLASH MEMORY WRITER V7.XX (C) Award Software 2001 All Rights Reserved
Flash Type -49LF004B File Name to Program: 7915xxxx.bin
Error Message : Do You Want To Save BIOS (Y/N)

If you want to save up the original BIOS, enter "Y" and press < Enter > .  
If you choose "N", the following table will appear on screen.

FLASH MEMORY WRITER V7.XX (C) Award Software 2001 All Rights Reserved
Flash Type - 49LF004B File Name to Program: 7915xxxx.bin
Error Message : Are You Sure To Program (Y/N)



Select "Y", and the BIOS will be renewed. When you are refreshing the BIOS, do not turn off or reset the system, or you will damage the BIOS. After you have completed all the programming, the screen displays the table below:

FLASH MEMORY WRITER V7.XX (C) Award Software 2001 All Rights Reserved		
Flash Type –49LF004B		
File Name to Program: 7915xxxx.bin		
Verifying Flash Memory – 7FFFF OK		
<input type="checkbox"/> Write OK	<input type="checkbox"/> No Update	<input type="checkbox"/> Write Fail
F1: Reset F10: Exit		

Please reset or power off the system, then the Flash BIOS is fully implemented.

### **3-4. LAN DRIVER UTILITY**

#### **3-4-1. Introduction**

The PPC-7915F/PPC-7917F/PPC-7919F Panel PC is enhanced with LAN function that can support various network adapters. Installation programs for LAN drivers are listed as follows:

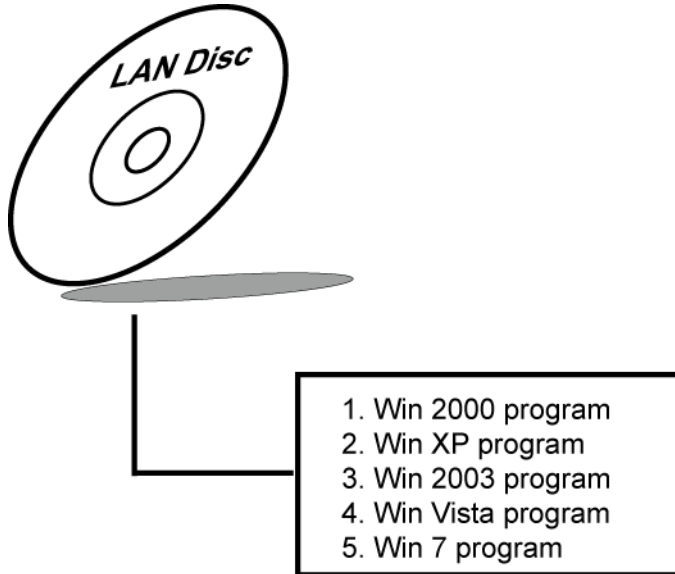

**For more details on Installation procedure, please refer to Readme.txt file found on LAN DRIVER UTILITY.**

## 3-5. SOUND DRIVER UTILITY

### 3-5-1. Introduction

The Realtek ALC888 sound function enhanced in this system is fully compatible with Windows 2000, Windows XP, Windows 2003, Windows Vista, and Windows 7. Below, you will find the content of the Sound driver :

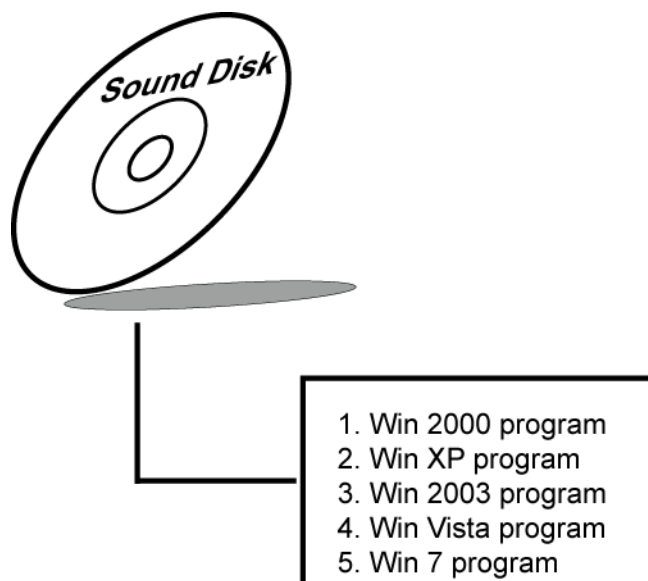

### 3-5-2. Installation Procedure for Windows 2000/XP/2003/Vista/7

1. From the task bar, click on Start, and then Run.
2. In the Run dialog box, type D:\Sound\setup, where "D:\Sound\pathname" refers to the full path to the source files.
3. Click on the OK button or press the ENTER key.
4. Click on the "Next" and OK prompts as they appear.
5. Reboot the system to complete the driver installation.

## **3-6. INTEL® CHIPSET SOFTWARE INSTALLATION UTILITY**

### **3-6-1. Introduction**

The Intel® Chipset Software Installation Utility installs to the target system the Windows\* INF files that outline to the operating system how the chipset components will be configured. This is needed for the proper functioning of the following features:

- Core PCI and ISAPNP Services
- AGP Support
- IDE/ATA33/ATA66/ATA100 Storage Support
- USB Support
- Identification of Intel® Chipset Components in Device Manager

### **3-6-2. Installation of Utility for Windows XP/2003/Vista**

The Utility Pack is to be installed only for Windows XP, 2003, Vista program.

It should be installed right after the OS installation, kindly follow the following steps:

1. Place insert the Utility Disk into Floppy Disk Drive A/B or CD ROM drive.
2. Under Windows XP, 2003, Vista system, go to the directory where Utility Disc is located.
3. Click **Setup.exe** file for utility installation.
4. Follow the instructions on the screen to complete the installation.
5. Once installation is completed, shut down the system and restart in order for the changes to take effect.

## 3-7. TOUCH DRIVER INSTALLATION UTILITY

### 3-7-1. Installation of Utility for Windows2000/XP/2003

The touchscreen driver utility is to be installed only for Windows 2000, Windows XP, Windows 2003, Windows Vista, and Windows 7 program.

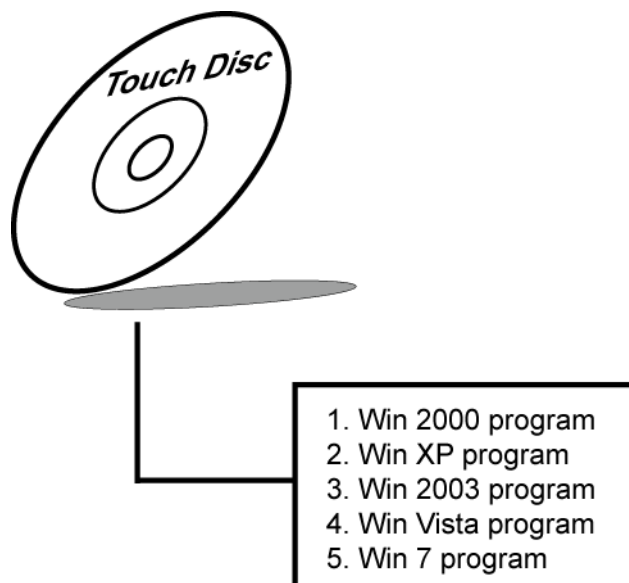

It should be installed right after the OS installation, kindly follow the following steps:

1. Please insert the Utility Disk into Floppy Disk Drive A/B or CD ROM drive.
2. Under Windows 2000/XP/2003/Vista/7 system, go to the directory where Utility Disc is located.
3. Click **Setup.exe** file for utility installation.
4. Follow the instructions on the screen to complete the installation.
5. Once installation is completed, shut down the system and restart it in order to complete the changes.

### 3-8. WATCHDOG TIMER CONFIGURATION

The Watch-dog Timer has a programmable time-out ranging from 1 to 255 minutes with one minute resolution, or 1 to 255 seconds with 1 second resolution. The units of the WDT timeout value are selected via bit[7] of the WDT\_TIMEOUT register, which is located on I/O Port address 0x865h. The WDT time-out value is set through the WDT\_VAL Runtime register, which is located on I/O Port address 0x866h. Setting the WDT\_VAL register to 0x00 disables the WDT function. Setting the WDT\_VAL to any other non-zero value will cause the WDT to reload and begin counting down from the value loaded. Setting the Register located on I/O address 0x867h and 0x868h as 00h to finish timer configuration.

#### Example Program

Example Code:

(1)

```
-----  
; Enable Watch-Dog Timer  
-----  
    mov     dx, (800h+65h)    ; Time counting Unit minute or second  
    mov     al, 80h          ; al = 00h : minute, or al = 80h : second  
    out     dx, al  
    mov     dx, (800h+66h)  
    mov     al, 20           ; al = Watch Dog Timer Second (s) , 20 sec(s)  
    out     dx, al  
    mov     dx, (800h+67h)  
    mov     al, 00h  
    out     dx, al  
    mov     dx, (800h+68h)    ; Start Watch Dog Timer  
    mov     al, 00h  
    out     dx, al
```

(2)

```
-----  
; Disable Watch-Dog Timer  
-----  
    mov     dx, (800h+66h)    ; Disabled Watch Dog  
    mov     al, 00h  
    out     dx, al  
    mov     dx, (800h+67h)  
    mov     al, 00h  
    out     dx, al  
    mov     dx, (800h+68h)    ; Clear Status Bit  
    mov     al, 00h  
    out     dx, al
```

# ***AWARD BIOS SETUP***

CHAPTER

**4**

This chapter shows how to set up the Award BIOS.

Section includes:

- Introduction
- Entering Setup
- The Standard CMOS Features
- The Advanced BIOS Features
- The Advanced Chipset Features
- Integrated Peripherals
- Power Management Setup
- PNP/PCI Configuration
- PC Health Status
- Load Fail-Safe Defaults
- Load Optimized Defaults
- Password Setting
- Save and Exit Setup
- Exit Without Saving

## **4-1. INTRODUCTION**

This chapter will show you the function of the BIOS in managing the features of your system. The PPC-7915F/ PPC-7917F/ PPC-7919F are equipped with the BIOS for system chipset from Phoenix -Award Software Inc. This page briefly explains the function of the BIOS in managing the special features of your system. The following pages describe how to use the BIOS for system chipset Setup menu.

Your application programs (such as word processing, spreadsheets, and games) rely on an operating system such as DOS or OS/2 to manage such things as keyboard, monitor, disk drives, and memory.

The operating system relies on the BIOS (Basic Input and Output system), a program stored on a ROM (Read-only Memory) chip, to initialize and configure your computer's hardware. As the interface between the hardware and the operating system, the BIOS enables you to make basic changes to your system's hardware without having to write a new operating system.

The following diagram illustrates the interlocking relationships between the system hardware, BIOS, operating system, and application program:

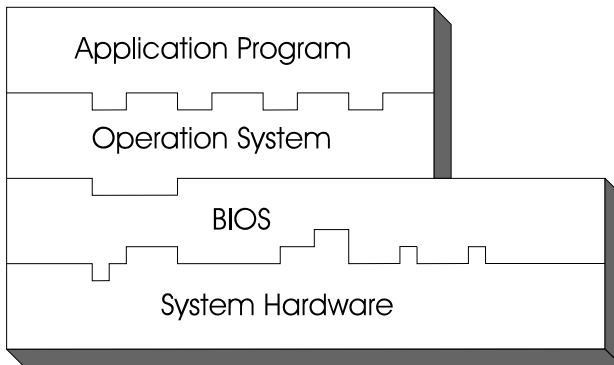



## 4-2. ENTERING SETUP

When the system is powered on, the BIOS will enter the Power-On Self Test (POST) routines and the following message will appear on the lower screen:

**PRESS <DEL> TO ENTER SETUP, ESC TO SKIP MEMORY TEST**

As long as this message is present on the screen you may press the <Del> key (the one that shares the decimal point at the bottom of the number keypad) to access the Setup program. In a moment, the main menu of the Award SETUP program will appear on the screen:

Phoenix - AwardBIOS CMOS Setup Utility	
<ul style="list-style-type: none"> <li>▶ Standard CMOS Features</li> <li>▶ Advanced BIOS Features</li> <li>▶ Advanced Chipset Features</li> <li>▶ Integrated Peripherals</li> <li>▶ Power Management Setup</li> <li>▶ PnP/PCI Configurations</li> <li>▶ PC Health Status</li> </ul>	<ul style="list-style-type: none"> <li>Load Fail-Safe Defaults</li> <li>Load Optimized Defaults</li> <li>Set Supervisor Password</li> <li>Set User Password</li> <li>Save &amp; Exit Setup</li> <li>Exit Without Saving</li> </ul>
Esc : Quit F10 : Save & Exit Setup	↑↓→← : Select Item
Time, Date, Hard Disk Type ....	

### Setup program initial screen

You may use the cursor the up/down keys to highlight the individual menu items. As you highlight each item, a brief description of the highlighted selection will appear at the bottom of the screen.

### 4-3. THE STANDARD CMOS FEATURES

Highlight the "STANDARD CMOS FEATURES" and press the <ENTER> key and the screen will display the following table:

Phoenix - AwardBIOS CMOS Setup Utility  
Standard CMOS Features

Date (mm:dd:yy)	Mon, Jan 1 2007	Item Help
Time (hh:mm:ss)	0 : 6 : 13	
▶ IDE Channel 0 Master	[ None ]	Menu Level ▶  Change the day, month, year and century
▶ IDE Channel 0 Slave	[ None ]	
▶ IDE Channel 2 Master	[ ST9160314AS ]	
▶ IDE Channel 2 Slave	[ CD-224S-R ]	
▶ IDE Channel 3 Master	[ None ]	
▶ IDE Channel 3 Slave	[ None ]	
Video	[ EGA/VGA ]	
Halt On	[ All, But Keyboard ]	
Base Memory	640K	
Extended Memory	1038336K	
Total Memory	1039360K	
↑↓→←: Move Enter: Select +/-/PU/PD:Value F10:Save ESC:Exit F1:General Help F5: Previous Values F6: Fail-Safe Defaults F7:Optimized Defaults		

CMOS Setup screen

In the above Setup Menu, use the arrow keys to highlight the item and then use the <PgUp> or <PgDn> keys to select the value you want in each item.

**DATE:**

< Month >, < Date > and <Year >. Ranges for each value are in the CMOS Setup Screen, and the week-day will skip automatically.

**TIME:**

< Hour >, < Minute >, and < Second >. Use 24 hour clock format, i.e., for PM numbers, add 12 to the hour. For example: 4: 30 P.M. You should enter the time as 16:30:00.

**IDE CHANNEL 0/2/3 Master:**

**IDE CHANNEL 0/2/3 Slave:**

The BIOS can automatically detect the specifications and optimal operating mode of almost all SATA hard drives. When you select type AUTO for a hard drive, the BIOS detect its specifications during POST, every time system boots.

If you do not want to select drive type AUTO, other methods of selecting drive type are available:

1. Match the specifications of your installed SATA hard drive(s) with the preprogrammed values for hard drive types 1 through 45.
2. Select USER and enter values into each drive parameter field.
3. Use the SATA HDD AUTO DETECTION function in Setup.

Here is a brief explanation of drive specifications:

Type: The BIOS contains a table of pre-defined drive types. Each defined drive type has a specified number of cylinders, number of heads, write precompensation factor, landing zone, and number of sectors. Drives whose specifications do not accommodate any predefine type are classified as type USER.

- Size: Disk drive capacity (approximate). Note that this size is usually greater than the size of a formatted disk given by a disk-checking program.
- Cyls: number of cylinders.
- Head: number of heads.
- Precomp: write precompensation cylinders.
- Landz: landing zone.
- Sector: number of sectors.
- Mode: Auto, Normal, Large or LBA.

Auto: The BIOS automatically determines the optimal mode.

- Normal: Maximum number of cylinders, heads, sectors supported are 1024, 16 and 63.
- Large: For drives that do not support LBA and have more

than 1024 cylinders.

- LBA (Logical Block Addressing): During drive accesses, the SATA controller transforms the data address described by sector, head and cylinder number into a physical block address, significantly improving data transfer rates. For drives greater than 1024 cylinders.

**VIDEO:**

This category selects the type of video adapter used for the primary system monitor. Although secondary monitors are supported, you do not have to select the type in Setup. Available Options are as follows:

EGA/VGA	Enhanced Graphics Adapter/Video Graphics Array. For EGA, VGA, SEGA, SVGA or PGA monitor adapters.
CGA 40	Color Graphics Adapter, power up in 40 column mode.
CGA 80	Color Graphics Adapter, power up in 80 column mode.
MONO	Monochrome adapter, includes high resolution monochrome adapters.

**HALT ON:**

This category allows user to choose whether the computer will stop if an error is detected during power up. Available options are “All errors”, “No errors”, “All, But keyboard”, “All, But Diskette”, and “All But Disk/Key”.

**BASE MEMORY:**

Displays the amount of conventional memory detected during boot up.

**EXTENDED MEMORY:**

Displays the amount of extended memory detected during boot up.

**TOTAL MEMORY:**

Displays the total memory available in the system.

**HARD DISK ATTRIBUTES:**

Type	Cylinders	Heads	V-P comp	LZone	Sect	Capacity
1	306	4	128	305	17	10
2	615	4	300	615	17	20
3	615	6	300	615	17	30
4	940	8	512	940	17	62
5	940	6	512	940	17	46
6	615	4	65535	615	17	20
7	642	8	256	511	17	30
8	733	5	65535	733	17	30
9	900	15	65535	901	17	112
10	820	3	65535	820	17	20
11	855	5	65535	855	17	35
12	855	7	65535	855	17	49
13	306	8	128	319	17	20
14	733	7	65535	733	17	42
15	000	0	0000	000	00	00
16	612	4	0000	663	17	20
17	977	5	300	977	17	40
18	977	7	65535	977	17	56
19	1024	7	512	1023	17	59
20	733	5	300	732	17	30
21	733	7	300	732	17	42
22	733	5	300	733	17	30
23	306	4	0000	336	17	10
24	977	5	65535	976	17	40
25	1024	9	65535	1023	17	76
26	1224	7	65535	1223	17	71
27	1224	11	65535	1223	17	111
28	1224	15	65535	1223	17	152
29	1024	8	65535	1023	17	68
30	1024	11	65535	1023	17	93
31	918	11	65535	1023	17	83
32	925	9	65535	926	17	69
33	1024	10	65535	1023	17	85
34	1024	12	65535	1023	17	102
35	1024	13	65535	1023	17	110
36	1024	14	65535	1023	17	119
37	1024	2	65535	1023	17	17
38	1024	16	65535	1023	17	136
39	918	15	65535	1023	17	114
40	820	6	65535	820	17	40
41	1024	5	65535	1023	17	42
42	1024	5	65535	1023	26	65
43	809	6	65535	852	17	40
44	809	6	65535	852	26	61
45	776	8	65335	775	33	100
47			AUTO			

**Award Hard Disk Type Table**

### 4-4. THE ADVANCED BIOS FEATURES

Choose the “ADVANCED BIOS FEATURES” in the main menu, the screen shown as below.

Phoenix - AwardBIOS CMOS Setup Utility  
Advanced BIOS Features

▶ CPU Feature	[Press Enter]	Item Help
▶ Hard Disk Boot Priority	[Press Enter]	
▶ CD-ROM Boot Priority	[Press Enter]	Menu Level ▶
CPU L1 & L2 Cache	[Enabled]	
Hyper-Threading Technology	[Enabled]	
Quick Power On Self Test	[Enabled]	
First Boot Device	[Hard Disk]	
Second Boot Device	[CDROM]	
Third Boot Device	[LAN]	
Boot Other Device	[Enabled]	
Boot Up NumLock Status	[On]	
Gate A20 Option	[Normal]	
Typematic Rate Setting	[Disabled]	
x Typematic Rate (Chars/Sec)	6	
x Typematic Delay (Msec)	250	
Security Option	[Setup]	
x APIC Mode	Enabled	
MPS Version Control For OS	[1.1]	
↑↓→←: Move Enter: Select +/-/PU/PD:Value F10:Save ESC:Exit F1:General Help F5: Previous Values F6: Fail-Safe Defaults F7:Optimized Defaults		

#### BIOS Features Setup Screen

The “BIOS FEATURES SETUP” allow you to configure your system for basic operation. The user can select the system’s boot-up sequence and security.

A brief introduction of each setting is given below.

**CPU FEATURE:**

The options for these items are found in its sub menu. By pressing the <ENTER> key, you are prompt to enter the sub menu of the detailed options as shown below:

Phoenix – Award CMOS Setup Utility  
CPU Feature

Delay Prior to Thermal	[16 Min]	Item Help
Limit CPUID MaxVal	[Disabled]	Menu Level ►
C1E Function	[Disabled]	
Execute Disable Bit	[Enabled]	
↑↓→←:Move Enter: Select +/-/PU/PD:Value F10:Save ESC:Exit F1:General Help F5: Previous Values F6:Fail-Safe Defaults F7:Optimized Defaults		

Descriptions on each item above are as follows:

**1. DELAY PRIOR TO THERMAL:**

The Delay Prior To Thermal BIOS feature controls the activation of the Thermal Monitor's automatic mode. It allows you to determine when the Pentium-M's Thermal Monitor should be activated in automatic mode after the system boots.

**2. LIMIT CPUID MAXVAL:**

The CPUID instruction of some CPUs will return a value greater than 3.If you are using Windows operating system. Please disable this feature.

**3. C1E FUNCTION:**

This is enabled to reduce power during idle operation.

**4. EXECUTE DISABLE BIT:**

To select enable or disable the No-Execution Page Protection Technology.

**HARD DISK BOOT PRIORITY:**

The options for these items are found in its sub menu. By pressing the <ENTER> key, you are prompt to enter the sub menu of the detailed options as shown below:

Phoenix – Award CMOS Setup Utility  
Hard Disk Boot Priority

1. Ch2 M. : ST9160314AS 2. Bootable Add-in Cards	Item Help  Menu Level ► Use<↑> or <↓> to select a device, then press <+> to move it up, or <-> to move it down the list. Press <ESC> to exit this menu.
↑↓→←:Move Enter: Select +/-/PU/PD:Value F10:Save ESC:Exit F1:General Help F5: Previous Values F6:Fail-Safe Defaults F7:Optimized Defaults	

Select Hard Disk Boot Device Priority



**CD-ROM BOOT PRIORITY:**

The options for these items are found in its sub menu. By pressing the <ENTER> key, you are prompt to enter the sub menu of the detailed options as shown below:

Phoenix – Award CMOS Setup Utility  
CD-ROM Boot Priority

1. Ch2 S. : CD-224S-R	Item Help
↑↓→←:Move Enter: Select +/-/PU/PD:Value F10:Save ESC:Exit F1:General Help F5: Previous Values F6:Fail-Safe Defaults F7:Optimized Defaults	Menu Level ► Use<↑> or <↓> to select a device, then press <+> to move it up, or <-> to move it down the list. Press <ESC> to exit this menu.

Select CD-ROM Boot Priority

**CPU L1 & L2 CACHE:**

This item allows you to enable or disable CPU internal Cache.

**HYPER-THREADING TECHNOLOGY:**

This item allows you to enable or disable CPU Hyper-Threading Technology function.

**QUICK POWER ON SELF TEST:**

This item allows you to speed up Power On Self Test (POST) after power-up the computer. When enabled, the BIOS will shorten or skip some check items during POST.

**FIRST/SECOND/ THIRD/ OTHER BOOT DEVICE:**

The BIOS attempt to load the operating system from the devices in the sequence selected in these items.

**BOOT UP NUMLOCK STATUS:**

Select power on state for NumLock.

**GATE 20A OPTION:**

This entry allows you to select how the gate A20 is handled. When Normal was set, a pin in the keyboard controller controls Gate A20. And when Fast was set, the chipset controls Gate A20.

**TYPEMATIC RATE SETTING:**

Enable this item if you wish to be able to configure the characteristics of your keyboard. Typematic refers to the way in which characters are entered repeatedly if a key is held down. For example, if you press and hold down the "A" key, the letter "a" will repeatedly appear on your screen on your screen until you release the key. When enabled, the typematic rate and typematic delay can be selected.

**TYPEMATIC RATE (CHARS/SEC):**

This item sets the number of times a second to repeat a key stroke when you hold the key down.

**TYPEMATIC DELAY (MSEC):**

The item sets the delay time after the key is held down before it begins to repeat the keystroke.

**SECURITY OPTION:**

This category allows you to limit access to the system and Setup, or just to Setup.

System	The system will not boot and access to Setup will be denied if the correct password is not entered at the prompt.
Setup	The system will boot, but access to Setup will be denied if the correct password is not entered at the prompt.

 To disable security, select PASSWORD SETTING at Main Menu and then you will be asked to enter password. Do not type anything and just press <Enter>, it will disable security. Once the security is disabled, the system will boot and you can enter Setup freely.

**APIC MODE:**

To Enable Advanced Programmable Interrupt Controller

**MPS VERSION CONTROL FOR OS:**

This option is only valid for multiprocessor motherboards as it specifies the version of the Multiprocessor Specification (MPS) that the motherboard will use. The MPS is a specification by which PC manufacturers design and build Intel architecture systems with two or more processors.

**4-5. ADVANCED CHIPSET FEATURES**

Choose the "ADVANCED CHIPSET FEATURES" from the main menu, the screen shown as below.

Phoenix - AwardBIOS CMOS Setup Utility  
Advanced Chipset Features

DRAM Timing Selectable	[By SPD]	Item Help
X CAS Latency Time	Auto	Menu Level ►
X DRAM RAS# to CAS# Delay	Auto	
X DRAM RAS# Precharge	Auto	
X Precharge dealy (tRAS)	Auto	
X System Memory Frequency	Auto	
System BIOS Cacheable	[Enabled]	
Video BIOS Cacheale	[Disabled]	
** VGA Setting **		
On-Chip Frame Buffer Size	[8MB]	
DVMT Mode	[DVMT]	
DVMT/ FIXED Memory Size	[128 MB]	
Boot Display	[CRT+LFP1]	
↑↓→←: Move Enter: Select +/-/PU/PD:Value F10:Save ESC:Exit F1:General Help F5: Previous Values F6: Fail-Safe Defaults F7:Optimized Defaults		

**Chipset Features Setup Screen**

This parameter allows you to configure the system based on the specific features of the installed chipset. The chipset manages bus speed and access to system memory resources, such as DRAM and the external cache.

It also coordinates communications between conventional ISA bus and the PCI bus. It must be stated that these items should never need to be altered. The default settings have been chosen because they provide the best operating conditions for the system. The only time you might consider making any changes would be if you discovered that data was being lost while using your system.

**DRAM TIMEING SELECTABLE:**

The value in this field depends on performance parameters of the installed memory chips (DRAM). Do not change the value from the factory setting unless you install new memory that has a different performance rating than the original DRAMs.

**CAS LATENCY TIME:**

When synchronous DRAM is installed, the number of clock cycles of CAS latency depends on the DRAM timing.

**DRAM RAS# TO CAS# DELAY:**

This item let you insert a timing delay between the CAS and RAS strobe signals, used when DRAM is written to, read from, or refreshed. Fast gives faster performance; and Slow gives more stable performance. This field applies only when synchronous DRAM is installed in the system. The choices are 2 and 3.

**DRAM RAS# PRECHARGE TIME:**

If an insufficient number of cycles is allowed for the RAS to accumulate its charge before DRAM refresh, the refresh may be incomplete and the DRAM may fail to retain data. Fast gives faster performance; and Slow gives more stable performance. This field applies only when synchronous DRAM is installed in the system. The choices are 2 & 3.

**PRECHARGE DEALY (tRAS):**

Precharge Delay This setting controls the precharge delay, which determines the timing delay for DRAM precharge

**SYSTEM MEMORY FREQUENCY:**

Allow to choose different frequency of memory module.

**SYSTEM BIOS CACHEABLE:**

This item allows you to enable caching of the system BIOS ROM at F0000h-FFFFFh, resulting in better system performance. However, if any program writes to this memory area, a system error may result.

**VIDEO BIOS CACHEABLE:**

This item allows you to enable caching of the video BIOS, resulting in better system performance. However, if any program writes to this memory area, a system error may result.

**ON-CHIP FRAME BUFFER SIZE:**

The On-Chip Frame Buffer Size can be set as 8MB. This memory is shared with the system memory.

**DVMT MODE:**

Intel Dynamic Video Memory Technology Mode.

**DVMT/FIXED MEMORY SIZE:**

DVMT Memory Size Select.

**BOOT DISPLAY:**

To select the boot-up display type.

### 4-6. INTEGRATED PERIPHERALS

Choose "INTEGRATED PERIPHERALS" from the main setup menu, a display will be shown on screen as below:

Phoenix - AwardBIOS CMOS Setup Utility  
Integrated Peripherals

▶ OnChip IDE Device	[Press Enter]	Item Help
▶ Onboard Device	[Press Enter]	
▶ SuperIO Device	[Press Enter]	Menu Level ▶
Onboard Serial Port 3	[3E8/IRQ10]	
Onboard Serial Port 4	[2E8/IRQ11]	
Watch Dog Timer Select	[Disabled]	
▶ USB Device Setting	[Press Enter]	
↑↓→←: Move Enter: Select +/-/PU/PD:Value F10:Save ESC:Exit F1:General Help F5: Previous Values F6: Fail-Safe Defaults F7:Optimized Defaults		

#### Integrated Peripherals Setup Screen

By moving the cursor to the desired selection and by pressing the <F1> key, the all options for the desired selection will be displayed for choice.

- 🔔 If bios setup menu item supports USB device boot, it will cause Win9x detects the same storages twice when the system is rebooted, and USB HDD will fail. Note: this cause just happen under Win9x, the phenomenon is a limitation.

**ONCHIP IDE DEVICE:**

The options for these items are found in its sub menu. By pressing the <ENTER> key, you are prompt to enter the sub menu of the detailed options as shown below:

Phoenix – Award CMOS Setup Utility  
OnChip IDE Device

IDE HDD Block Mode	[Enabled]	Item Help
IDE DMA transfer access	[Enabled]	
On-Chip Primary PCI IDE	[Enabled]	Menu Level ►  If your IDE hard drive supports block mode select Enabled for automatic detection of the optional number of block read/writes per sector the drive can support.
IDE Primary Master PIO	[Auto]	
IDE Primary Slave PIO	[Auto]	
IDE Primary Master UDMA	[Auto]	
IDE Primary Slave UDMA	[Auto]	
On-Chip Secondary PCI IDE	[Enabled]	
IDE Secondary Master PIO	[Auto]	
IDE Secondary Slave PIO	[Auto]	
IDE Secondary Master UDMA	[Auto]	
IDE Secondary Slave UDMA	[Auto]	
*** On-Chip Serial ATA Setting ***		
SATA Mode	[IDE]	
On-Chip Serial ATA	[Enhanced Mode]	
X PATA IDE Mode	Secondary	
SATA Port	P0, P2 is Primary	
↑↓→←:Move Enter: Select +/-/PU/PD:Value F10:Save ESC:Exit F1:General Help F5: Previous Values F6:Fail-Safe Defaults F7:Optimized Defaults		

Descriptions on each item above are as follows:

**1. IDE HDD BLOCK MODE:**

Block mode is also called block transfer, multiple commands, or multiple sector read/write. If your IDE hard drive supports block mode (most new drives do), select Enabled for automatic detection of the optimal number of block read/writes per sector the drive can support.

**2. IDE DMA TRANSTER ACCESS:**

To Enable/Disable the IDE DMA transfer access.

**3. ON-CHIP PRIMARY/SECONDARY PCI IDE:**

The integrated peripheral controller contains an IDE interface with support for two IDE channels. Select Enabled to activate each channel separately.

**4. PRIMARY MASTER/SLAVE PIO:**

**SECONDARY MASTER/SLAVE PIO:**

The four IDE PIO fields allow you to set a PIO mode (0-4) for each of the four IDE devices that the onboard IDE interface supports. Modes 0 through 4 provide successively increased performance. In Auto mode, the system automatically determines the best mode for each device.

**5. PRIMARY MASTER/SLAVE UDMA:**

**SECONDARY MASTER/SLAVE UDMA:**

Ultra DMA/33 implementation is possible only if your IDE hard drive supports it and the operating environment includes a DMA driver (Windows 95 OSR2 or a third-party IDE bus master driver). If you hard drive and your system software both support Ultra DMA/33, select Auto to enable BIOS support.

**6. SATA MODE:**

Set the Serial ATA configuration. When set in Advanced Host Controller Interface (AHCI), the SATA controller is set to Native mode. Configuration options: [IDE] [AHCI]

**7. ON-CHIP SERIAL ATA:**

[Disabled]: Disabled SATA Controller.

[Enhanced Mode]: Enable both SATA and PATA. Max.of 6 IDE drives are supported.

[SATA Only]: SATA is operating in legacy mode.

**8. PATA IDE MODE:**

To select PATA IDE Mode sequence.

**9. SATA PORT:**

According PATA IDE Mode to determine SATA sequence.



**ONBOARD DEVICE:**

The options for these items are found in its sub menu. By pressing the <ENTER> key, you are prompt to enter the sub menu of the detailed options as shown below:

Phoenix – Award CMOS Setup Utility  
Onboard Device

Audio Function	[Auto]	Item Help
		Menu Level ►
↑↓→←:Move Enter: Select +/-/PU/PD:Value F10:Save ESC:Exit F1:General Help F5: Previous Values F6:Fail-Safe Defaults F7:Optimized Defaults		

Descriptions on each item above are as follows:

**1. AUDIO FUNCTION:**

This item allows you to enable or disable onboard Audio function.

**SUPER IO DEVICE:**

The options for these items are found in its sub menu. By pressing the <ENTER> key, you are prompt to enter the sub menu of the detailed options as shown below:

Phoenix – Award CMOS Setup Utility  
SuperIO Device

Onboard Serial Port 1	[3F8/IRQ4]	Item Help
Onboard Serial Port 2	[2F8/IRQ3]	Menu Level ►
Onboard Parallel Port	[378/IRQ7]	
Parallel Port Mode	[Standard]	
X EPP Mode Select	3	
↑↓→←: Move    Enter: Select    +/-/PU/PD: Value    F10: Save    ESC: Exit    F1: General Help F5: Previous Values    F6: Fail-Safe Defaults    F7: Optimized Defaults		

Descriptions on each item above are as follows:

- 1. ONBOARD SERIAL PORT 1/2:**  
Select an address and corresponding interrupt for the first and second serial ports.
- 2. ONBOARD PARALLEL PORT**  
This item allows you to determine access onboard parallel port controller with which I/O address.
- 3. PARALLEL PORT MODE**  
Select an operating mode for the onboard parallel (printer) port. Select *Normal*, *Compatible*, or *SPP* unless you are certain your hardware and software both support one of the other available modes.
- 4. ECP MODE USE DMA**  
Select a DMA channel for the parallel port for use during ECP mode.

**ONBOARD SERIAL PORT 3/4:**

Select an address and corresponding interrupt for the third and fourth serial ports

**WATCH DOG TIMER SELECT:**

To select watch-dog times.

**USB DEVICE SETTING:**

The options for these items are found in its sub menu. By pressing the <ENTER> key, you are prompt to enter the sub menu of the detailed options as shown below:

Phoenix – Award CMOS Setup Utility  
USB Device Setting

USB 1.0 Controller	[Enabled]	Item Help
USB 2.0 Controller	[Enabled]	Menu Level ►
USB Operation Mode	[High Speed]	
USB Keyboard Function	[Enabled]	
USB Mouse Function	[Enabled]	
USB Storage Function	[Enabled]	
*** USB Mass Storage Device Boot Setting ***		
↑↓→←:Move Enter: Select +/-/PU/PD:Value F10:Save ESC:Exit F1:General Help F5: Previous Values F6:Fail-Safe Defaults F7:Optimized Defaults		

Descriptions on each item above are as follows:

**1. USB 1.0 CONTROLLER:**

This should be enabled if your system has a USB installed on the system board and you want to use it. Even when so equipped, if you add a higher performance controller, you will need to disable this feature.

**2. USB 2.0 CONTROLLER:**

Enable the USB 2.0 controller.

**3. USB OPERATION MODE:**

This item allows the user to decide USB device operation mode.

**4. USB KEYBOARD FUNCTION:**

Select Enabled if your system contains a Universal Serial Bus (USB) controller and you have a USB keyboard.

**5. USB MOUSE FUNCTION:**

Select Enabled if your system contains a Universal Serial Bus (USB) controller and you have a USB Mouse.

**6. USB STORAGE FUNCTION:**

Enable the USB Storage Function

**4-7. POWER MANAGEMENT SETUP**

Choose "POWER MANAGEMENT SETUP" option on the main menu, a display will be shown on screen as below :

Phoenix - AwardBIOS CMOS Setup Utility  
Power Management Setup

ACPI Function [Enabled] ACPI Suspend Type [S1(POS)] MODEM Use IRQ [3] Soft-Off by PWR-BTTN [Instand-Off] PWRON After PWR-Fail [On] Power On By Ring [Enabled] Resume by Alarm [Disabled] X Date (of Month) Alarm 0 X Time (hh:mm:ss) Alarm 0 : 0: 0	Item Help <hr/> Menu Level ►
↑↓→←: Move Enter: Select +/-/PU/PD:Value F10:Save ESC:Exit F1:General Help F5: Previous Values F6: Fail-Safe Defaults F7:Optimized Defaults	

**Power Management Setup Screen**

The "Power Management Setup" allows the user to configure the system to the most effectively save energy while operating in a manner consistent with your own style of computer use.

**ACPI FUNCTION:**

Users are allowed to enable or disable the Advanced Configuration and Power Management (ACPI).

**ACPI SUSPEND TYPE:**

This item allows the user to decide ACPI suspend mode

**MODEM USE IRQ:**

This item enable you to name the interrupt request (IRQ) line assigned to the modem (if any) on your system. Activity of the selected IRQ always awakens the system

**SOFT-OFF BY PWR-BTTN:**

Pressing the power button for more than 4 seconds forces the system to enter the Soft-Off state when the system has “hung”. The choices are Delay 4 Sec and Instant-Off.

**PWRON AFTER PWR-FAIL:**

This item allows you to select if you want to power on the system after power failure. The choice: Off and On.

**POWER ON BY RING:**

This category enables or disables the powering up of the system when the modem receives a call while the computer is in Soft-Off state.

**RESUME BY ALARM:**

When enabled, you can set the date and time at which the RTC alarm awakens the system from Suspend mode.

## 4-8. PNP/PCI CONFIGURATION

Choose "PNP/PCI CONFIGURATION" from the main menu, a display will be shown on screen as below:

Phoenix - AwardBIOS CMOS Setup Utility  
PnP/PCI Configurations

Reset Configuration Data	[Disabled]	Item Help
Resources Controlled By X IRQ Resources	[Auto (ESCD)] Press Enter	Menu Level ►  Default is Disabled. Select Enabled to reset Extended System Configuration Data (ESCD) when you exit Setup if you have installed a new add-on and the system reconfiguration has caused such a serious conflict that the OS cannot boot
↑↓→←: Move    Enter: Select    +/-/PU/PD: Value    F10: Save    ESC: Exit    F1: General Help F5: Previous Values    F6: Fail-Safe Defaults    F7: Optimized Defaults		

### PNP/PCI Configuration Setup Screen

The PNP/PCI Configuration Setup describes how to configure PCI bus system. PCI, also known as Personal Computer Interconnect, is a system, which allows I/O devices to operate at speeds nearing the speed of the CPU itself uses when communicating with its own special components.

This section covers technical items, which is strongly recommended for experienced users only.

#### RESET CONFIGURATION DATA:

Normally, you leave this field Disabled. Select Enabled to reset Extended System Configuration Data (ESCD) when you exit Setup if you have

installed a new add-on and the system configuration has caused such a serious conflict that the operating system cannot boot.

**RESOURCE CONTROLLED BY:**

The Award Plug and Play Bios can automatically configure all of the booth and Plug and Play-compatible devices. However, this capability means absolutely nothing unless you are using a Plug and Play operating system such as Windows 95. By choosing “manual”, you are allowed to configure the *IRQ Resources and DMA Resources*.

**IRQ RESOURCES:**

The options for these items are found in its sub menu. By pressing the <ENTER> key, you are prompt to enter the sub menu of the detailed options as shown below:

Phoenix – Award CMOS Setup Utility  
IRQ Resources

	Item Help
IRQ-3 assigned to [PCI Device]	Menu Level ►  Legacy ISA for devices compliant with the original PC AT bus specification, PCI/ISA PnP for devices compliant with the Plug and Play standard whether designed for PCI or ISA bus architecture
IRQ-4 assigned to [PCI Device]	
IRQ-5 assigned to [PCI Device]	
IRQ-7 assigned to [PCI Device]	
IRQ-9 assigned to [PCI Device]	
IRQ-10 assigned to [PCI Device]	
IRQ-11 assigned to [PCI Device]	
IRQ-12 assigned to [PCI Device]	
IRQ-14 assigned to [PCI Device]	
IRQ-15 assigned to [PCI Device]	
↑↓→←: Move    Enter: Select    +/-/PU/PD: Value    F10: Save    ESC: Exit    F1: General Help F5: Previous Values    F6: Fail-Safe Defaults    F7: Optimized Defaults	

Descriptions on each item above are as follows:

**1. IRQ-n Assigned to:**

You may assign each system interrupt a type, depending on the type of device using the interrupt.

### 4-9. PC HEALTH STATUS

Choose "PC HEALTH STATUS" from the main menu, a display will be shown on screen as below:

Phoenix - AwardBIOS CMOS Setup Utility  
PC Health Status

Shutdown Temperature	[Disabled]	Item Help
Current CPU Temperature	28°C	
Vcore	0.88V	Menu Level ▶
5V	4.91V	
12V	12.48V	
CPU Fan1 Speed	3274 RPM	
Fan1 Speed	0 RPM	
↑↓→←: Move Enter: Select +/-/PU/PD:Value F10:Save ESC:Exit F1:General Help F5: Previous Values F6: Fail-Safe Defaults F7:Optimized Defaults		

#### PC Health Status Setup Screen

The PC Health Status Setup allows you to select whether to choose between monitoring or to ignore the hardware monitoring function of your system.

#### SHUTDOWN TEMPERATURE:

This item allows you to set up the CPU Warning Temperature.

#### CURRENT CPU TEMPERATURE:

This item shows you the current CPU temperature.

#### VCORE:

This item shows you the current system voltage.

#### 5V /12V:

Show you the voltage of 5V/12V.

#### CPU FAN1 / FAN1 SPEED:

This item shows you the CPU Fan1/FAN1 speed.



## **4-10. LOAD FAIL-SAFE DEFAULTS**

By pressing the <ENTER> key on this item, you get a confirmation dialog box with a message similar to the following:

Load Fail-Safe Defaults ( Y/N ) ? N

To use the BIOS default values, change the prompt to "Y" and press the <Enter > key. CMOS is loaded automatically when you power up the system.

## **4-11. LOAD OPTIMIZED DEFAULTS**

When you press <Enter> on this category, you get a confirmation dialog box with a message similar to the following:

Load Optimized Defaults ( Y/N ) ? N

Pressing "Y" loads the default values that are factory setting for optimal performance system operations.

## **4-12. PASSWORD SETTING**

User is allowed to set either supervisor or user password, or both of them. The difference is that the supervisor password can enter and change the options of the setup menus while the user password can enter only but do not have the authority to change the options of the setup menus.

### **TO SET A PASSWORD**

When you select this function, the following message will appear at the center of the screen to assist you in creating a password.

Enter Password:

Type the password up to eight characters in length, and press < Enter >. The password typed now will clear any previously entered password from CMOS memory. You will be asked to confirm the password. Type the password again and press the < Enter > key. You may also press < Esc > to abort the selection and not enter a password.

 User should bear in mind that when a password is set, you will be asked to enter the password everything you enter CMOS setup Menu.

### **TO DISABLE THE PASSWORD**

To disable the password, select this function (do not enter any key when you are prompt to enter a password), and press the <Enter> key and a message will appear at the center of the screen:

PASSWORD DISABLED!!!  
Press any key to continue...

Press the < Enter > key again and the password will be disabled. Once the password is disabled, you can enter Setup freely.

### 4-13. SAVE & EXIT SETUP

After you have completed adjusting all the settings as required, you must remember to save these setting into the CMOS RAM. To save the settings, select “SAVE & EXIT SETUP” and press <Enter>, a display will be shown as follows:

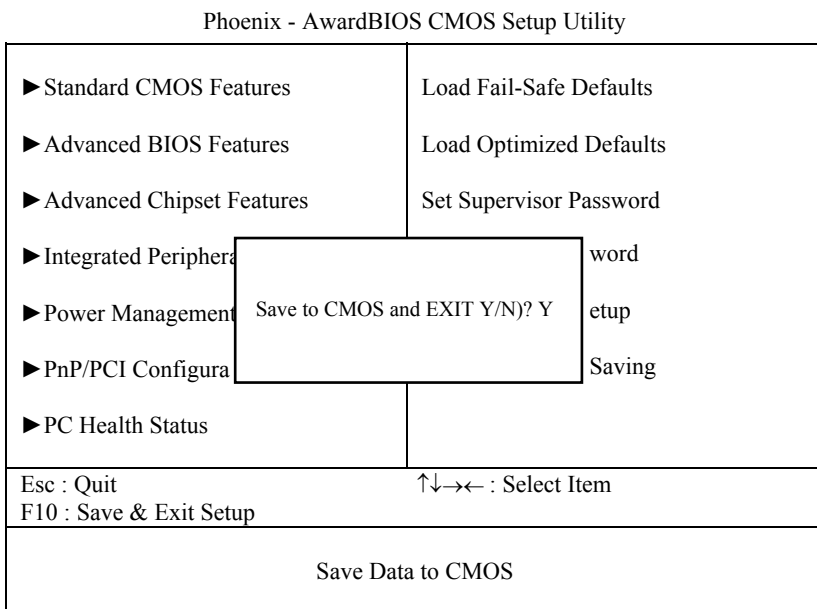

When you confirm that you wish to save the settings, your system will be automatically restarted and the changes you have made will be implemented. You may always call up the setup program at any time to adjust any of the individual items by pressing the <Del> key during boot up.

### 4-14. EXIT WITHOUT SAVING

If you wish to cancel any changes you have made, you may select the "EXIT WITHOUT SAVING" and the original setting stored in the CMOS will be retained. The screen will be shown as below:

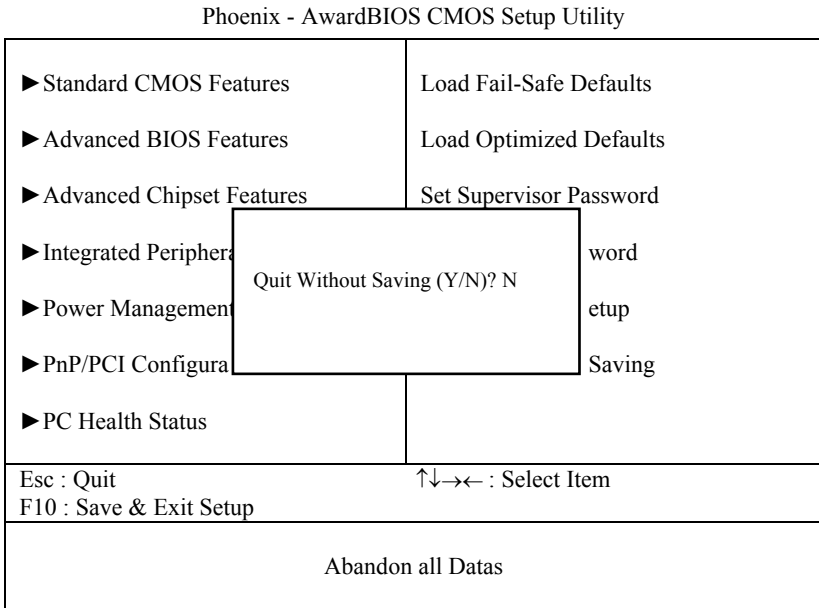

# ***SYSTEM ASSEMBLY***

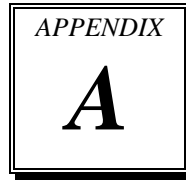

This appendix contain exploded diagram of the system.

Section includes:

- Exploded Diagram for PPC-7915F Whole System
- Exploded Diagram for PPC-7915F Packing
- Exploded Diagram for PPC-7915F Wall Mounting
- Exploded Diagram for PPC-7917F LCD Panel
- Exploded Diagram for PPC-7917F Packing
- Exploded Diagram for PPC-7917F Wall Mounting
- Exploded Diagram for PPC-7919F LCD Panel
- Exploded Diagram for PPC-7919F Packing
- Exploded Diagram for PPC-7919F Wall Mounting

## EXPLODED DIAGRAM FOR PPC-7915F WHOLE SYSTEM

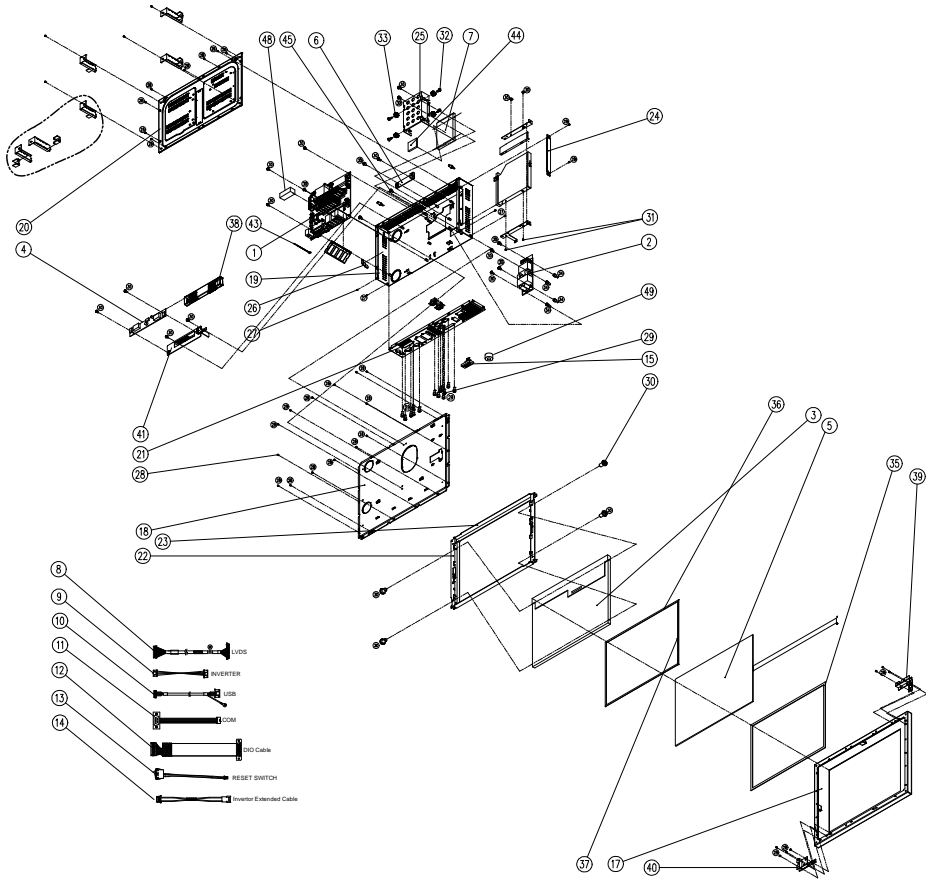

Item	Part No.	QTY	Description
1	PROX-B587LF-G1A	1	Mainboard
2	52-001-09090705	1	Power board
3	52-351-03150102	1	15" LCD
4	52-101-15020003	1	Inverter
5	52-351-00555514	1	15" ELO Touch
6	52-370-01500004	1	Touch control board
7	52-451-40080103	1	160G HDD
8	27-020-17105111	1	LVDS cable
9	27-015-16803071	1	Inverter cable
10	27-016-16808111	1	USB touch control board cable
11	27-024-17106031	3	Com port cable
12	27-062-17105031	1	DIO cable
13	27-019-17105071	1	Power switch cable
14	27-043-16807071	2	Inverter extension cable
15	27-012-17102071	1	Inside connector cable
17	20-004-07001168	1	PPC-7615 Front cover
18	20-029-03061162	1	PPC-7615 LCD Holder
19	20-032-03061171	1	PPC-7915 PC Base
20	20-004-03061171	1	PPC-7915 Rear Cover
21	20-006-03001171	1	PPC-7915 IO Bracket 587
22	20-029-07001168	2	PPC-7615 Panel Side Holder
23	20-006-07001168	2	PPC-7615 Press Touch Connector
24	20-047-03061168	1	PPC-7615 CD-ROM Door
25	20-029-03003168	1	PPC-7615 HDD Holder
27	22-222-30004011	4	Flat Head Screw
28	22-215-30006111	71	Flat Head Screw
29	22-692-40048051	12	CU_BOSS Pillar
30	22-230-30005811	30	Screw
31	22-272-20002011	4	Screw
32	22-272-30128018	8	Screw for HDD cushion M3
33	30-013-01100031	4	Rubber
34	22-290-30009051	4	HEX CU Boss Pillar
35	30-013-15100168	1	PPC-7615 EVA LCD
36	30-013-24100168	2	PPC-7615 PORON LCD Side 1
37	30-013-24200168	2	PPC-7615 PORON LCD Side 2
38	30-056-39100168	1	PPC-7615 Mylar Inerter 15
39	20-006-03001168	1	PPC-7615 FIX XY Direction Touch of Resist For ELO Right
40	20-006-03002168	1	PPC-7615 FIX XY Direction Touch of Resist For ELO Left
41	20-029-03004168	1	PPC-7615 Inverter Holder
43	30-015-04200000	4	Cable Tie
44	21-006-04545001	2	PS-8590 Thermal Pads
45	22-232-40004011	2	Round Head Screw
46	27-012-17111071	1	Power + SATA cable
47	34-017-01604000	1	BIOS Label
48	30-050-31100171	1	Foam
49		1	Magnet core

## EXPLODED DIAGRAM FOR PPC-7915F PACKING

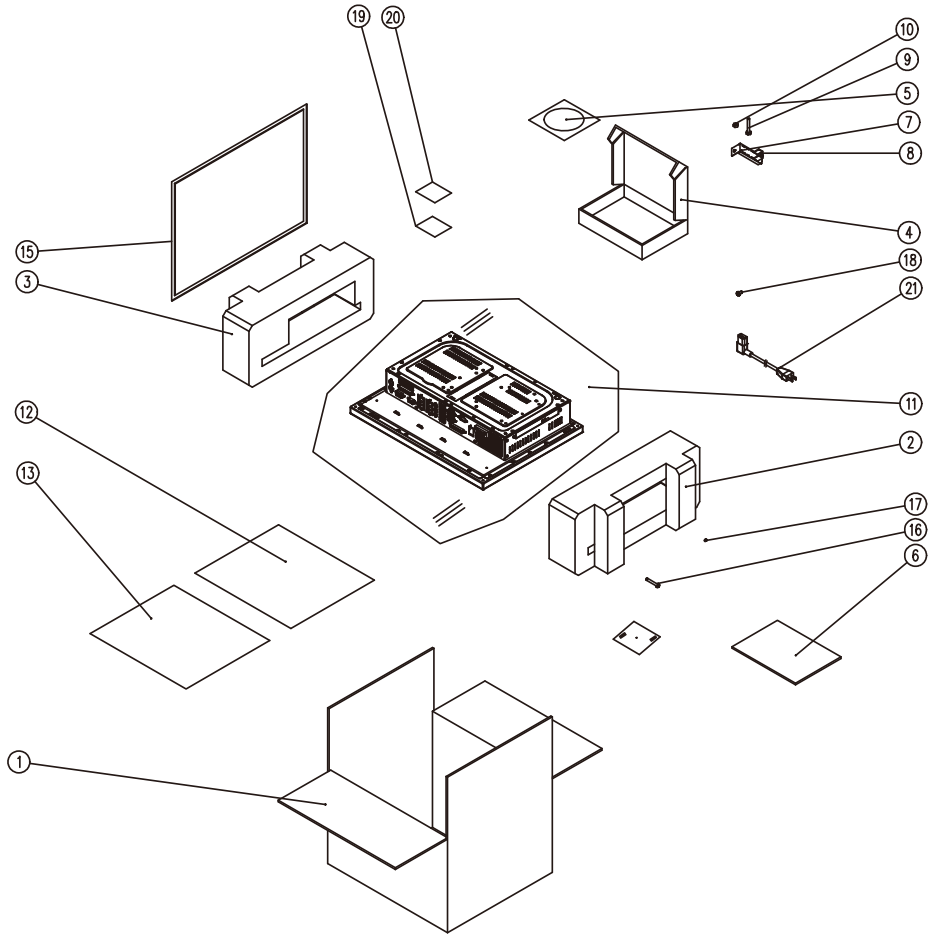



No.	P/N	QTY	Description
1		1	Carton
2	34-016-00301168	1	EPE-R
3	34-016-00302168	1	EPE-L
4	34-003-01301086	1	Component Box
5	52-601-00000101	1	Drive CD
6		1	Quick Manual
7	20-011-03061168	4	PPC-7615 Hook Base
8	20-011-03062168	4	PPC-7615 Hook Slide
9	22-252-60050011	4	Hex Head Screw
10	23-142-60501101	4	Nut
11	32-10020010000	1	PE Bag
12	30-056-02100008	1	Mylar
13	34-004-01301008	1	LCD Panel Cardboard
14	34-005-00010007	2	Drier
15	30-013-15200168	1	PPC-7615 EVA For Wall
16	22-222-40020011	12	PAN Head Screw
17	22-215-30006111	4	Screw
18	22-230-30005811	8	Screw
19	34-017-03102168	1	Model Label
20	20-005-16001000	1	PROX Label
21	27-012-17103111	1	Transfer Power Cord

## **EXPLODED DIAGRAM FOR PPC-7915F WALL MOUNTING**

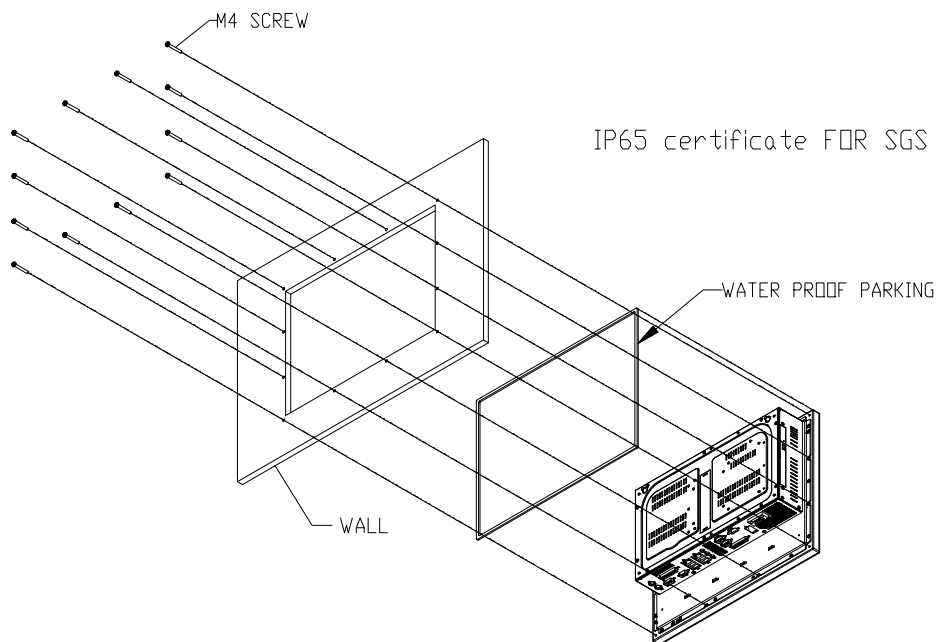

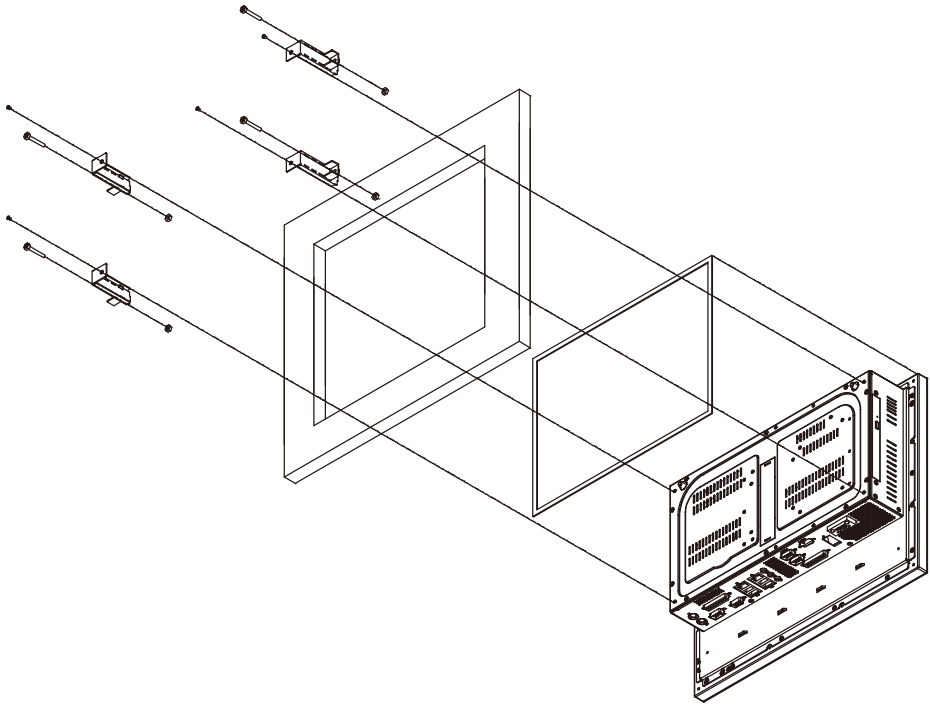

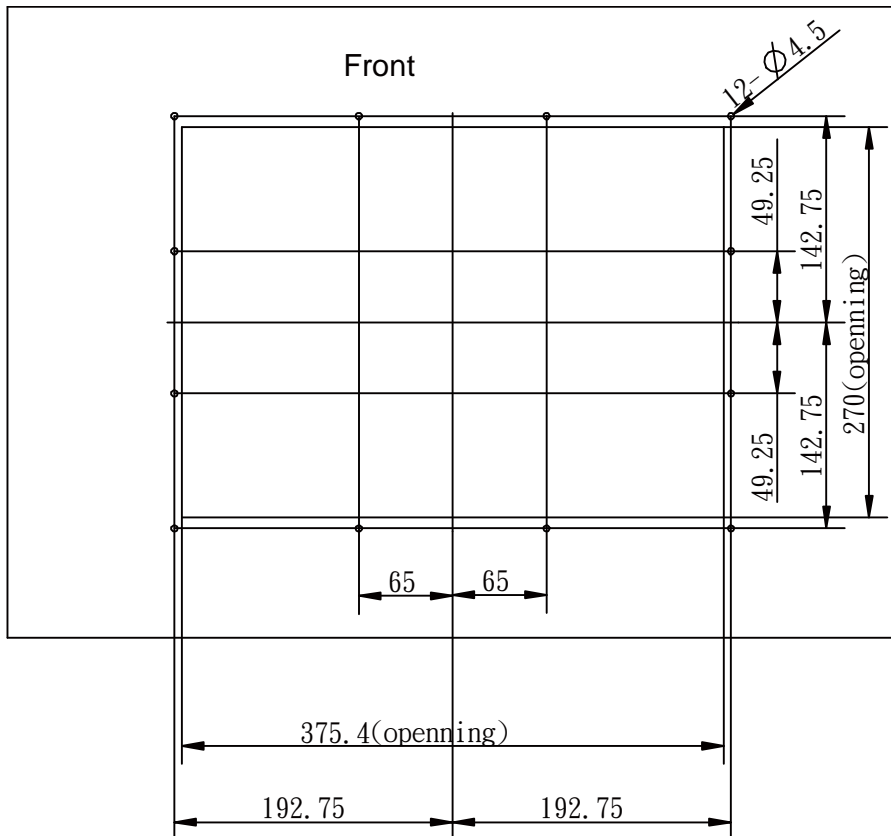

**EXPLODED DIAGRAM FOR PPC-7917F LCD PANEL**

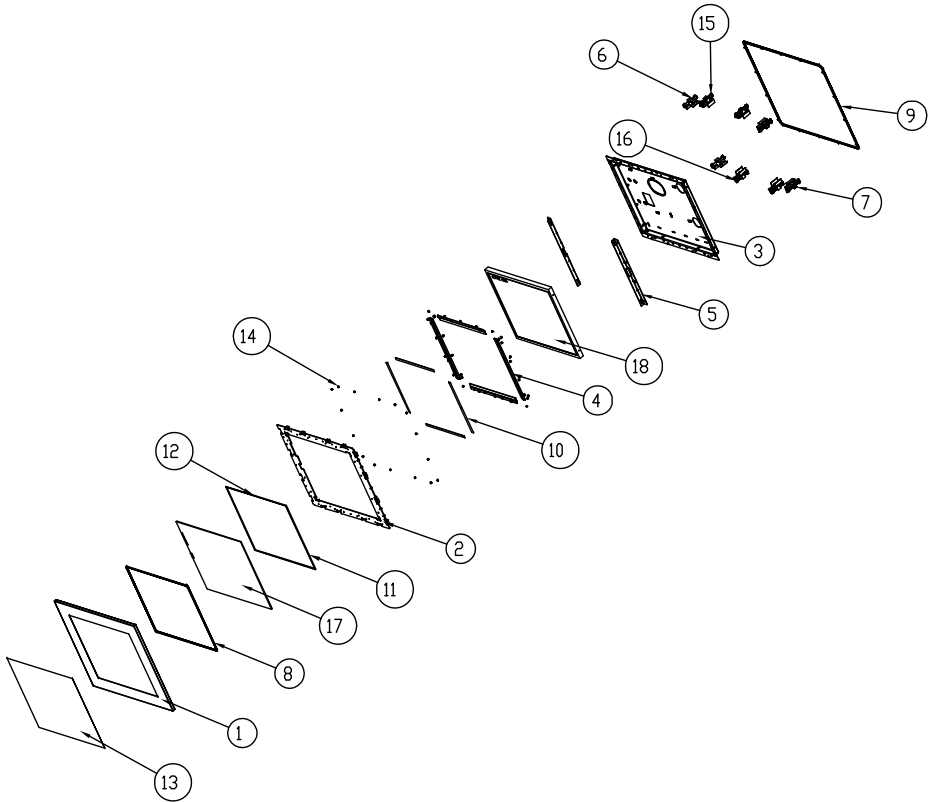

No.	Name	P/N	QTY
Metal			
1	Panel SUS Cover	20-004-07001169	1
2	Panel SECC Cover	20-004-03001169	1
3	LCD Holder	20-029-03061169	1
4	Touchscreen Packing	20-004-03002169	4
5	LCD Link Holder	20-029-03001169	2
6	Hook Fix Sheet	20-011-03002169	8
7	0_br_ear_slide	20-011-03062168	8
Rubber/ Mylar			
8	Touchscreen Oring	30-013-01100169	1
9	Wall Oring	30-013-01200169	1
10	Poron Touchscreen	30-013-24600169	4
11	Panel Sponge-1	30-013-24400169	2
12	Panel Sponge-2	30-013-24500169	2
13	17" Mylar	30-056-02100071	1
Screw			
14	M3*6 sara head screw	22-215-30006111	78
15	M6*50 screw	22-252-60050011	8
16	M6 Nut	23-142-60501101	8
17	Touch screen		1
18	LCD Panel		1

**EXPLODED DIAGRAM FOR PPC-7917F PACKING**

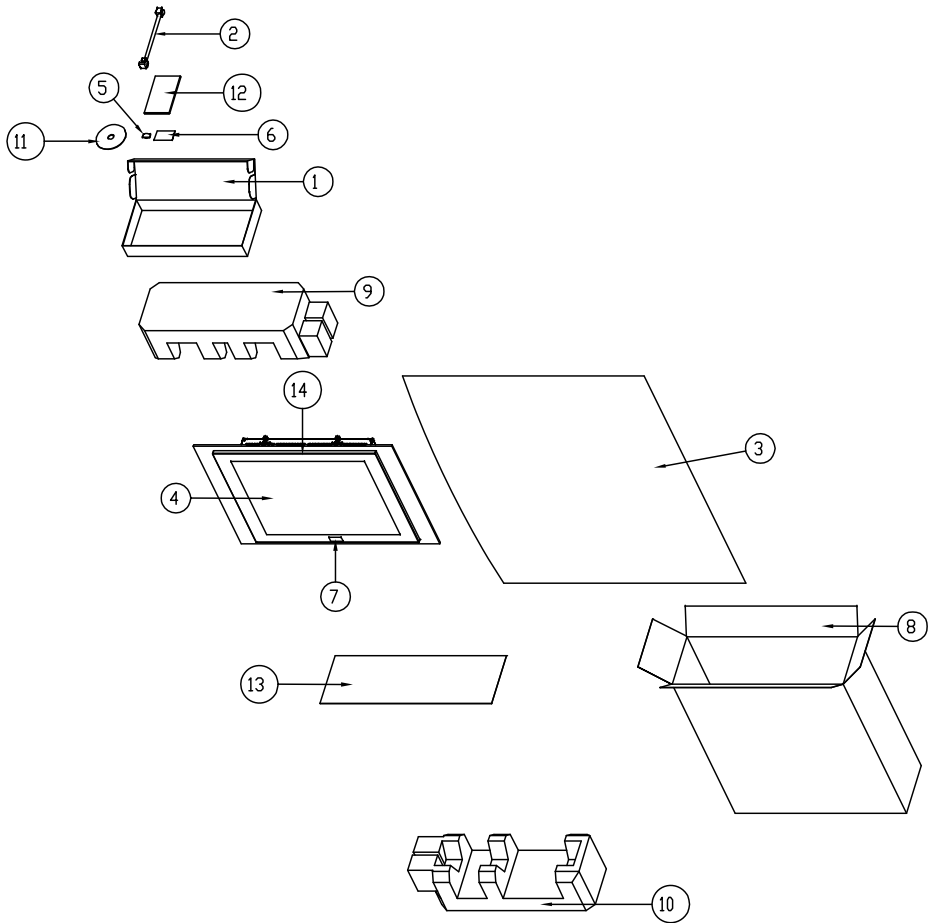

No.	Name	P/N	Qty
1	Component Box	34-003-01301086	1
2	Transfer Power Cable	27-012-17103111	1
3	PE Bag	34-010-00210003	1
4	17" Mylar	30-056-02100071	1
5	Drier	34-005-00010007	2
6	Model Label	34-017-03102168	1
7	PROX Label	20-005-16001000	1
8	Outer Carton		1
9	EPE-4602R	34-016-00301169	1
10	EPE-4602L	34-016-00302169	1
11	Drive CD	52-601-00000101	1
12	Quick Manual		1
13	LCD Panel Cardboard	34-004-01301058	1
14	PPC-7917		1



**EXPLODED DIAGRAM FOR PPC-7917F WALL MOUNTING**

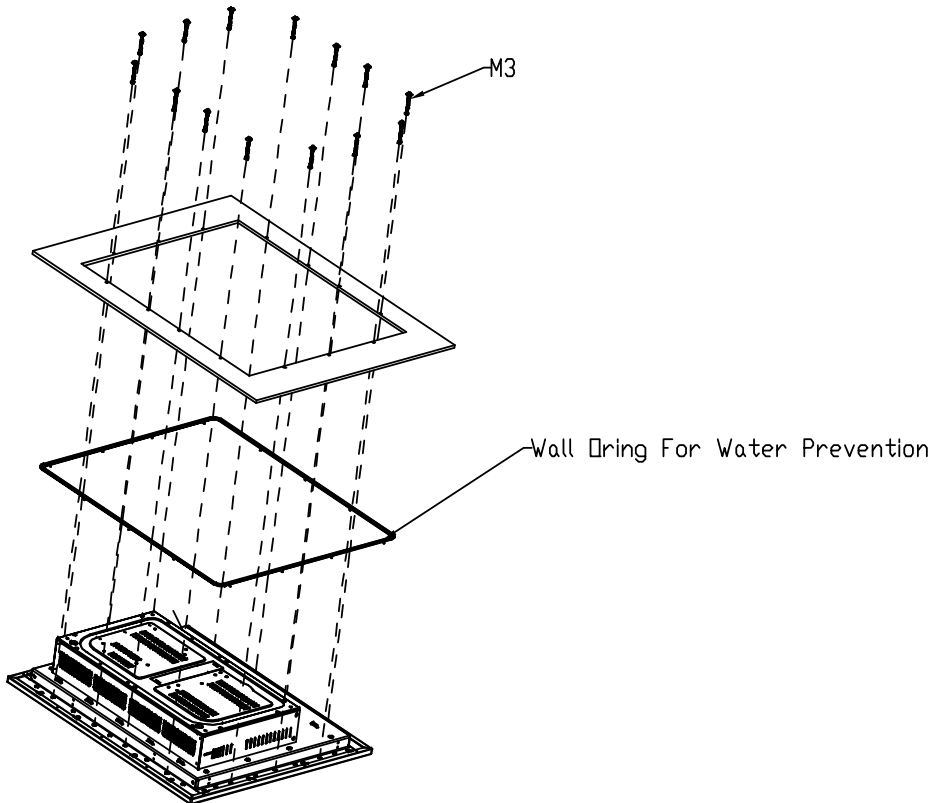

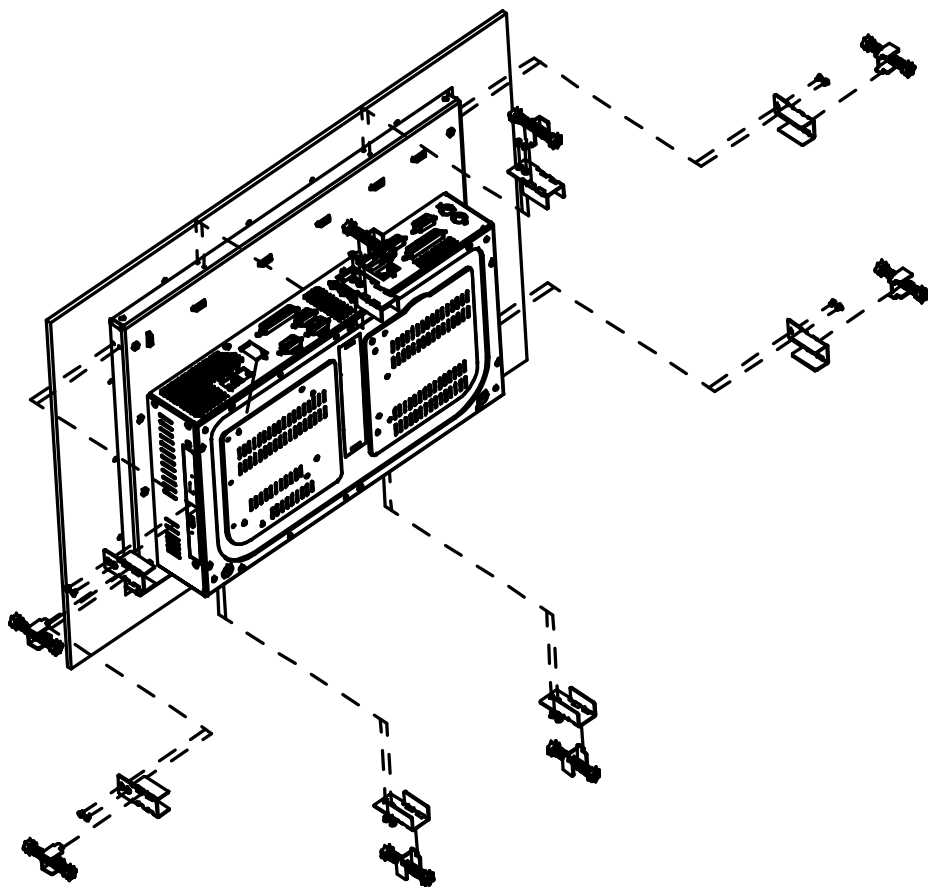

**EXPLODED DIAGRAM FOR PPC-7919F LCD PANEL**

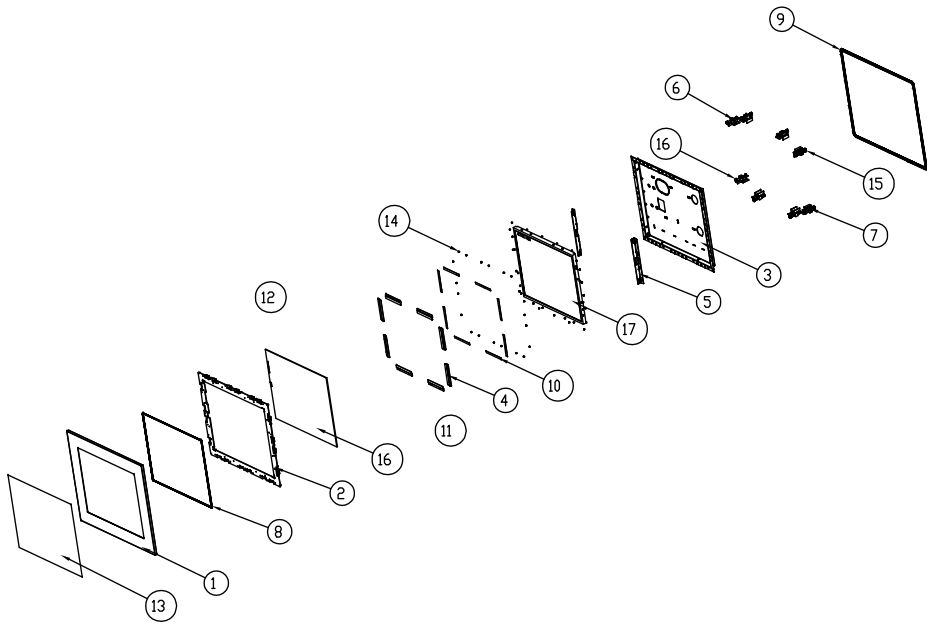

No.	Name	P/N	QTY
Metal			
1	Panel SUS Cover	20-004-07002170	1
2	Panel SECC Cover	20-004-03001170	1
3	LCD Holder	20-029-03061170	1
4	Touchscreen Packing	20-004-03002170	4
5	LCD Link Holder	20-029-03001170	2
6	Hook Fix Sheet	20-011-03002169	8
7	0_br_ear_slide	20-011-03062168	8
Rubber/ Mylar			
8	Touchscreen Oring	30-013-01100170	1
9	Wall Oring	30-013-01200170	1
10	Poron Touchscreen	30-013-24600170	4
11	Panel Sponge-1	30-013-24400170	2
12	Panel Sponge-2	30-013-24500170	2
13	19" Mylar	30-056-25500000	1
Screw			
14	M3*6 sara head screw	22-215-30006111	82
15	M6*50 screw	22-252-60050011	8
16	M6 Nut	23-142-60501101	8
17	Touch screen		1
18	LCD Panel		1

**EXPLODED DIAGRAM FOR PPC-7919F PACKING**

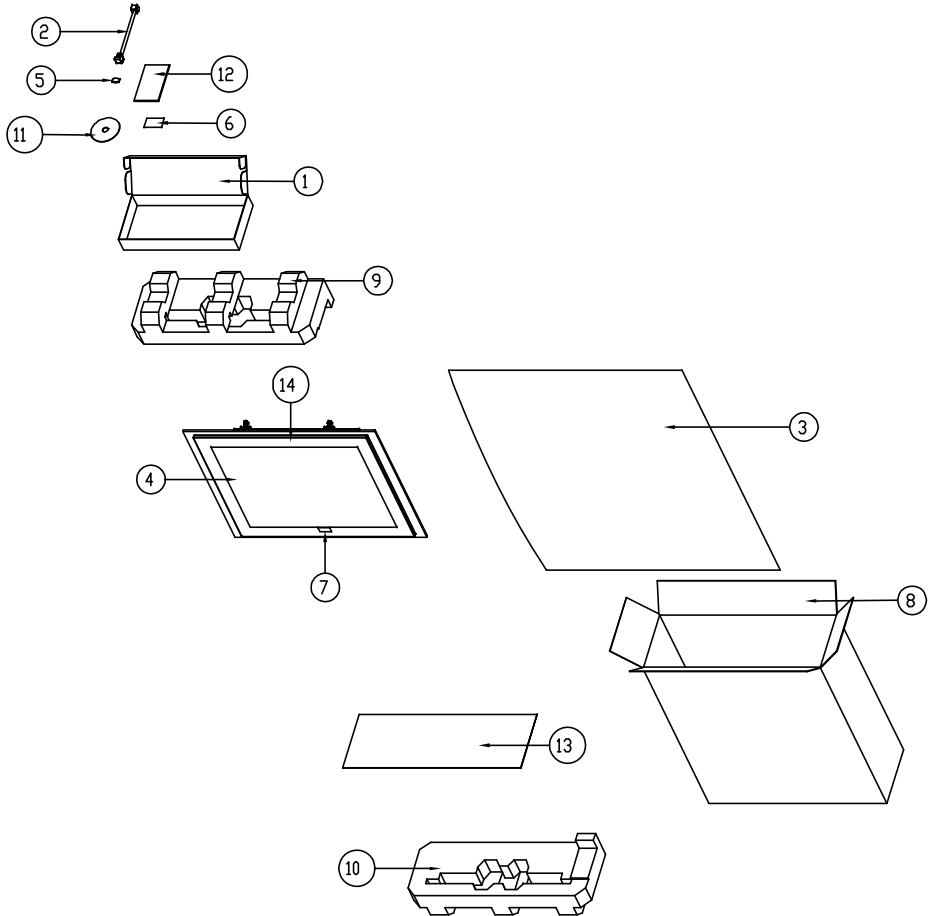

No.	Name	P/N	Qty
1	Component Box	34-003-01301086	1
2	Transfer Power Cable	27-012-17103111	1
3	PE Bag	34-010-00210003	1
4	19" Mylar	30-056-25500000	1
5	Drier	34-005-00010007	2
6	Model Label	34-017-03102168	1
7	PROX Label	20-005-16001000	1
8	Outer Carton		1
9	EPE-4602R	34-016-00301170	1
10	EPE-4602L	34-016-00302170	1
11	Drive CD	52-601-00000101	1
12	Quick Manual		1
13	LCD Panel Cardboard		1
14	PPC-7919		1

**EXPLODED DIAGRAM FOR PPC-7919F WALL MOUNTING**

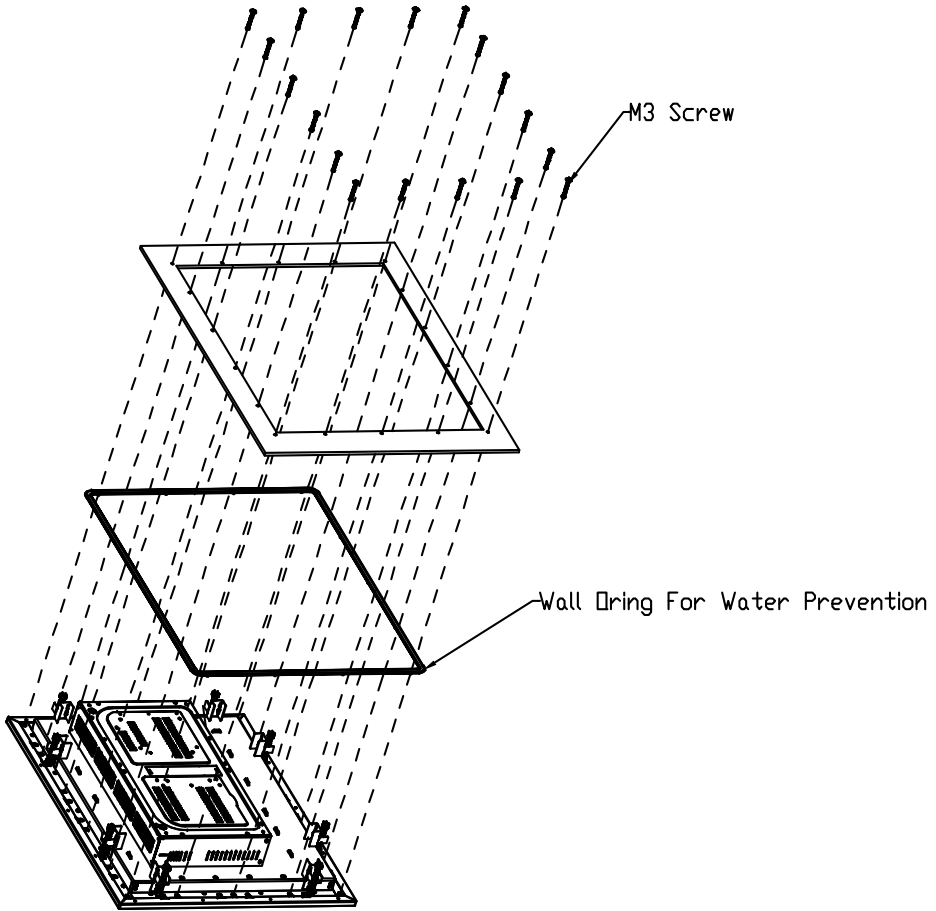

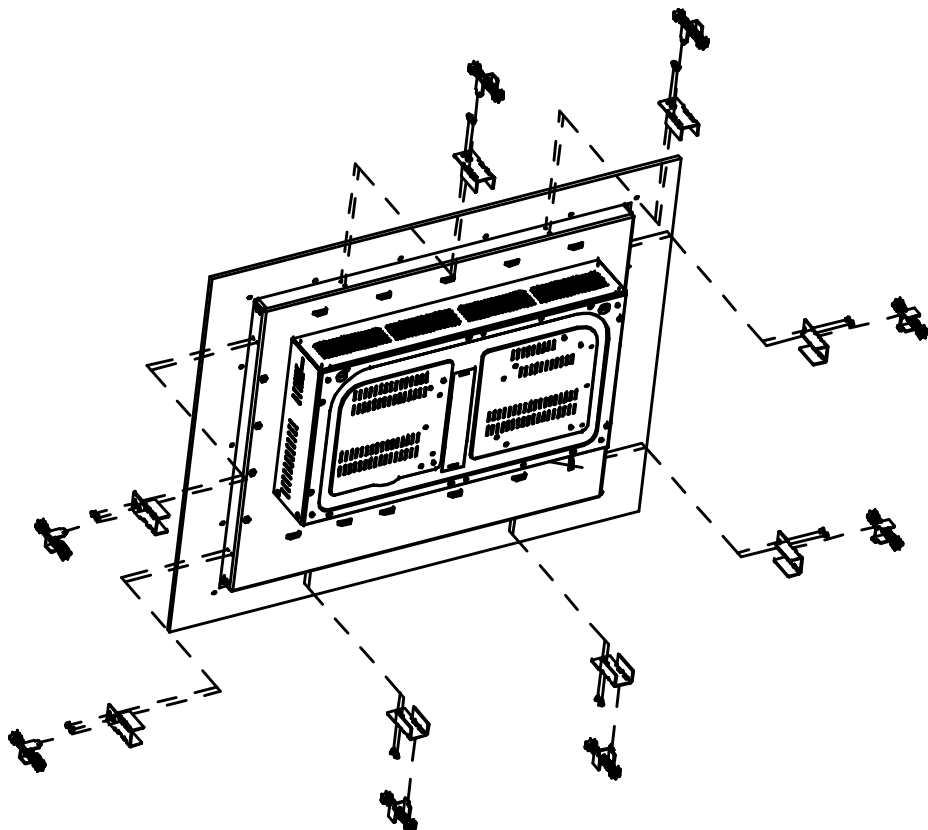



# ***TECHNICAL SUMMARY***

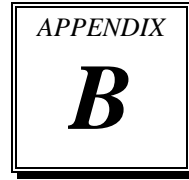

This section introduce you the maps concisely.

Section includes:

- Block Diagram
- Interrupt Map
- RTC & CMOS RAM Map
- Timer & DMA Channels Map
- I / O & Memory Map

### BLOCK DIAGRAM

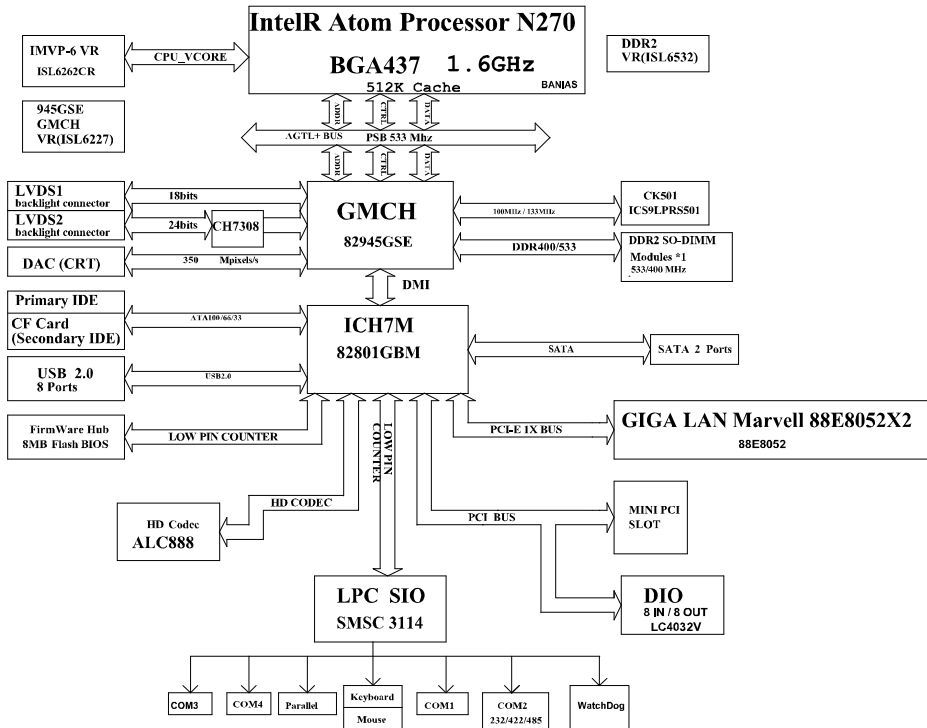

**INTERRUPT MAP**

<b>IRQ</b>	<b>ASSIGNMENT</b>
0	System TIMER
1	Keyboard
2	Cascade
3	Serial port 2
4	Serial port 1
5	Available
6	Floppy
7	Parallel port 1
8	RTC clock
9	Available
10	Available
11	Available
12	PS/2 Mouse
13	Math coprocessor
14	IDE1
15	IDE2

## **RTC & CMOS RAM MAP**

<b>CODE</b>	<b>ASSIGNMENT</b>
00	Seconds
01	Second alarm
02	Minutes
03	Minutes alarm
04	Hours
05	Hours alarm
06	Day of week
07	Day of month
08	Month
09	Year
0A	Status register A
0B	Status register B
0C	Status register C
0D	Status register D
0E	Diagnostic status byte
0F	Shutdown byte
10	Floppy Disk drive type byte
11	Reserve
12	Hard Disk type byte
13	Reserve
14	Equipment byte
15	Base memory low byte
16	Base memory high byte
17	Extension memory low byte
18	Extension memory high byte
30	Reserved for extension memory low byte
31	Reserved for extension memory high byte
32	Date Century byte
33	Information Flag
34-3F	Reserve
40-7f	Reserved for Chipset Setting Data

## TIMER & DMA CHANNELS MAP

### Timer Channel Map :

Timer Channel	Assignment
0	System timer interrupt
1	DRAM Refresh request
2	Speaker tone generator

### DMA Channel Map :

DMA Channel	Assignment
0	Available
1	Available
2	Floppy
3	Available
4	Cascade
5	Available
6	Available
7	Available

## **I/O & MEMORY MAP**

### **Memory Map :**

<b>MEMORY MAP</b>	<b>ASSIGNMENT</b>
0000000-009FFFF	System memory used by DOS and application
00A0000-00BFFFF	Display buffer memory for VGA/ EGA / CGA / MONOCHROME adapter
00C0000-00DFFFF	Reserved for I/O device BIOS ROM or RAM buffer.
00E0000-00EFFFF	Reserved for PCI device ROM
00F0000-00FFFFFF	System BIOS ROM
0100000-FFFFFFF	System extension memory

### **I/O Map :**

<b>I/O MAP</b>	<b>ASSIGNMENT</b>
000-01F	DMA controller (Master)
020-021	Interrupt controller (Master)
022-023	Chipset controller registers I/O ports.
040-05F	Timer control registers.
060-06F	Keyboard interface controller (8042)
070-07F	RTC ports & CMOS I/O ports
080-09F	DMA register
0A0-0BF	Interrupt controller (Slave)
0C0-0DF	DMA controller (Slave)
0F0-0FF	Math coprocessor
1F0-1F8	Hard Disk controller
278-27F	Parallel port-2
2B0-2DF	Graphics adapter controller
2F8-2FF	Serial port-2
360-36F	Net work ports
378-37F	Parallel port-1
3B0-3BF	Monochrome & Printer adapter
3C0-3CF	EGA adapter
3D0-3DF	CGA adapter
3F0-3F7	Floppy disk controller
3F8-3FF	Serial port-1