

USER'S MANUAL

SE-8210

**Intel® Core™ 3rd Gen. mobile
i3/i5/i7 High Performance
Fanless Embedded PC**

SE-8210 M4

SE-8210
Intel® Core™ 3rd Gen. Mobile
i3/i5/i7 High Performance
Fanless Embedded PC

COPYRIGHT NOTICE

All trademarks and registered trademarks mentioned herein are the property of their respective owners.

This manual is copyrighted in Oct. 2016. You may not reproduce or transmit in any form or by any means, electronic, or mechanical, including photocopying and recording.

DISCLAIMER

This user's manual is meant to assist you in installing and setting up the system. The information contained in this document is subject to change without any notice.

CE NOTICE

This is a class A product. In a domestic environment this product may cause radio interference in which case the user may be required to take adequate measures.

FCC NOTICE

This equipment has been tested and found to comply with the limits for a Class A digital device, pursuant to part 15 of the FCC Rules. These limits are designed to provide reasonable protection against harmful interference when the equipment is operated in a commercial environment. This equipment generates, uses, and can radiate radio frequency energy and, if not installed and used in accordance with the instruction manual, may cause harmful interference to radio communications. Operation of this equipment in a residential area is likely to cause harmful interference in which case the user will be required to correct the interference at his own expense.

You are cautioned that any change or modifications to the equipment not expressly approve by the party responsible for compliance could void your authority to operate such equipment.

CAUTION! Danger of explosion if battery is incorrectly replaced. Replace only with the same or equivalent type recommended by the manufacturer. Dispose of used batteries according to the manufacturer's instructions.

WARNING! Some internal parts of the system may have high electrical voltage. And therefore we strongly recommend that qualified engineers can open and disassemble the system.

TABLE OF CONTENTS

CHAPTER 1 INTRODUCTION

1-1	About This Manual.....	1-2
1-2	System Illustration.....	1-3
1-3	System Specifications.....	1-5
1-4	Safety Precautions.....	1-7

CHAPTER 2 SYSTEM CONFIGURATION

2-1	Jumper & Connector Quick Reference Table.....	2-2
2-2	Component Locations.....	2-4
2-3	How to Set the Jumpers.....	2-6
2-4	Clear CMOS Data Selection.....	2-8
2-5	CFast Voltage Selection.....	2-9
2-6	COM1 Connector.....	2-10
2-7	COM1 RI & Voltage Selection.....	2-11
2-8	COM2 Connector.....	2-12
2-9	COM2 RS232/422/485 Selection.....	2-13
2-10	COM2 Auto Detect Selection.....	2-14
2-11	COM2 RI & Voltage Selection.....	2-15
2-12	COM3 Connector.....	2-16
2-13	COM3 RI & Voltage Selection.....	2-17
2-14	COM4 Connector.....	2-18
2-15	COM4 RI & Voltage Selection.....	2-19
2-16	COM5 Connector.....	2-20
2-17	COM6 Connector.....	2-20
2-18	DIO Port Connector.....	2-21
2-19	Display Port Connector.....	2-22
2-20	Flash Descriptor Override Selection.....	2-23
2-21	Front Panel ATX Power Button Connector.....	2-24
2-22	Front Panel HDD LED Connector.....	2-24
2-23	Front Panel System Reset Connector.....	2-25
2-24	Front Panel Power LED Connector.....	2-25
2-25	Internal Keyboard Connector.....	2-25
2-26	Internal Mouse Connector.....	2-26
2-27	Hardware Power Fail Selection.....	2-26
2-28	JUSB Port Connector.....	2-27
2-29	LAN Connector.....	2-28
2-30	LED	2-29

2-31	LVDS Connector.....	2-29
2-32	LVDS Inverter Connector.....	2-30
2-33	LVDS Panel Brightness Control.....	2-30
2-34	LVDS Voltage Selection.....	2-31
2-35	Power Input Connector.....	2-32
2-36	Serial ATA/ SATA Power Connector.....	2-33
2-37	Sound Connector.....	2-34
2-38	System Fan Connector.....	2-35
2-39	Universal Serial BUS 3.0 Connector.....	2-36
2-40	Universal Serial BUS 2.0 Connector..	2-37
2-41	VGA Connector.....	2-38

CHAPTER 3 SOFTWARE UTILITIES

3-1	Introduction.....	3-2
3-2	Intel Chipset Software Installation Utility.....	3-3
3-3	VGA Driver Utility.....	3-4
3-4	LAN Driver Utility.....	3-5
3-5	Sound Driver Utility.....	3-6

CHAPTER 4 AMI BIOS SETUP

4-1	Introduction.....	4-2
4-2	Entering Setup.....	4-4
4-3	Main.....	4-6
4-4	Advanced.....	4-7
4-5	Chipset.....	4-35
4-6	Boot.....	4-43
4-7	Security.....	4-44
4-8	Save & Exit.....	4-45

APPENDIX A SYSTEM ASSEMBLY

	Exploded Diagram for SE-8210 Whole System.....	A-2
	Exploded Diagram for SE-8210 Wall-mount Stand.....	A-4
	Exploded Diagram for SE-8210 Packing.....	A-5
	Exploded Diagram for Mini-PCIE Card.....	A-6
	Exploded Diagram for PCIE Card.....	A-7

APPENDIX B TECHNICAL SUMMARY

	Block Diagram.....	B-2
	Interrupt Map.....	B-3

DMA Channels Map.....	B-9
I/O Map.....	B-10
Watchdog Timer Configuration.....	B-14
Flash BIOS Update.....	B-16

INTRODUCTION

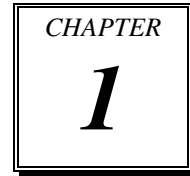

This chapter gives you the information for SE-8210. It also outlines the System specification.

Section includes:

- About This Manual
- System Specifications
- Safety Precautions

Experienced users can skip to chapter 2 on page 2-1 for Quick Start.

1-1. ABOUT THIS MANUAL

Thank you for purchasing our SE-8210 Intel® Core™ 3rd Gen. mobile i3/i5/i7 Fanless Embedded PC. SE-8210 provides faster processing speed, greater expandability and can handle more task than before. This manual is designed to assist you how to install and set up the system. It contains four chapters. The user can apply this manual for configuration according to the following chapters:

Chapter 1 Introduction

This chapter introduces you to the background of this manual, and the specifications for this system. The final page of this chapter will indicate how to avoid damaging this board.

Chapter 2 Hardware Configuration

This chapter outlines the component locations and their functions. In the end of this chapter, you will learn how to set jumper and how to configure this card to meet your own needs.

Chapter 3 Software Utilities

This chapter contains helpful information for proper installations of the VGA utility, LAN utility, and Sound utility.

Chapter 4 AMI BIOS Setup

This chapter indicates you how to set up the BIOS configurations.

Appendix A Expansion Bus

1. Expansion Bus

This appendix introduces you the PCIe / Mini-PCIe expansion bus.

2. Exploded diagram of the system

Appendix B Technical Summary

This appendix gives you the information about the Block diagram, Technical maps, Watchdog-timer configuration, and Flash BIOS Update.

1-2. SYSTEM ILLUSTRATION

Front View

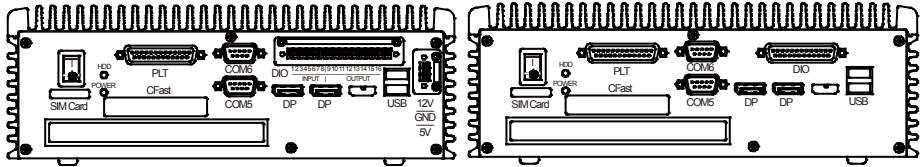

Rear View

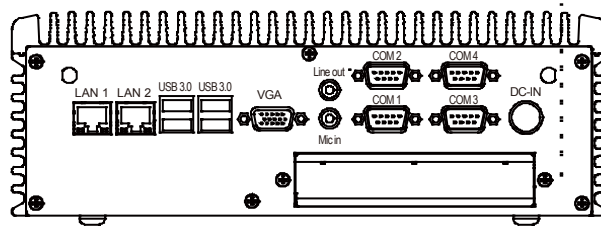

Top View

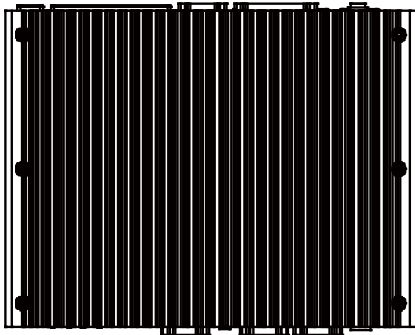

Side View

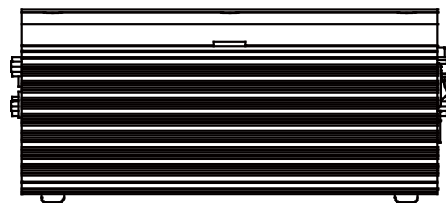

Isometric View

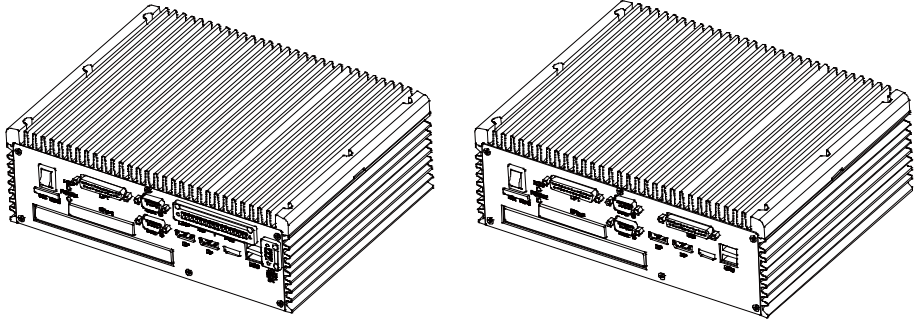

1-3. SYSTEM SPECIFICATION

System

CPU Support	Intel® mobile i3-3120ME(2.4GHz)/ i5-3610ME(2.7GHz) / i7-3610QE(2.3GHz) (rPGA-988) processor
Chipset	Intel® QM77 / HM76
Memory Support	2 x 204Pin DDR3 So-DIMM, Support DDR3/DDR3L 1600/1333/1066 up to 8GB/slot
Watchdog	1~255secs Watchdog timer
Driver Bay	2.5" SATA HDD drive bay x 1 Slim DVD-ROM X1(option)
Audio	High Definition Audio; 1 x Line-out / 1 x Mic-in
Power Supply	9~36V DC-in
Expansion Slot	1 x mini PCI-E slot (for WLAN module & 3G module) 1 x SIM card slot 1 x CFAST slot 1 x PCIe x4: 10W max./slot(option) (DVD-ROM / PCIe-expansion either)
Operating System	Microsoft Windows XP, Win7, Win8.1 32-bit, Win8.1 64-bit
Dimension (W x H x D)	260mm(W) x 89mm(H) x 200mm(D) (10.24" x 3.5" x 7.87")
System Weight	4.5 Kg
Certificate	FCC / CE

I/O Ports (Front side)

Serial Port	2 ports support (COM 5/6 for RS232 only)
Digital I/O	DSUB-25,8in/8out or Phoenix-16p (option)
USB	2 x USB2.0
Parallel port	1 x DSUB-25
Display port	2 x
SIM card / CFAST slot	1 x / 1x

I/O Ports (Rear side)

Serial Port	4 ports support (COM1/3/4 for RS232, COM2 for RS232/422/485, pin-9 5V/12V/RI selectable)
VGA	1 x VGA
LAN	LAN1 : Intel® 82579LM 10/100/1000 LAN LAN2 : Intel® 82583V 10/100/1000 LAN Support wake-on-LAN
Audio	1 x Line out, 1 x Mic-in
USB	4 x USB3.0
DC-IN	1 x 9~36V (DIN type 4 pin connector)

Environment

Operation Temp. Ambient with air flow	HDD:-5°C ~45°C CFast card (Wide-Temp grade):-5°C ~ 55°C (w/o Audio)
Storage Temp.	- 20°C ~ 80°C
Humidity	10% ~ 90%

1-4. SAFETY PRECAUTIONS

Follow the messages below to avoid your systems from damage:

1. Keep your system away from static electricity on all occasions.
2. Prevent electric shock. Don't touch any components of this card when the card is power-on. Always disconnect power when the system is not in use.
3. Disconnect power when you change any hardware devices. For instance, when you connect a jumper or install any cards, a surge of power may damage the electronic components or the whole system.

HARDWARE CONFIGURATION

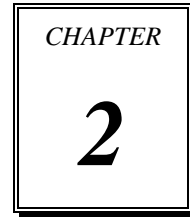

***** QUICK START *****

Helpful information describes the jumper & connector settings, and component locations.

Section includes:

- Jumper & Connector Quick Reference Table
- Component Locations
- Configuration and Jumper settings
- Connector's Pin Assignments

2-1. JUMPER & CONNECTOR QUICK REFERENCE TABLE

JUMPER / CONNECTOR	NAME
Clear CMOS Data Selection	JP5
CFAST Voltage Selection	JP8
COM1 Connector	COM1
COM1 RI & Voltage Selection	JP18
COM2 Connector	COM2
COM2 RS232/422/485 Selection	JP13
COM2 Auto Detect Selection	JP12
COM2 RI & Voltage Selection	JP17
COM3 Connector	COM3
COM3 RI & Voltage Selection	JP16
COM4 Connector	COM4
COM4 RI & Voltage Selection	JP15
COM5 Connector	COM5
COM6 Connector	COM6
DIO Connector	DIO1
Display Port Connector	DP1, DP2
Flash Descriptor Override	JP3
Front Panel ATX Power Button Connector	PWRBTN1
Front Panel HDD LED Connector	HDDLED1
Front Panel System Reset Connector	SYSRST1
Front Panel Power LED Connector	PWRLED1
Internal Keyboard Connector	KB1
Internal Mouse Connector	MS1
Hardware Power Fail Selection	JP7
JUSB Port Connector	JUSB1
LAN Connector	LAN1, LAN2

JUMPER / CONNECTOR	NAME
LED	LED1
LVDS Connector	LVDS1
LVDS Inverter Connector	INV1
LVDS Panel Brightness Control	JP21
LVDS Voltage Selection	JP19
Power Input Connector	PWR_IN1, ATX_PWR1
SATA Connector & SATA Power Connector	SATA1, SATA_PWR1, SATA2, SATA_PWR2
Sound Connector	AUDIO1, LINE_IN1
System Fan Connector	SYS_FAN1
USB3.0 Connector	USB1, USB2
USB2.0 Connector	USB4, USB5
VGA Connector	VGA1

2-2. COMPONENT LOCATIONS

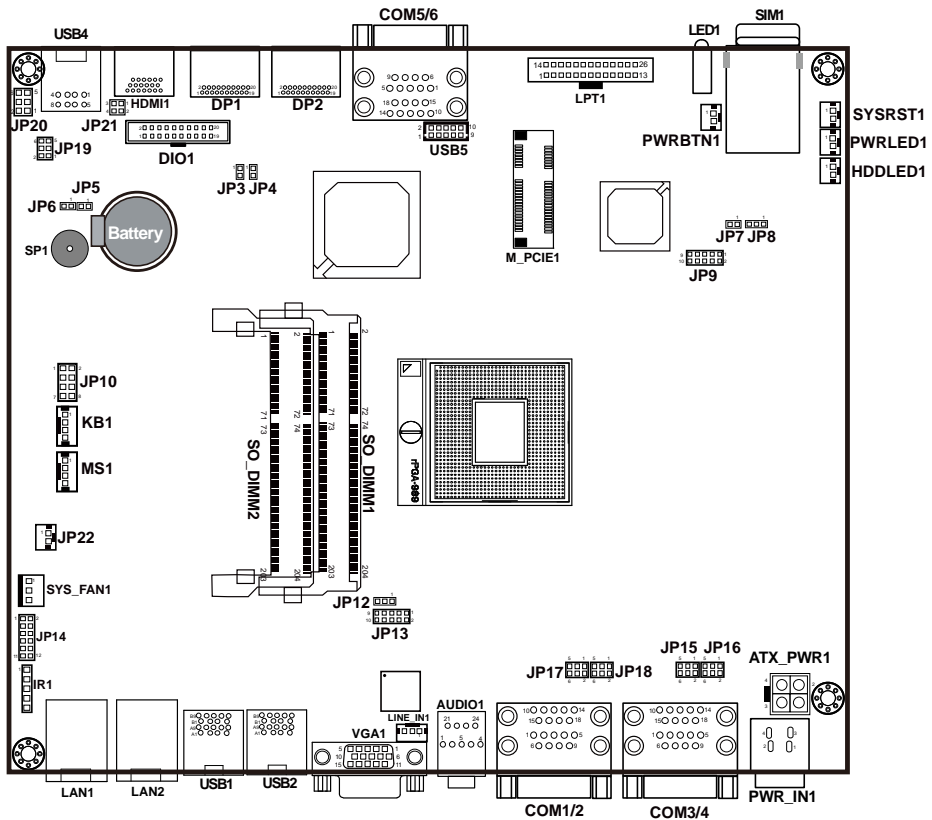

SB-8120 Front Side Connectors, Jumpers and Components Locations

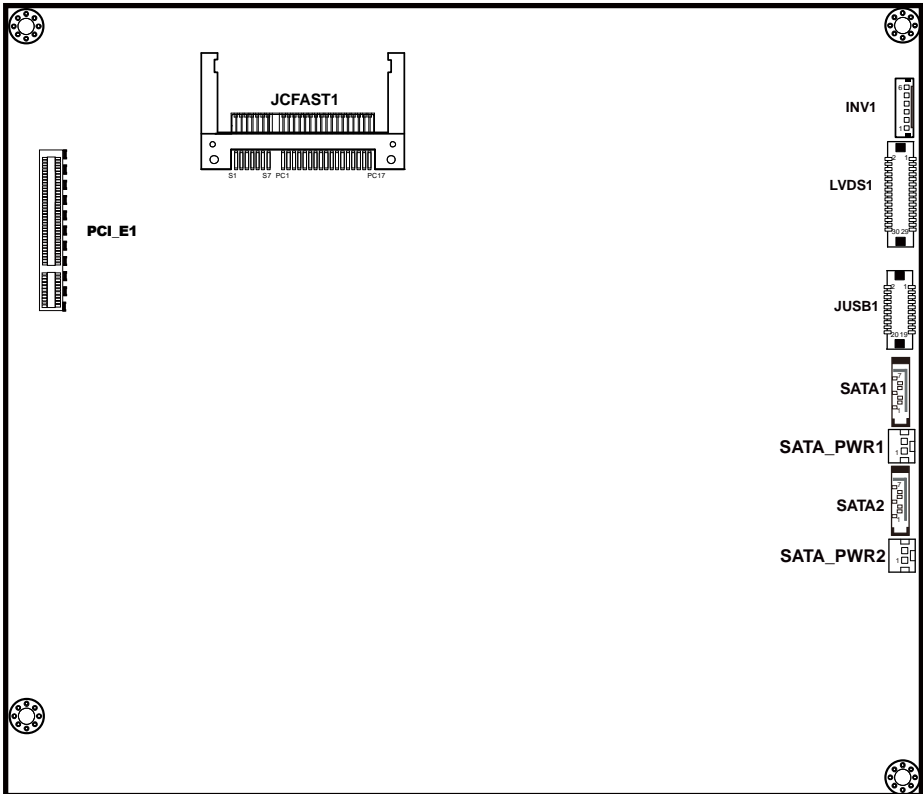

SB-8120 Rear Side Connectors, Jumpers and Components Locations

2-3. HOW TO SET THE JUMPERS

You can configure your board by setting jumpers. Jumper is consists of two or three metal pins with a plastic base mounted on the card, and by using a small plastic "cap", Also known as the jumper cap (with a metal contact inside), you are able to connect the pins. So you can set-up your hardware configuration by "open" or "close" pins.

The jumper can be combined into sets that called jumper blocks. When the jumpers are all in the block, you have to put them together to set up the hardware configuration. The figure below shows how this looks like.

JUMPERS AND CAPS

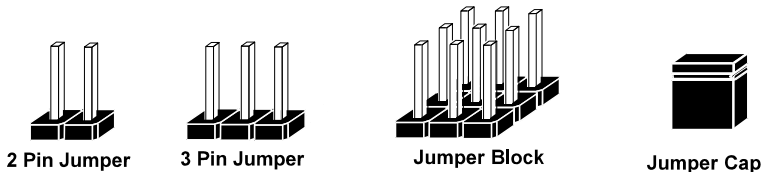

If a jumper has three pins (for examples, labelled PIN1, PIN2, and PIN3), You can connect PIN1 & PIN2 to create one setting by shorting. You can either connect PIN2 & PIN3 to create another setting. The same jumper diagrams are applied all through this manual. The figure below shows what the manual diagrams look and what they represent.

JUMPER DIAGRAMS



Jumper Cap
looks like this

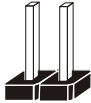

2 pin Jumper
looks like this

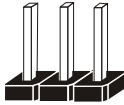

3 pin Jumper
looks like this



Jumper Block
looks like this

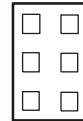

JUMPER SETTINGS



2 pin Jumper close(enabled)
Looks like this



3 pin Jumper
2-3 pin close(enabled)
Looks like this

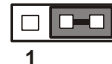

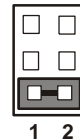

Jumper Block
1-2 pin close(enabled)
Looks like this



2-4 CLEAR CMOS DATA SELECTION

JP5 : Clear CMOS Data Selection

The selections are as follows:

FUNCTION	JUMPER SETTING (pin closed)	JUMPER ILLUSTRATION
Clear CMOS	Close	 1 JP5
Normal	Open	 1 JP5



*** Manufacturing Default - Normal.

Note: To clear CMOS data, users must power off the computer and set the jumper to "Clear CMOS" as illustrated above. After five to six seconds, set the jumper back to "Normal" and power on the computer.

2-5. CFAST VOLTAGE SELECTION

JP8 : CFAST Voltage Selection

The jumper settings are as follows:

FUNCTION	JUMPER SETTING (pin closed)	JUMPER ILLUSTRATION
3.3V	1-2	 <p>JP8</p>
5V	2-3	 <p>JP8</p>

*** Manufacturing Default – 3.3V.

2-6. COM1 CONNECTOR

COM1: COM Port Connector

COM1 is fixed as RS-232.

The pin assignments are as follows:

PIN	ASSIGNMENT
1	DCD#
2	RX
3	TX
4	DTR#
5	GND
6	DSR#
7	RTS#
8	CTS#
9	RI#

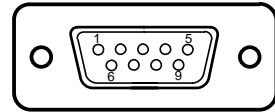



COM1

2-7. COM1 RI & VOLTAGE SELECTION

JP18 : COM1 RI & Voltage Selection

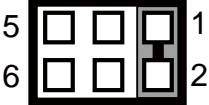
The selections are as follows:

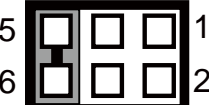
SELECTION	JUMPER SETTINGS	JUMPER ILLUSTRATION
RI	1-2	 <p>JP18</p>
12V	3-4	 <p>JP18</p>
5V	5-6	 <p>JP18</p>

***Manufacturing Default –RI.

2-8. COM2 CONNECTOR

COM2: COM Port Connector

The COM2 is selectable as RS-232/422/485.

The pin assignments are as follows:

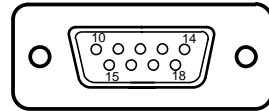

COM2



PIN	ASSIGNMENT		
	RS-232	RS-422	RS-485
10	DCD#	TX-	RS-485-
11	RX	TX+	RS-485+
12	TX	RX+	X
13	DTR#	RX-	X
14	GND	GND	GND
15	DSR#	X	X
16	RTS#	X	X
17	CTS#	X	X
18	RI#	X	X

2-9. COM2 RS232/422/485 SELECTION

JP13 : (COM2) RS-232/422/485 Selection

This connector is used to set the COM2 function.

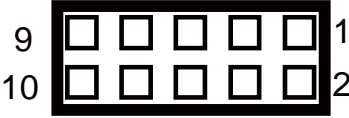
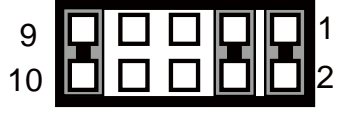
The jumper settings are as follows:

COM2 Function	Jumper Settings (pin closed)	Jumper Illustrations
RS-232	All Open	 <p style="text-align: center;">JP13</p>
RS-422	1-2, 3-4, 9-10	 <p style="text-align: center;">JP13</p>
RS-485	1-2, 5-6, 7-8	 <p style="text-align: center;">JP13</p>



*** Manufacturing default - RS-232.

2-10. COM2 AUTO DETECT SELECTION

JP12 : COM2 Auto Detect Selection

This connector is used to set the COM2 function.

The jumper settings are as follows:

FUNCTION	JUMPER SETTING (pin closed)	JUMPER ILLUSTRATION
Normal	1-2	 JP12
Auto	2-3	 JP12

*** Manufacturing Default - Auto.

2-11. COM2 RI & VOLTAGE SELECTION

JP17 : COM2 RI & Voltage Selection

The selections are as follows:

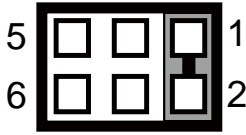
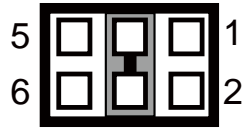
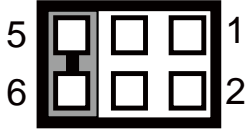
FUNCTION	JUMPER SETTING (pin closed)	JUMPER ILLUSTRATION
RI	1-2	 <p style="font-size: 2em; font-weight: bold; margin-top: 10px;">JP17</p>
12V	3-4	 <p style="font-size: 2em; font-weight: bold; margin-top: 10px;">JP17</p>
5V	5-6	 <p style="font-size: 2em; font-weight: bold; margin-top: 10px;">JP17</p>

***Manufacturing Default –RI.

2-12. COM3 CONNECTOR

COM3: COM Port Connector

COM3 is fixed as RS-232.

The pin assignments are as follows:

PIN	ASSIGNMENT
1	DCD#
2	RX
3	TX
4	DTR#
5	GND
6	DSR#
7	RTS#
8	CTS#
9	RI#

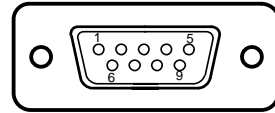

COM3

2-13. COM3 RI & VOLTAGE SELECTION

JP16 : COM3 RI & Voltage Selection

The selections are as follows:

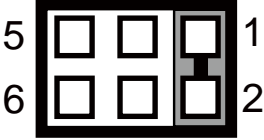
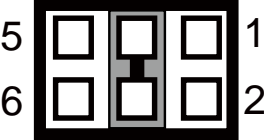
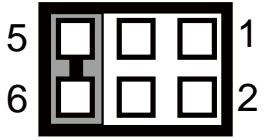
SELECTION	JUMPER SETTINGS	JUMPER ILLUSTRATION
RI	1-2	 <p style="text-align: center;">JP16</p>
12V	3-4	 <p style="text-align: center;">JP16</p>
5V	5-6	 <p style="text-align: center;">JP16</p>

***Manufacturing Default –RI.

2-14. COM4 CONNECTOR

COM4: COM Port Connector

COM4 is fixed as RS-232.

The pin assignments are as follows:

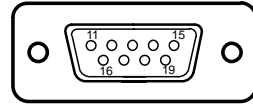



COM4

PIN	ASSIGNMENT
11	DCD#
12	RX
13	TX
14	DTR#
15	GND
16	DSR#
17	RTS#
18	CTS#
19	RI#

2-15. COM4 RI & VOLTAGE SELECTION

JP15 : COM4 RI & Voltage Selection

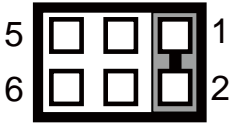
The selections are as follows:

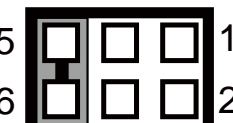
SELECTION	JUMPER SETTINGS	JUMPER ILLUSTRATION
RI	1-2	 <p>JP15</p>
12V	3-4	 <p>JP15</p>
5V	5-6	 <p>JP15</p>

***Manufacturing Default –RI.

2-16. COM5 CONNECTOR

COM5: COM Port Connector

COM5 is fixed as RS-232.

The pin assignments are as follows:

PIN	ASSIGNMENT
1	DCD#
2	RX
3	TX
4	DTR#
5	GND
6	DSR#
7	RTS#
8	CTS#
9	RI#

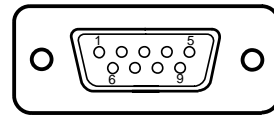

COM5

2-17. COM6 CONNECTOR

COM6: COM Port Connector

COM6 is fixed as RS-232.

The pin assignments are as follows:

PIN	ASSIGNMENT
11	DCD#
12	RX
13	TX
14	DTR#
15	GND
16	DSR#
17	RTS#
18	CTS#
19	RI#

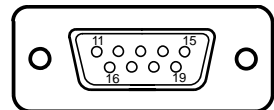

COM6

2-18. DIO PORT CONNECTOR

DIO1: M/B DIO Port Connector 20 pins

The pin assignments are as follows:



DIO1

PIN	ASSIGNMENT	PIN	ASSIGNMENT
1	VCC5	2	VCC12
3	DIN1-	4	DOUT1
5	DIN2	6	DOUT2
7	DIN3	8	DOUT3
9	DIN4	10	DOUT4
11	DIN5	12	DOUT5-
13	DIN6	14	DOUT6
15	DIN7	16	DOUT7
17	DIN8	18	DOUT8
19	GND	20	GND

System Digital I/O Port DSUB-25 pin

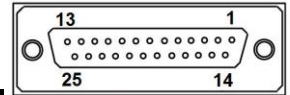

DIO Port

PIN	ASSIGNMENT	PIN	ASSIGNMENT
1	DIN1	2	DIN2
3	DIN3	4	DIN4
5	DIN5	6	DIN6
7	DIN7	8	DIN8
9	NC	10	NC
11	NC	12	VCC5
13	GND	14	DOUT1
15	DOUT2	16	DOUT3
17	DOUT4	18	DOUT5
19	DOUT6	20	DOUT7
21	DOUT8	22	NC
23	NC	24	VCC12
25	GND	-	-

2-19. DISPLAY PORT CONNECTOR

DP1 : Display Port Connector.
The pin assignments are as follows:



PIN	ASSIGNMENT	PIN	ASSIGNMENT
1	DATA0+	2	GND
3	DATA0-	4	DATA1+
5	GND	6	DATA1-
7	DATA2+	8	GND
9	DATA2-	10	DATA3+
11	GND	12	DATA3-
13	AUX_EN#	14	GND
15	AUX+	16	HPD
17	AUX-	18	VCC3
19	VCC5	20	VCC3

DP2: Display Port Connector.
The pin assignments are as follows:



PIN	ASSIGNMENT	PIN	ASSIGNMENT
1	DATA0+	2	GND
3	DATA0-	4	DATA1+
5	GND	6	DATA1-
7	DATA2+	8	GND
9	DATA2-	10	DATA3+
11	GND	12	DATA3-
13	AUX_EN#	14	GND
15	AUX+	16	HPD
17	AUX-	18	VCC3
19	VCC5	20	VCC3

2-20. Flash Descriptor Override Selection

JP3 : Flash Descriptor Override Selection.

The selections are as follows:

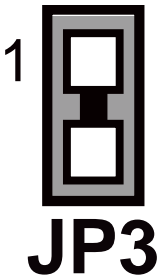
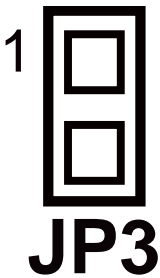
FUNCTION	JUMPER SETTING	JUMPER ILLUSTRATION
Enable	Close	 A diagram of a two-pin jumper labeled 'JP3'. The jumper is shown as a vertical bar with two rectangular pins. A horizontal bar connects the two pins, indicating the jumper is closed. A small number '1' is positioned to the left of the top pin.
Disable	Open	 A diagram of a two-pin jumper labeled 'JP3'. The jumper is shown as a vertical bar with two rectangular pins. There is no horizontal bar connecting the pins, indicating the jumper is open. A small number '1' is positioned to the left of the top pin.

*** Manufacturing Default is set as Disable.

2-21. FRONT PANEL ATX POWER BUTTON CONNECTOR

PWRBTN1: ATX Power Button

The pin assignments are as follows:

PIN	ASSIGNMENT
1	PWR_BTN
2	GND



PWRBTN1

2-22. FRONT PANEL HDD LED CONNECTOR

HDDLED1 : Hard Disk Drive LED Connector

The pin assignments are as follows:

PIN	ASSIGNMENT
1	HDD_LED+
2	HDD_LED-



HDDLED1

2-23. FRONT PANEL SYSTEM RESET CONNECTOR

SYSRST1 : Reset Connector

The pin assignments are as follows:

PIN	ASSIGNMENT
1	RST_BTN
2	GND



2-24. FRONT PANEL POWER LED CONNECTOR

PWRLED1 : Power LED Connector

The pin assignments are as follows:

PIN	ASSIGNMENT
1	PWR_LED+
2	GND

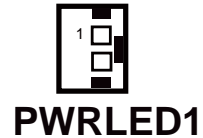

2-25. INTERNAL KEYBOARD CONNECTOR

KB1 : Keyboard Connector

The pin assignments are as follows:

PIN	ASSIGNMENT
1	KBCLK
2	KBDATA
3	GND
4	5VSB

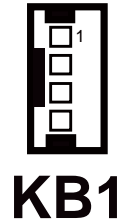

2-26. INTERNAL MOUSE CONNECTOR

MS1 : Mouse Connector

The pin assignments are as follows:

PIN	ASSIGNMENT
1	MSCLK
2	MSDATA
3	GND
4	5VSB

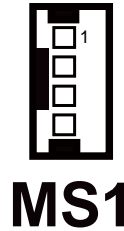

2-27. HARDWARE POWER FAIL SELECTION

JP7 : Hardware Power Failure Selection.

The selections are as follows:

FUNCTION	JUMPER SETTING	JUMPER ILLUSTRATION
Enable	Close	JP7
Disable	Open	JP7

*** Manufacturing Default is set as Disable.

2-28. JUSB PORT CONNECTOR

JUSB1 : USB Port Connector.

The pin assignments are as follows:

PIN	ASSIGNMENT	PIN	ASSIGNMENT
1	5VSB	2	5VSB
3	USB_N4	4	12V
5	USB_P4	6	12V
7	GND	8	12V
9	LVDS_BKLT_EN	10	12V
11	USB_N5	12	12V
13	USB_P5	14	CSATA_LED
15	GND	16	PWR_LED_R
17	GND-	18	USB_OCI1
19	5V	20	USB_OCI2

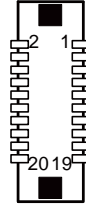

JUSB1

2-29. LAN CONNECTOR

LAN1: LAN Connector

The pin assignments are as follows:

PIN	ASSIGNMENT
1	MDI_P0
2	MDI_N0
3	MDI_P1
4	MDI_N1
5	MDI_P2
6	MDI_N2
7	MDI_P3
8	MDI_N3

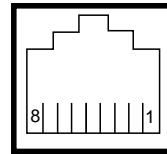

LAN1

LAN LED indicator

Left Side LED

Green Color On7	10/100 LAN Speed Indicator
Orange Color On8	Giga LAN Speed Indicator
Off	No LAN Switch/HUB connect

Right Side LED

Yellow Color Blinking	LAN Message Active
Off	No LAN Message Active

LAN2: LAN Connector

The pin assignments are as follows:

PIN	ASSIGNMENT
1	MDI_P0
2	MDI_N0
3	MDI_P1
4	MDI_N1
5	MDI_P2
6	MDI_N2
7	MDI_P3
8	MDI_N3

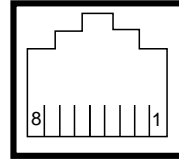

LAN2

LAN LED Indicator

Left Side LED

Green Color On7	10/100 LAN Speed Indicator
Orange Color On8	Giga LAN Speed Indicator
Off	No LAN Switch/HUB connect

Right Side LED

Yellow Color Blinking	LAN Message Active
Off	No LAN Message Active

2-30. LED

LED1: Power and HDD LED
 The pin assignment as follows:

PIN	ASSIGNMENT
1	PWR_LED
2	GND
3	HDD_LED+
4	HDD_LED-



2-31. LVDS CONNECTOR

LVDS1: LVDS Connector
 The pin assignments are as follows:

PIN	ASSIGNMENT	PIN	ASSIGNMENT
1	LVDS_VCC	2	GND
3	LVDS1_CLK- (Even)	4	LVDS1_CLK+ (Even)
5	GND	6	LVDS1_D2- (Even)
7	LVDS1_D2+ (Even)	8	GND
9	LVDS1_D1- (Even)	10	LVDS1_D1+ (Even)
11	LVDS1_D3+ (Even)	12	LVDS1_D3- (Even)
13	LVDS1_D0+ (Even)	14	LVDS1_D0- (Even)
15	GND	16	LVDS0_CLK+ (Odd)
17	LVDS0_CLK- (Odd)	18	GND
19	LVDS0_D2+ (Odd)	20	LVDS0_D2- (Odd)
21	GND	22	LVDS0_D1+ (Odd)
23	LVDS0_D1- (Odd)	24	GND
25	LVDS0_D0+ (Odd)	26	LVDS0_D0- (Odd)
27	LVDS0_D3+ (Odd)	28	LVDS0_D3- (Odd)
29	LVDS_VCC	30	LVDS_VCC

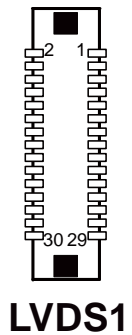

2-32. LVDS INVERTER CONNECTOR

INV1: Inverter Connector

The pin assignments are as follows:

PIN	ASSIGNMENT
1	VCC12
2	VCC12
3	GND
4	VCC5
5	GND
6	ENABKL

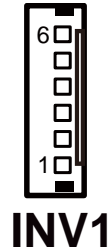

2-33. LVDS PANEL BRIGHTNESS CONTROL

JP21 : LVDS Panel Brightness Control

The selections are as follows:

FUNCTION	JUMPER SETTING (pin closed)	JUMPER ILLUSTRATION
UP	1-2	<p style="text-align: center;">JP21</p>
DOWN	3-4	<p style="text-align: center;">JP21</p>

2-34. LVDS VOLTAGE SELECTION

JP19: LVDS Voltage Selection

The selections are as follows:

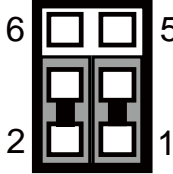
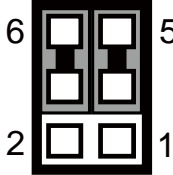
FUNCTION	JUMPER SETTING (pin closed)	JUMPER ILLUSTRATION
3.3V	1-3, 2-4	 <p style="text-align: center;">JP19</p>
5V	3-5, 4-6	 <p style="text-align: center;">JP19</p>

*** Manufacturing Default – 3.3V.

2-35. POWER INPUT CONNECTOR

PWR_IN1: Power Input Connector

The pin assignments are as follows:

PIN	ASSIGNMENT
1	GND
2	GND
3	VCC
4	VCC

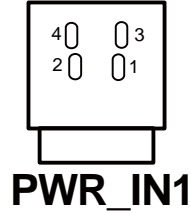

ATX_PWR1: Option Power Input Connector

The pin assignments are as follows:

PIN	ASSIGNMENT
1	GND
2	GND
3	VCC
4	VCC

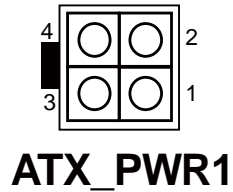

2-36. SERIAL ATA / SATA POWER CONNECTOR

SATA1: SATA Connector

The pin assignments are as follows:

PIN	ASSIGNMENT
1	GND
2	SATA_TXP0
3	SATA_TXN0
4	GND
5	SATA_RXN0
6	SATA_RXP0
7	GND



SATA1

SATA_PWR1: SATA Power connector

The pin assignment as follows:

PIN	ASSIGNMENT
1	VCC5
2	GND

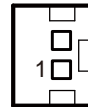

SATA_PWR1

SATA2: SATA Connector

PIN	ASSIGNMENT
1	GND
2	SATA_TXP1
3	SATA_TXN1
4	GND
5	SATA_RXN1
6	SATA_RXP1
7	GND



SATA2

SATA_PWR2: SATA Power connector

The pin assignment as follows:

PIN	ASSIGNMENT
1	VCC5
2	GND



SATA_PWR2

2-37. SOUND CONNECTOR

AUDIO1: Sound Connector

The pin assignments are as follows:

AUDIO1 MIC_IN

PIN	ASSIGNMENT
1	MIC_IN_R
2	NC
3	NC
4	MIC_IN_L
5	GND

AUDIO1 LINE_OUT

PIN	ASSIGNMENT
21	LINE_OUT_R
22	NC
23	NC
24	LINE_OUT_L

LINE_IN1

PIN	ASSIGNMENT
1	LINE_IN_R
2	GND
3	LINE_IN_L

Line-Out



Mic-In



LINE_IN1

2-38. SYSTEM FAN CONNECTOR

SYS_FAN1: System Fan connector
The pin assignments are as follows:

PIN	ASSIGNMENT
1	GND
2	SYS_FAN_CTL
3	SYS_FAN_TAC



2-39. UNIVERSAL SERIAL BUS 3.0 CONNECTOR

USB1: Universal Serial Bus Connector
The pin assignments are as follows:

PIN	ASSIGNMENT	PIN	ASSIGNMENT
A1	USB_VCC5	B1	USB_VCC5
A2	USB_N1	B2	USB_N2
A3	USB_P1	B3	USB_P2
A4	GND	B4	GND
A5	USB3_1RXN	4B	USB3_2RXN
A6	USB3_1RXP	B6	USB3_2RXP
A7	GND	B7	GND
A8	USB3_1TXN	B8	USB3_2TXN
A9	USB3_1TXP	B9	USB3_2TXP

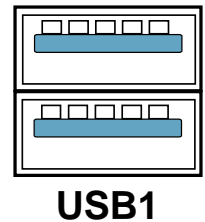

USB2: Universal Serial Bus Connector

The pin assignments are as follows:

PIN	ASSIGNMENT	PIN	ASSIGNMENT
A1	USB_VCC5	B1	USB_VCC5
A2	USB_N1	B2	USB_N2
A3	USB_P1	B3	USB_P2
A4	GND	B4	GND
A5	USB3_1RXN	B5	USB3_2RXN
A6	USB3_1RXP	B6	USB3_2RXP
A7	GND	B7	GND
A8	USB3_1TXN	B8	USB3_2TXN
A9	USB3_1TXP	B9	USB3_2TXP

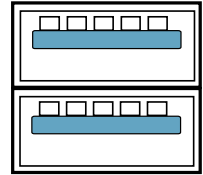

USB2

2-40. UNIVERSAL SERIAL BUS 2.0 CONNECTOR

USB4: Universal Serial Bus Connector

The pin assignments are as follows:

PIN	ASSIGNMENT
1	USB_VCC5
2	USB_VCC5
3	USB_N0
4	USB_N1
5	USB_P0
6	USB_P1
7	GND
8	GND
9	NC
10	GND

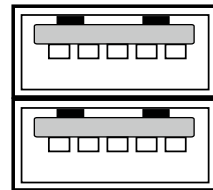

USB4

USB5: Universal Serial Bus Connector
 The pin assignments are as follows:

PIN	ASSIGNMENT
1	USB_VCC5
2	USB_VCC5
3	USB_N2
4	USB_N3
5	USB_P2
6	USB_P3
7	GND
8	GND
9	NC
10	GND

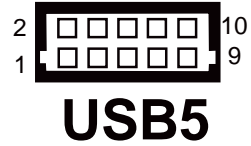

2-41. VGA Connector

VGA1: VGA Connector
 The pin assignments are as follows:

PIN	ASSIGNMENT
1	CRT_RED
2	CRT_GREEN
3	CRT_BLUE
4	NC
5	GND
6	NC
7	GND
8	GND
9	CRT_VCC
10	GND
11	NC
12	CRT_DATA
13	CRT_HSYNC
14	CRT_VSYNC
15	CRT_CLK

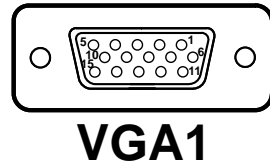

SOFTWARE UTILITIES

CHAPTER **3**

This chapter comprises the detailed information of VGA driver, LAN driver, and Sound driver.

Section includes:

- Introduction
- Intel® Chipset Software Installation Utility
- VGA Driver Utility
- LAN Driver Utility
- SOUND Driver Utility

3-1. INTRODUCTION

Enclosed with our SE-8210 package, you will find a CD ROM disk containing all types of drivers we have. As a SE-8210 user, you will only need some of files contained in the CD ROM disk, please take note of the following chart:

FILE NAME (Assume that CD ROM drive is D:)	PURPOSE
D:\Driver\UTILITY	Intel® Chipset Device Software Installation Utility
D:\Driver\VGA	Intel® HD Graphics Family For VGA driver installation
D:\Driver\LAN	Intel® 82574 For LAN Driver installation
D:\Driver\SOUND	Realtek High Definition Audio For Sound driver installation
D:\Driver\USB	Intel® 7 Series/C216 Chipset Family
D:\Driver\ME	Intel® 7 Series/C216 Chipset Family

Note: Be sure to install the Utility right after the OS is fully installed.

3-2. INTEL® CHIPSET SOFTWARE INSTALLATION UTILITY

3-2-1. Introduction

The Intel® Chipset Device Software installs Windows *.INF files to the target system. These files outline to the operating system how to configure the Intel® chipset components in order to ensure that the following features function properly:

- PCIe Support
- SATA Storage Support
- USB Support
- Identification of Intel® Chipset Components in the Device Manager

3-2-2. Installation of Utility for Windows XP/7/8.1

The Utility Pack is made only for Windows XP/7/8.1. It should be installed right after the OS installation; kindly follow the following steps:

1. Place insert the Utility Disk into Floppy Disk Drive A/B or CD ROM drive.
2. Under Windows system, go to the directory where Utility Disc is located.
e.g.: \DRIVER\UTILITY\infinst_autol.exe
3. Click infinst_autol.exe file for utility installation.
4. Follow the instructions on the screen to complete the installation.
5. Once installation is completed, shut down the system and restart in order for the changes to take effect.

3-3. VGA DRIVER UTILITY

The VGA interface is embedded with our SE-8210 system to support CRT display. The following illustration briefly shows you the content of VGA driver in D:\Driver\VGA.

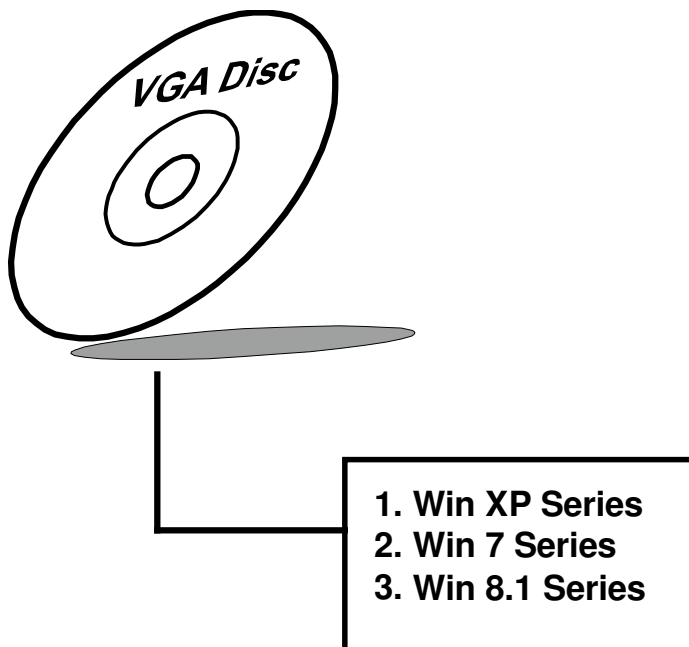

3-3-1. Installation of VGA Driver

1. Start the computer (Win XP/7).
2. Insert the Utility Disk into the CD ROM drive or drive A/B.
3. Open the VGA folder for your system to choose an appropriate folder, and double-click "exe" file to install. e.g. d:\DRIVER\VGA\Your system***.exe (If D is not your CD-ROM drive, substitute D with the correct drive letter.)
4. Follow the Wizard's on-screen instructions to complete the installation.

3-4. LAN DRIVER UTILITY

3-4-1. Introduction

The SE-8210 is enhanced with LAN function that can support various network adapters. The content of the LAN driver is found as follows:

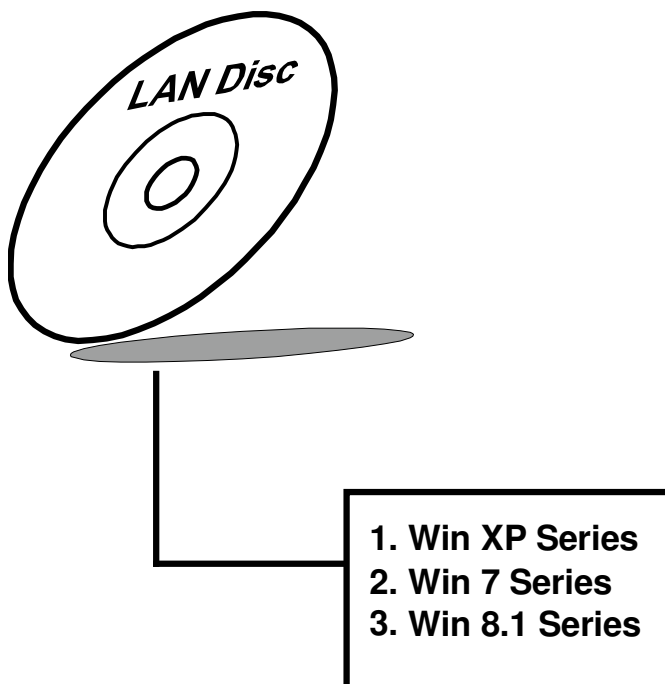

For more details on Installation procedure, please refer to Readme.txt file found on LAN DRIVER UTILITY.

3-5. SOUND DRIVER UTILITY

3-5-1. Introduction

The Audio chip enhanced in this system is fully compatible with Windows XP/7/8.1. Below, you will find the content of the Sound driver:

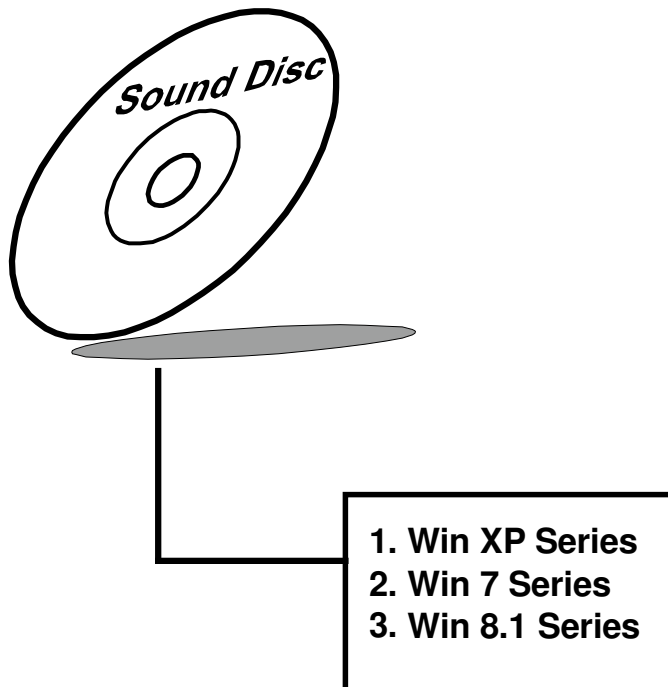

3-5-2. Installation Procedure for Windows XP/7/8.1

1. Open the SOUND folder. For your system to choose an appropriate folder, and Run the setup.exe program to start the installation. e.g. : \DRIVER\SOUND\Your system\setup.exe
2. (If D is not your CD-ROM drive, substitute D with the correct drive letter.)
3. Click on [Next] to continue the procedure. If the Windows popup "Windows can't verify the publisher of this driver software" message, press "Install this driver software anyway" to continue the installation.
4. Finally, select to restart the system and press [Finish] to complete the installation.

AMI BIOS SETUP

CHAPTER

4

This chapter shows how to set up the AMI BIOS.

Section includes:

- Introduction
- Entering Setup
- Main
- Advanced
- Chipset
- Boot
- Security
- Save & Exit

4-1. INTRODUCTION

The system SB-8210 uses an AMI Aptio BIOS that is stored in the Serial Peripheral Interface Flash Memory (SPI Flash) and can be updated. The SPI Flash contains the BIOS Setup program, Power-on Self-Test (POST), the PCI auto-configuration utility, LAN EEPROM information, and Plug and Play support.

Aptio is AMI’s BIOS firmware based on the UEFI (Unified Extensible Firmware Interface) Specifications and the Intel Platform Innovation Framework for EFI. The UEFI specification defines an interface between an operating system and platform firmware. The interface consists of data tables that contain platform-related information, boot service calls, and runtime service calls that are available to the operating system and its loader. These provide standard environment for booting an operating system and running pre-boot applications.

Following illustration shows Extensible Firmware Interface’s position in the software stack.

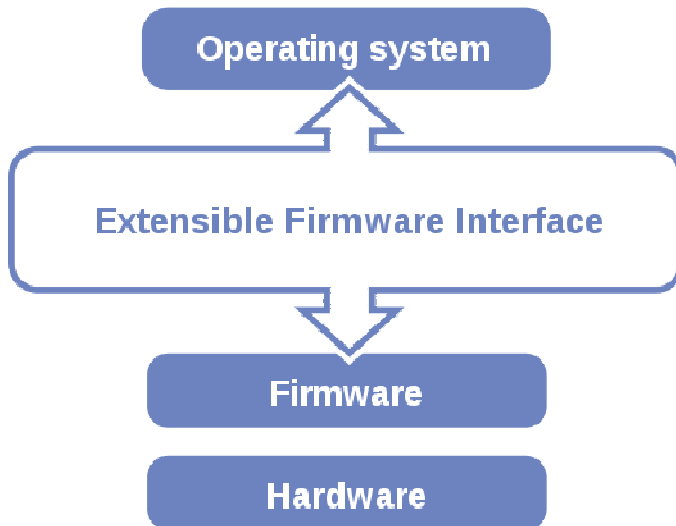

EFI BIOS provides an user interface allow users the ability to modify hardware configuration, e.g. change system date and time, enable or disable a system component, decide bootable device priorities, setup personal password, etc., which is convenient for modifications and customization of the computer system and allows technicians another method for finding solutions if hardware has any problems.

The BIOS Setup program can be used to view and change the BIOS settings for the computer. The BIOS Setup program is accessed by pressing the or <F2> key after the POST memory test begins and before the operating system boot begins. The settings are shown below.

4-2. ENTERING SETUP

When the system is powered on, the BIOS will enter the Power-On Self Test (POST) routines and the following message will appear on the lower screen:



POST screen

As long as this message is present on the screen you may press the key (the one that shares the decimal point at the bottom of the number keypad) to access the Setup program. In a moment, the main menu of the Aptio Setup Utility will appear on the screen:

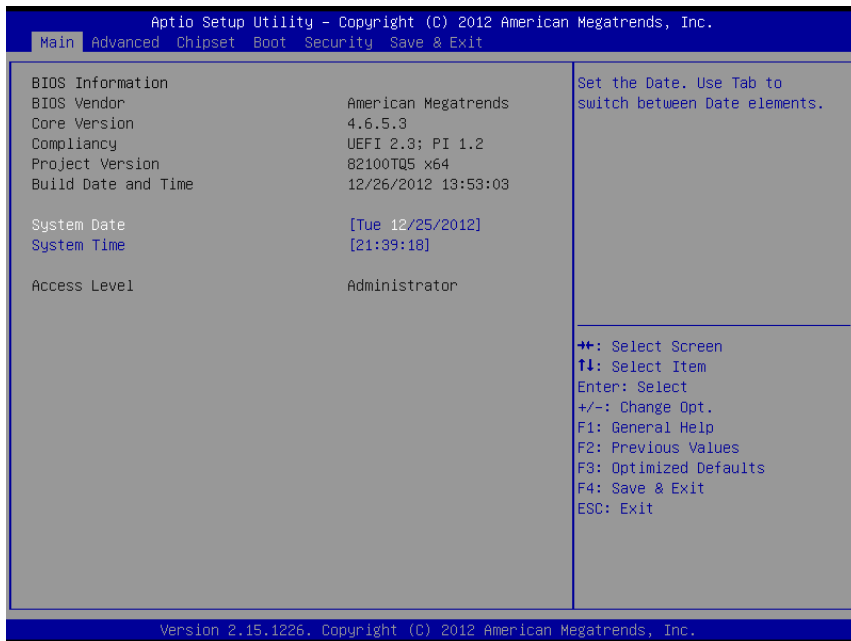

Setup program initial screen

You may move the cursor by up/down keys to highlight the individual menu items. As you highlight each item, a brief description of the highlighted selection will appear at the bottom of the screen.

4-3. Main

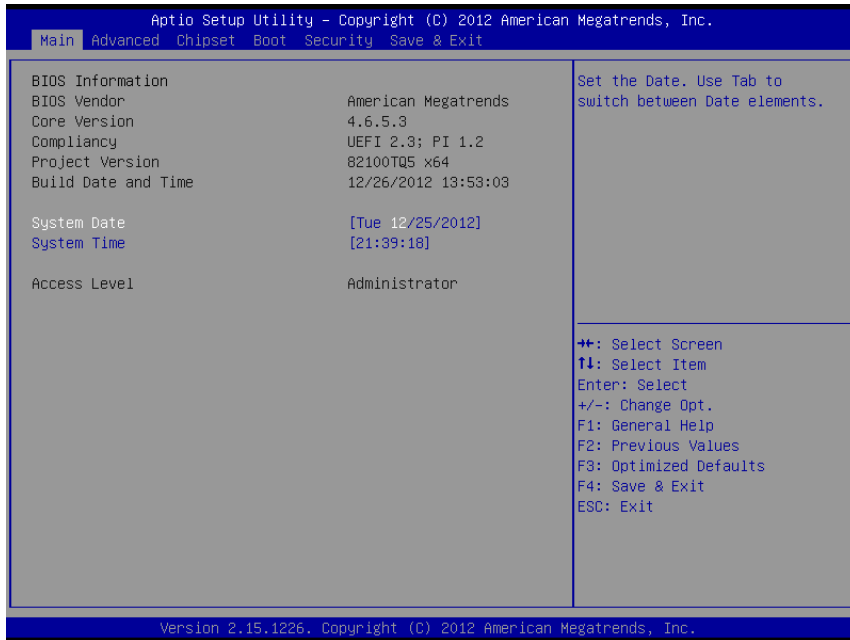

Main Screen

BIOS Setting	Options	Description/Purpose
BIOS Vendor	No changeable options	Displays the BIOS vendor.
Core Version	No changeable options	Displays the current BIOS core version.
Project Version	No changeable options	Displays the version of the BIOS currently installed on the platform.
Build Date	No changeable options	Displays the date of current BIOS version.
System Date	month, day, year	Specifies the current date.
System Time	hour, minute, second	Specifies the current time.

4-4. Advanced

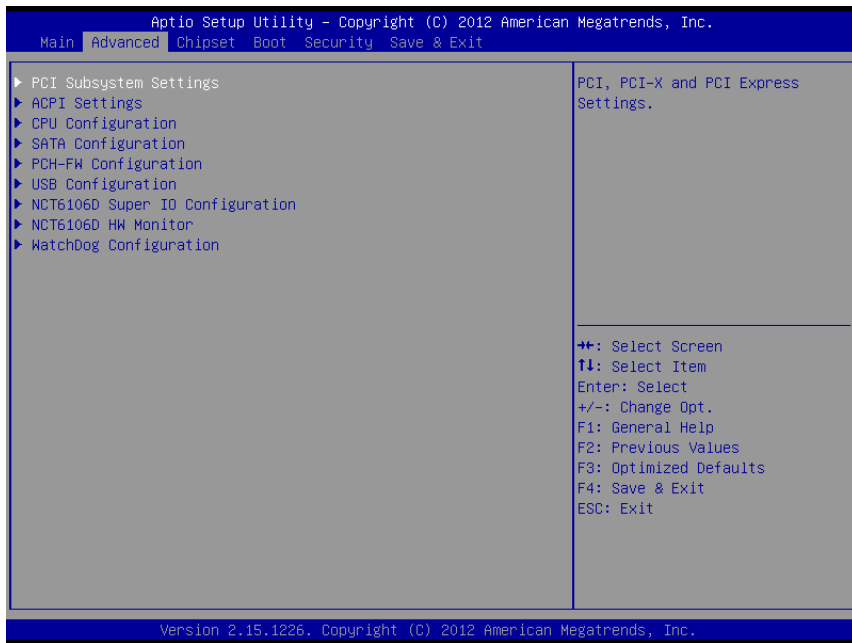

Advanced Screen

4-4-1. Advanced – PCI Subsystems Settings



PCI Subsystems Settings Screen

BIOS Setting	Options	Description/Purpose
PCI Latency Timer	-32 PCI Bus Clocks -64 PCI Bus Clocks -96 PCI Bus Clocks -128 PCI Bus Clocks -160 PCI Bus Clocks -192 PCI Bus Clocks -224 PCI Bus Clocks -248 PCI Bus Clocks	Sets PCI latency time.
VGA Palette Snoop	-Disabled -Enabled	Some non-standard VGA cards or MPEG video cards may not show colors properly. Setting this function to Enabled can correct this problem.

BIOS Setting	Options	Description/Purpose
PERR# Generation	-Disabled -Enabled	Enables or Disables PCI Device to Generate PERR#.
SERR# Generation	-Disabled -Enabled	Enables or Disables PCI Device to Generate SERR#.

4-4-2. Advanced - ACPI Settings

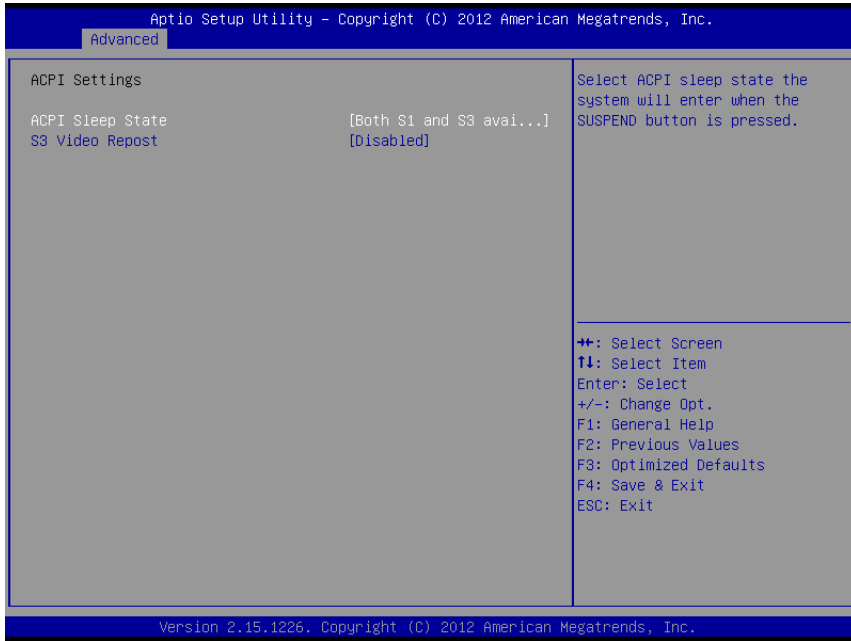

ACPI Settings Screen

BIOS Setting	Options	Description/Purpose
ACPI Sleep State	-Suspend Disabled -S1 only(CPU Stop Clock) -S3 only(Suspend to RAM) -Both S1 and S3 available for OS to choose from	Select the highest ACPI sleep state the system will enter, when the SUSPEND button is pressed.
S3 Video Report	-Disabled -Enabled	Set this value to allow video report support.

4-4-3. Advanced - CPU Configuration

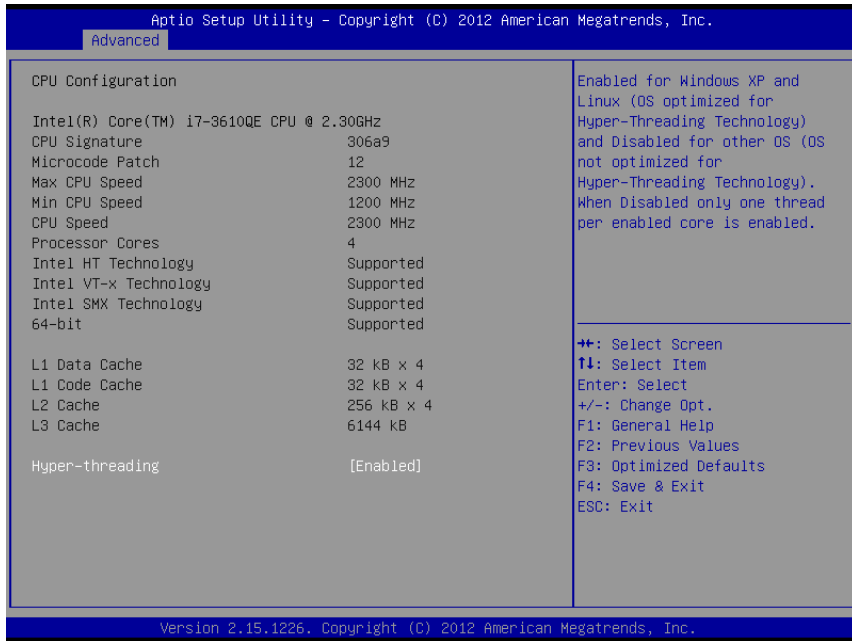

CPU Configuration Screen

BIOS Setting	Options	Description/Purpose
CPU Signature	no changeable options	CPU Signature
Microcode Patch	no changeable options	Microcode Patch
Max CPU Speed	no changeable options	Max CPU Speed
Min CPU Speed	no changeable options	Min CPU Speed
CPU speed	no changeable options	CPU speed
Processor Cores	no changeable options	Processor Cores
Intel HT Technology	no changeable options	Intel HT Technology
Intel VT-x Technology	no changeable options	Intel VT-x Technology
Intel SMX Technology	no changeable options	Intel SMX Technology
64-bit	no changeable options	Reports if processor supports Intel x86-

BIOS Setting	Options	Description/Purpose
		64
L1 Data Cache	no changeable options	L1 Data Cache
L1 Code Cache	no changeable options	L1 Code Cache
L2 Cache	no changeable options	L2 Cache
L3 Cache	no changeable options	L3 Cache
Hyper-Threading	-Disabled -Enabled	Enabled for Windows XP and Linux (OS optimized for Hyper-Threading Technology) and Disabled for other OS (OS not optimized for Hyper-Threading Technology). When Disabled, only one thread per enabled core is enabled.

4-4-4. Advanced – SATA Configuration

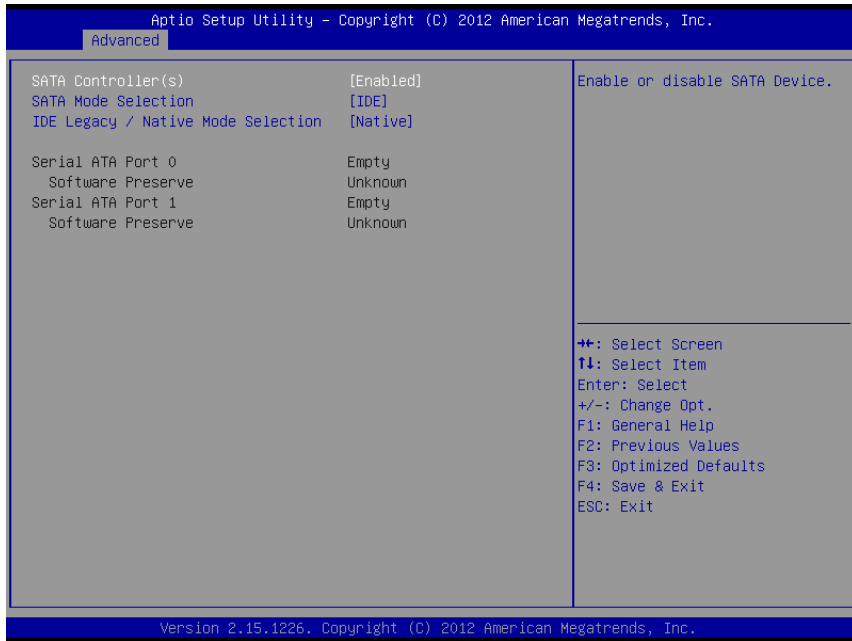

SATA Configuration Screen

BIOS Setting	Options	Description/Purpose
SATA Controller(s)	-Disabled -Enabled	Enable / Disable Serial ATA Controller.
SATA Mode Selection	-IDE -AHCI -RAID	SATA controller type selection, corresponding to three options: IDE, RAID and AHCI.
IDE Legacy / Native Mode Selection	-Native -Legacy	IDE mode selection
Serial ATA Port0	[drive]	Displays the drive installed on this SATA port. Shows [Empty] if no drive is installed.
Serial ATA Port1	[drive]	Displays the drive installed on this SATA port. Shows [Empty] if no drive

BIOS Setting	Options	Description/Purpose
		is installed.

4-4-5. PCH-FW Configuration

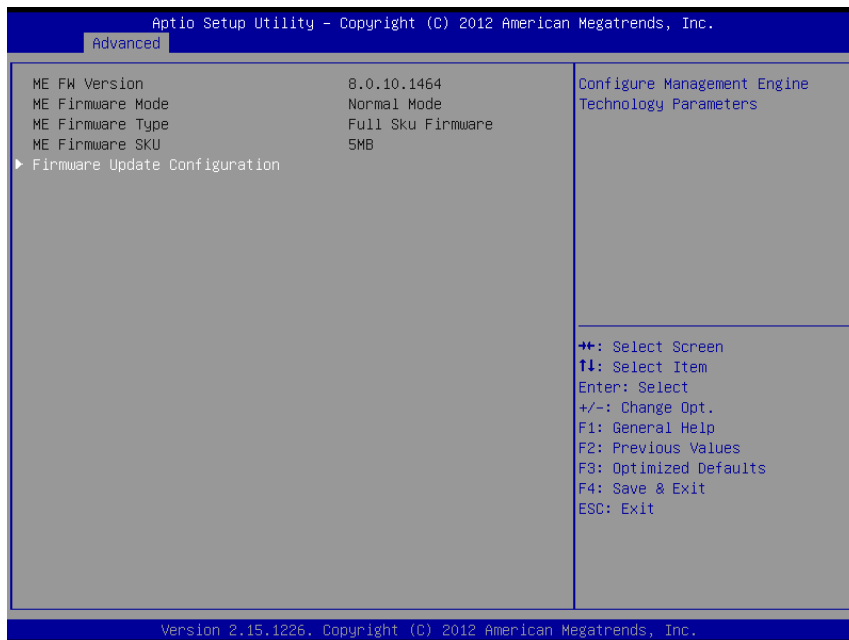

PCH-FW Configuration Screen

BIOS Setting	Options	Description/Purpose
ME FW Version	no changeable options	ME FW Version
ME Firmware Mode	no changeable options	ME Firmware Mode
ME Firmware Type	no changeable options	ME Firmware Type
ME Firmware SKU	no changeable options	ME Firmware SKU

4-4-5-1. PCH-FW Configuration – Firmware Update Configuration



PCH-FW Configuration – Firmware Update Configuration Screen

BIOS Setting	Options	Description/Purpose
ME FW Image Re-Flash	-Disabled -Enabled	Use this item to enable or disable ME FW Image Re-Flash function.

4-4-6. Advanced – USB Configuration

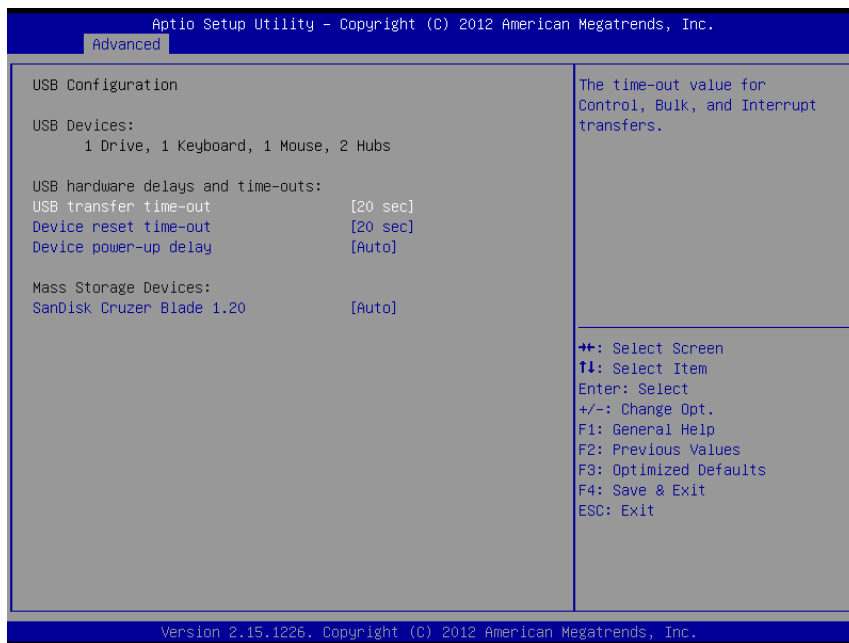

USB Configuration Screen

BIOS Setting	Options	Description/Purpose
USB Transfer time-out	-1 sec -5 sec -10 sec -20 sec	Use this item to set the time-out value for control, bulk, and interrupt transfers.
Device reset time-out	-10 sec -20 sec -30 sec -40 sec	Use this item to set USB mass storage device start unit command time-out.
Device power-up delay	-Auto -Manual	Use this item to set maximum time the device will take before it properly reports

4-4-7. Advanced – NCT6106 Super IO Configuration

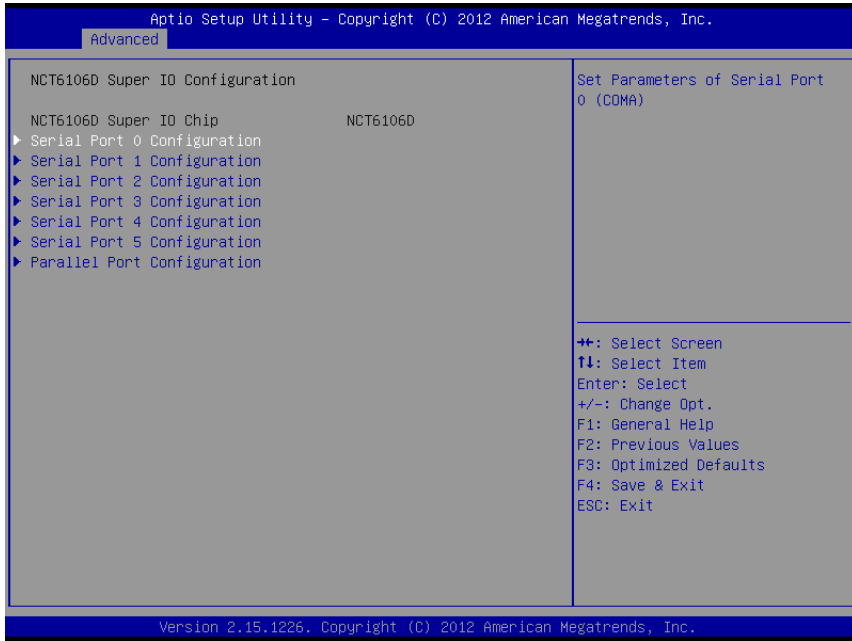

NCT6106 Super IO Configuration Screen

BIOS Setting	Options	Description/Purpose
Super IO Chip	No changeable options	Displays the super IO chip model.

4-4-7-1. Advanced – NCT6106 Super IO Configuration – Serial Port 0 Configuration

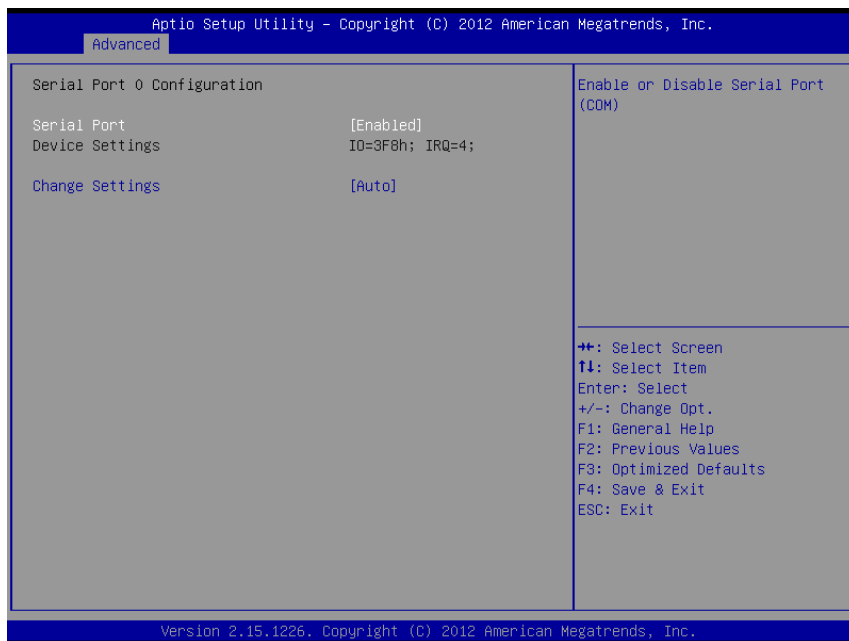

NCT6106 Super IO Configuration - Serial Port 0 Configuration Screen

BIOS Setting	Options	Description/Purpose
Serial Port	-Disabled -Enabled	Configures the serial port 0.
Device Settings	No changeable options	Reports the current serial port 0 setting.
Change Settings	-Auto -IO=3F8h; IRQ=4 -IO=3F8h; IRQ=3,4,5,6,7,10,11,12 -IO=2F8h; IRQ=3,4,5,6,7,10,11,12 -IO=3E8h; IRQ=3,4,5,6,7,10,11,12 -IO=2E8h;	Specifies the base I/O address and interrupt request for the serial port 0 if enabled.

BIOS Setting	Options	Description/Purpose
	IRQ=3,4,5,6,7,10,11,12	

4-4-7-2. Advanced – NCT6106 Super IO Configuration – Serial Port 1 Configuration



NCT6106 Super IO Configuration - Serial Port 1 Configuration Screen

BIOS Setting	Options	Description/Purpose
Serial Port	-Disabled -Enabled	Configures the serial port 1.
Device Settings	No changeable options	Reports the current serial port 1 setting.
Change Settings	-Auto -IO=2F8h; IRQ=3 -IO=3F8h; IRQ=3,4,5,6,7,10,11,12 -IO=2F8h; IRQ=3,4,5,6,7,10,11,12 -IO=3E8h; IRQ=3,4,5,6,7,10,11,12 -IO=2E8h;	Specifies the base I/O address and interrupt request for the serial port 1 if enabled.

BIOS Setting	Options	Description/Purpose
	IRQ=3,4,5,6,7,10,11,12	

4-4-7-3. Advanced – NCT6106 Super IO Configuration – Serial Port 2 Configuration

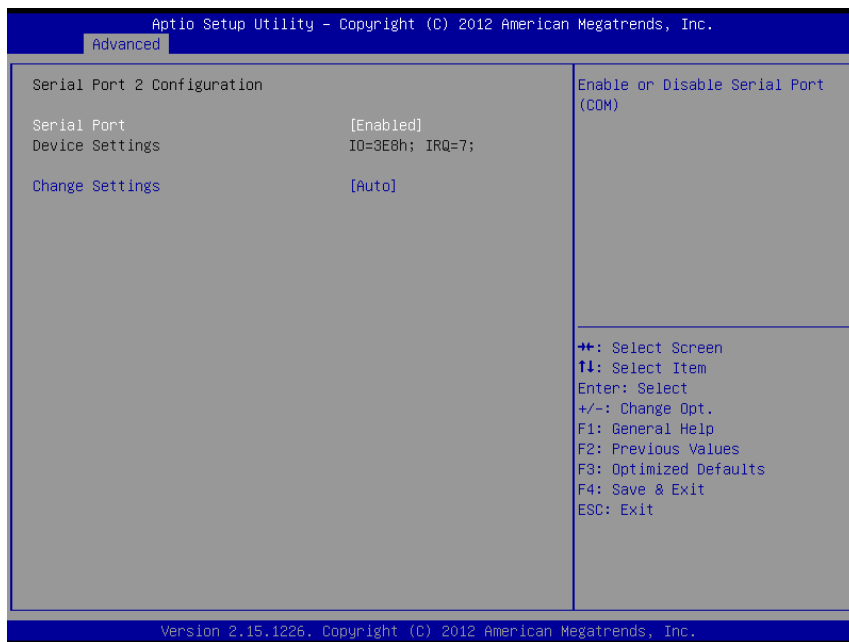

NCT6106 Super IO Configuration - Serial Port 2 Configuration Screen

BIOS Setting	Options	Description/Purpose
Serial Port	-Disabled -Enabled	Configures the serial port 2.
Device Settings	No changeable options	Reports the current serial port 2 setting.
Change Settings	-Auto -IO=3E8h; IRQ=7 -IO=3E8h; IRQ=3,4,5,6,7,10,11,12 -IO=2E8h; IRQ=3,4,5,6,7,10,11,12 -IO=2E0h; IRQ=3,4,5,6,7,10,11,12 -IO=2F0h;	Specifies the base I/O address and interrupt request for the serial port 2 if enabled.

BIOS Setting	Options	Description/Purpose
	IRQ=3,4,5,6,7,10,11,12	

4-4-7-4. Advanced – NCT6106 Super IO Configuration – Serial Port 3 Configuration

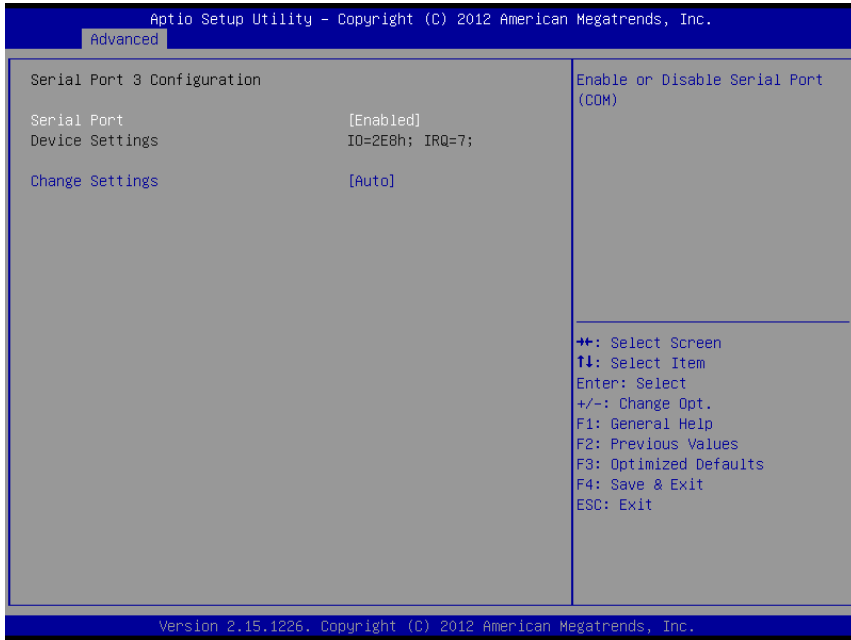

NCT6106 Super IO Configuration - Serial Port 3 Configuration Screen

BIOS Setting	Options	Description/Purpose
Serial Port	-Disabled -Enabled	Configures the serial port 3.
Device Settings	No changeable options	Reports the current serial port 3 setting.
Change Settings	-Auto -IO=2E8h; IRQ=7 -IO=3E8h; IRQ=3,4,5,6,7,10,11,12 -IO=2E8h; IRQ=3,4,5,6,7,10,11,12 -IO=2E0h; IRQ=3,4,5,6,7,10,11,12 -IO=2F0h;	Specifies the base I/O address and interrupt request for the serial port 3 if enabled.

BIOS Setting	Options	Description/Purpose
	IRQ=3,4,5,6,7,10,11,12	

4-4-7-5. Advanced – NCT6106 Super IO Configuration – Serial Port 4 Configuration

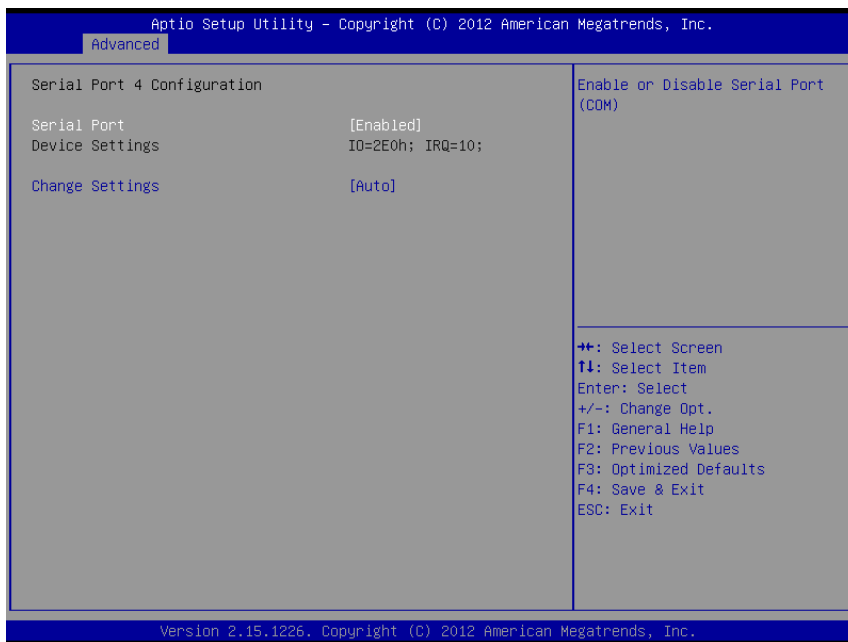

NCT6106 Super IO Configuration - Serial Port 4 Configuration Screen

BIOS Setting	Options	Description/Purpose
Serial Port	-Disabled -Enabled	Configures the serial port 4.
Device Settings	No changeable options	Reports the current serial port 4 setting.
Change Settings	-Auto -IO=2E0h; IRQ=10 -IO=3E8h; IRQ=3,4,5,6,7,10,11,12 -IO=2E8h; IRQ=3,4,5,6,7,10,11,12 -IO=2E0h; IRQ=3,4,5,6,7,10,11,12 -IO=2F0h;	Specifies the base I/O address and interrupt request for the serial port 4 if enabled.

BIOS Setting	Options	Description/Purpose
	IRQ=3,4,5,6,7,10,11,12	

4-4-7-6. Advanced – NCT6106 Super IO Configuration – Serial Port 5 Configuration

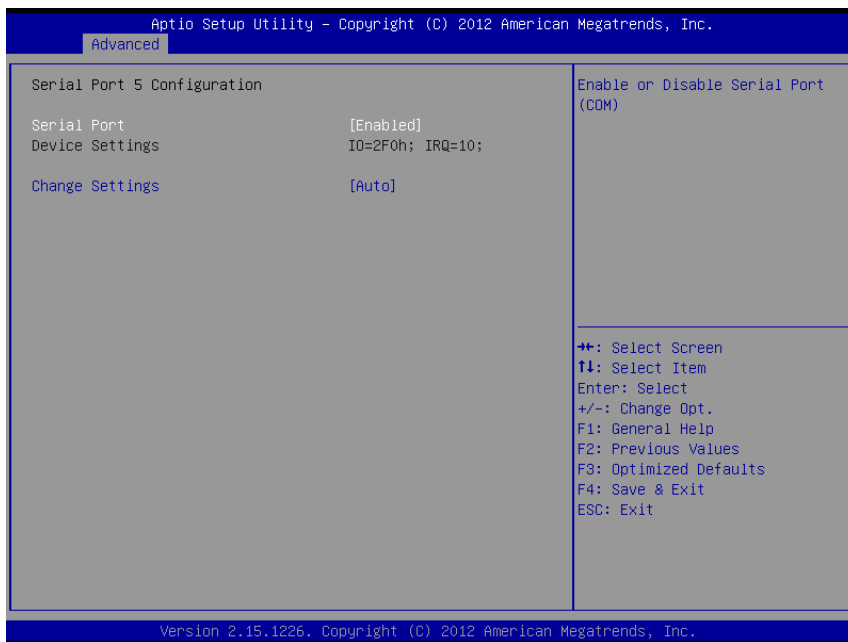

NCT6106 Super IO Configuration - Serial Port 5 Configuration Screen

BIOS Setting	Options	Description/Purpose
Serial Port	-Disabled -Enabled	Configures the serial port 5.
Device Settings	No changeable options	Reports the current serial port 5 setting.
Change Settings	-Auto -IO=2F0h; IRQ=10 -IO=3E8h; IRQ=3,4,5,6,7,10,11,12 -IO=2E8h; IRQ=3,4,5,6,7,10,11,12 -IO=2E0h; IRQ=3,4,5,6,7,10,11,12 -IO=2F0h;	Specifies the base I/O address and interrupt request for the serial port 5 if enabled.

BIOS Setting	Options	Description/Purpose
	IRQ=3,4,5,6,7,10,11,12	

4-4-7-7. Advanced – NCT6106 Super IO Configuration – Parallel Port Configuration



NCT6106 Super IO Configuration - Parallel Port Configuration Screen

BIOS Setting	Options	Description/Purpose
Parallel Port	-Disabled -Enabled	Configures the parallel port.
Change Settings	-Auto -IO=378h; IRQ=5 -IO=378h; IRQ=5,6,7,10,11,12 -IO=278h; IRQ=5,6,7,10,11,12 -IO=3BCh; IRQ=5,6,7,10,11,12	Specifies the base I/O address and interrupt request for the parallel port if enabled.
Device Mode	-STD Printer Mode -SPP Mode	Selects the mode for the parallel port. Not available if the parallel port is

BIOS Setting	Options	Description/Purpose
	-EPP-1.9 and SPP Mode -EPP-1.7 and SPP Mode -ECP -ECP and EPP 1.9 Mode -ECP and EPP 1.7 Mode	disabled. SPP is Standard Parallel Port mode, a bi-directional mode for printers. EPP is Enhanced Parallel Port mode, a high-speed bi-directional mode for non-printer peripherals. ECP is Enhanced Capability Port mode, a high-speed bi-directional mode for printers and scanners.

4-4-8. Advanced – NCT6106 HW Monitor

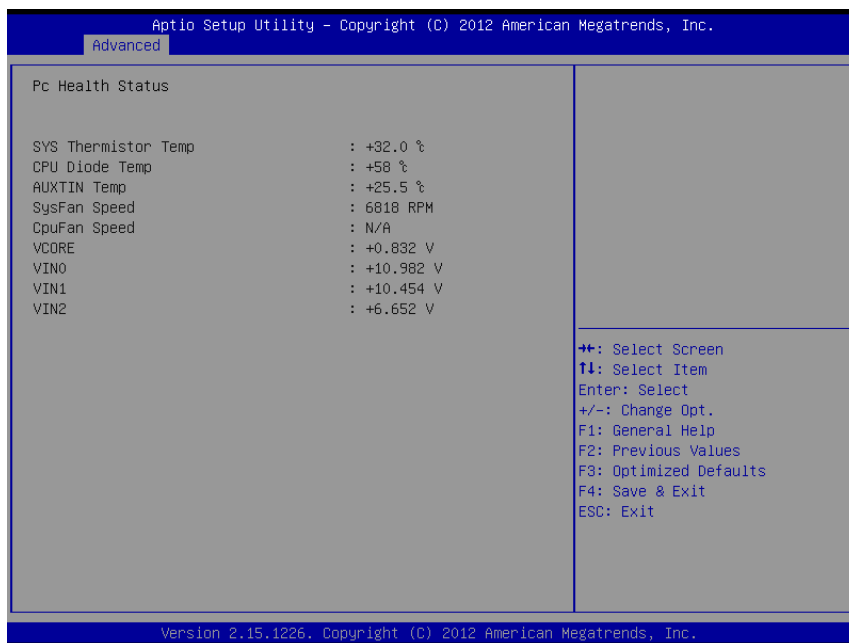

H/W Monitor Screen

BIOS Setting	Options	Description/Purpose
SYS Thermistor Temp	No changeable options	Display system temperature.
CPU Diode Temp	No changeable options	Display processor's temperature.
SysFan Speed	No changeable options	Display fan speed of the System fan.
CpuFan Speed	No changeable options	Display fan speed of the CPU fan.
VCORE	No changeable options	Display voltage level of the +VCORE in supply.
VIN0	No changeable options	Display voltage level of the VIN0 in supply.
VIN1	No changeable options	Display voltage level of the VIN0 in supply.
VIN2	No changeable options	Display voltage level of the VIN2 in supply.

4-4-9. Advanced – WatchDog Configuration

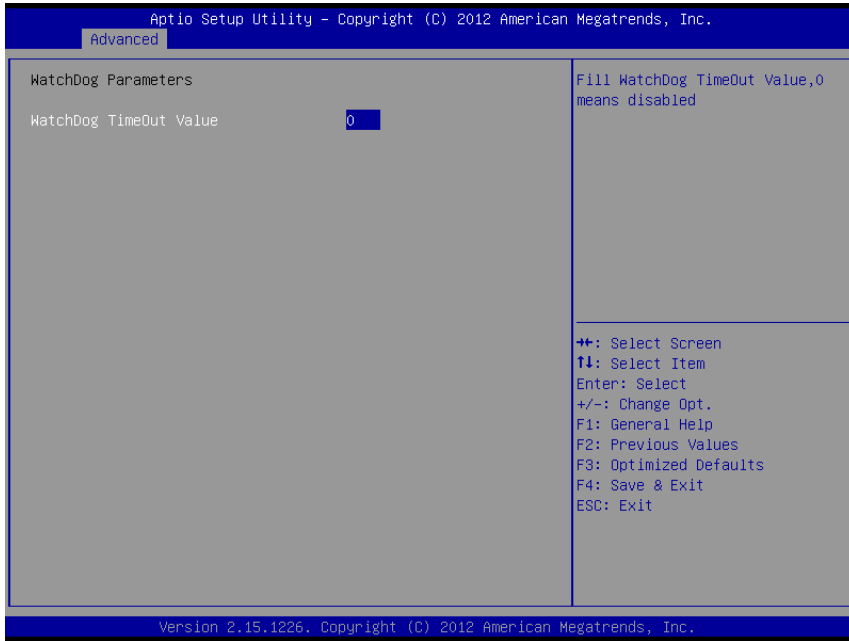

Watchdog Configuration Screen

BIOS Setting	Options	Description/Purpose
Watchdog timeout value	multiple options ranging from 0 to 255	Sets the desired value for watchdog timer. 0 means disabled.

4-5. Chipset

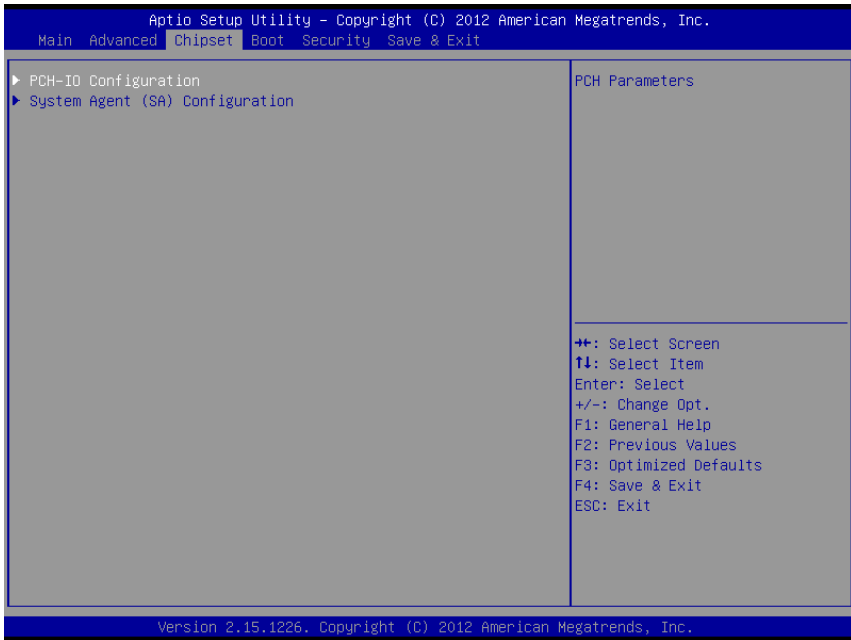

Chipset Screen

4-5-1. Chipset – PCH-IO Configuration

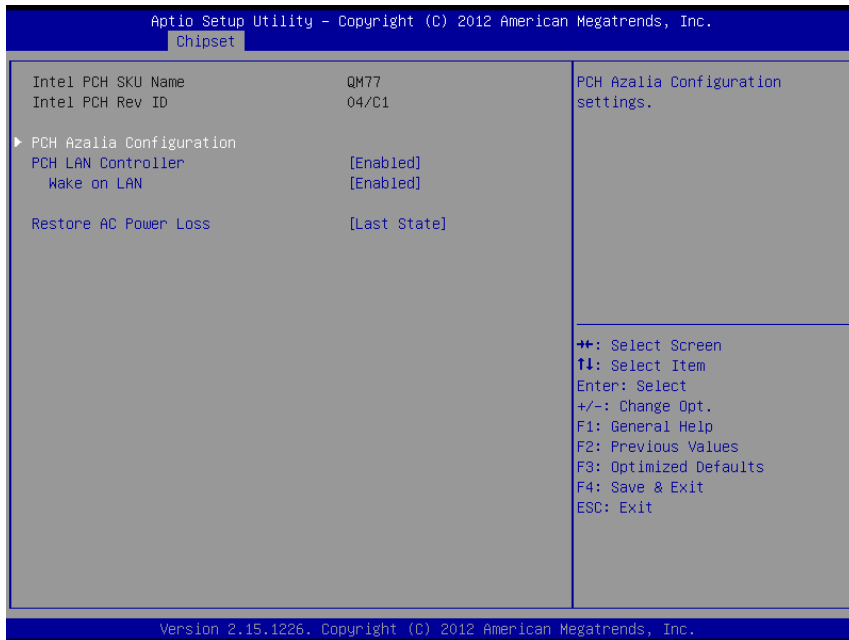

PCH-IO Configuration Screen

BIOS Setting	Options	Description/Purpose
Intel PCH SKU Name	No changeable options	Displays Intel PCH SKU Name.
Intel PCH Rev ID	No changeable options	Display Intel PCH Rev ID.
PCH LAN Controller	-Enabled -Disabled	Enable or disable onboard NIC.
Wake on LAN	-Enabled -Disabled	Enable or disable integrated LAN to wake the system.
Restore AC Power Loss	-Power Off -Power On -Last State	Use this item to select AC power state when power is re-applied after a power failure.

4-5-1-1. Chipset - PCH-IO Configuration – PCH Azalia Configuration

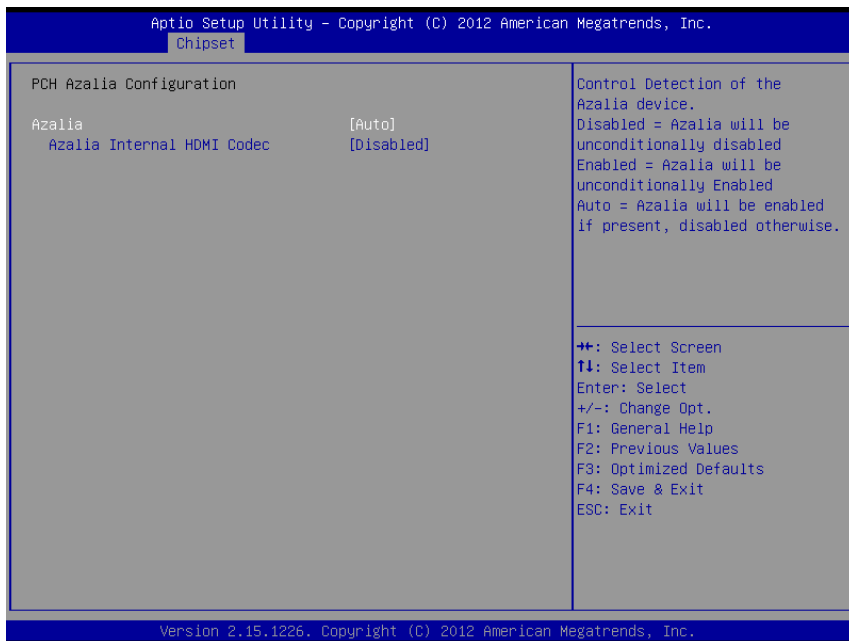

PCH-IO Configuration – PCH Azalia Configuration Screen

BIOS Setting	Options	Description/Purpose
Azalia	-Disabled -Enabled -Auto	The Audio Configuration settings Enable/Disable the Azalia HD Audio.
Azalia Internal HDMI Codec	-Disabled -Enabled	Use this item to enable or disable internal HDMI codec for Azalia.

4-5-2. Chipset – System Agent (SA) Configuration

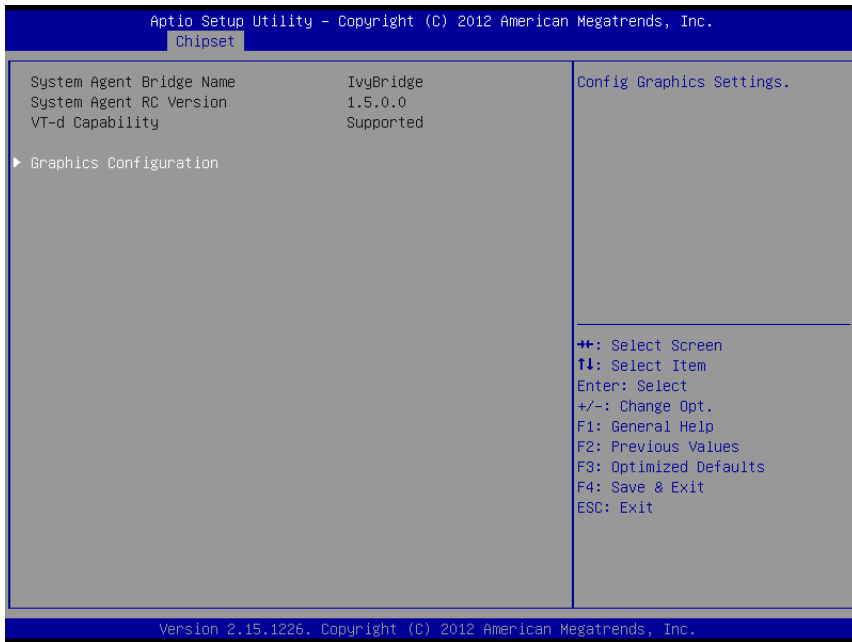

System Agent (SA) Configuration Screen

BIOS Setting	Options	Description/Purpose
System Agent Bridge Name	No changeable options	Displays System Agent Bridge Name.
System Agent RC Version	No changeable options	Display System Agent RC Version.
VT-d Capability	No changeable options	Display VT-d Capability.

4-5-2-1. Chipset – System Agent (SA) Configuration – Graphics Configuration

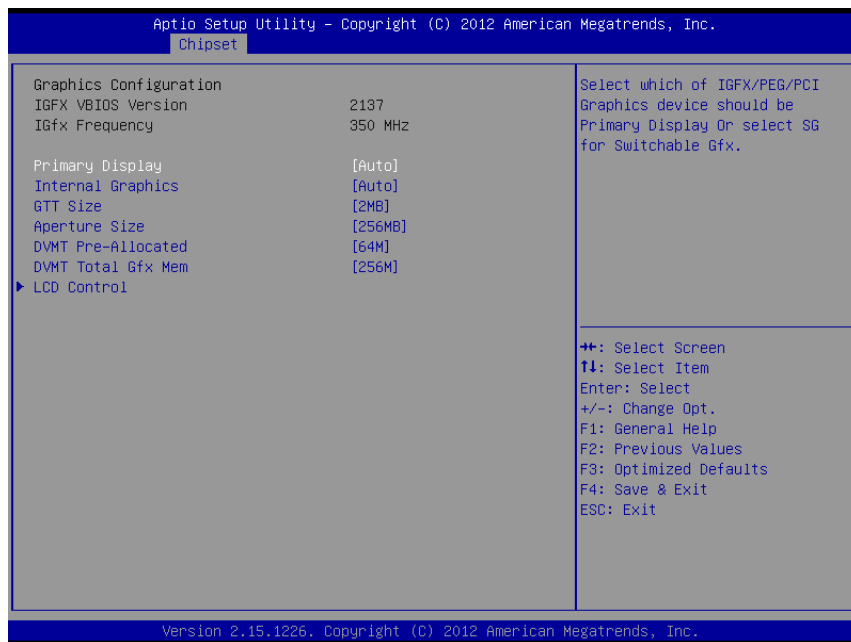

System Agent (SA) Configuration – Graphics Configuration Screen

BIOS Setting	Options	Description/Purpose
Primary Display	-Auto -IGFX -PEG -PCI -SG	Select which of IGFX/PEG/PCI graphics device should be primary display or select SG for switchable Gfx.
Internal Graphics	-Auto -Disabled -Enabled	Keep IGD enabled based on the setup options
GTT Size	-1MB -2MB	Select the GTT Size.
Aperture Size	-128MB -256MB	Select the Aperture Size.

BIOS Setting	Options	Description/Purpose
	-512MB	
DVMT Pre-Allocated	-32MB -64MB -96MB -128MB -160MB -192MB -224MB -256MB -288MB -320MB -352MB -384MB -416MB -448MB -480MB -512MB -1024MB	Select DVMT 5.0 Pre-Allocated (Fixed) graphics memory size used by the internal graphics device.
DVMT Total Gfx Mem	-128MB -256MB -MAX	Select DVMT 5.0 total graphics memory size used by the internal graphics device.

4-5-2-2. Chipset – System Agent (SA) Configuration – Graphics Configuration – LCD Control



System Agent (SA) Configuration – Graphics Configuration – LCD Control Screen

BIOS Setting	Options	Description/Purpose
Primary IGFX Boot Display	-VBIOS Default -CRT -EFP -LFP -EFP3 -EFP2 -LFP2	Select the Video Device, which will be activated during POST. This has no effect if external graphics present. Secondary boot display selection will appear based on your selection. VGA modes will be supported only on primary display.
LCD Panel Type	-VBIOS Default -640x480 LVDS -800x600 LVDS	Select LCD panel used by Internal Graphics Device by selecting the appropriate setup item.

BIOS Setting	Options	Description/Purpose
	-1024x768 LVDS1 -1280x1024 LVDS -1400x1050(RB) LVDS1 -1400x1050 LVDS2 -1600x1200 LVDS -1366x768 LVDS -1680x1050 LVDS -1920x1200 LVDS1 -1440x900 LVDS -1600x900 LVDS -1024x768 LVDS2 -1280x800 LVDS -1920x1080 LVDS -2048x1536 LVDS	
Active LFP	-No LVDS -Int-LVDS	Select the Active LFP Configuration. No LVDS: VBIOS does not enable LVDS. Int-LVDS: VBIOS enables LVDS driver by Integrated encoder. SDVO LVDS: VBIOS enables LVDS driver by SDVO encoder. eDP Port-A: LFP Driven by Int-DisplayPort encoder from Port-A.
Panel Color Depth	- 18 Bit - 24 Bit	Select the LFP Panel Color Depth.

4-6. Boot

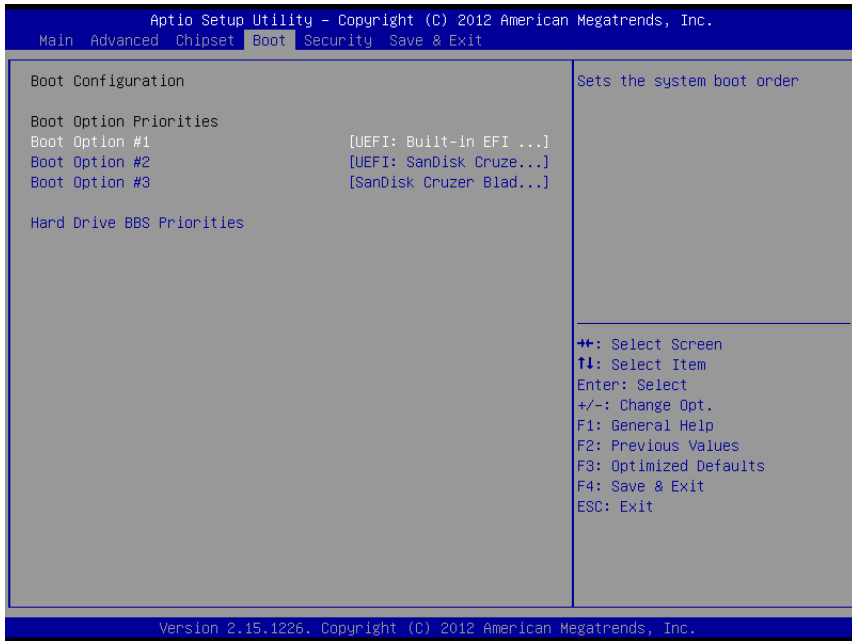

Boot Screen

BIOS Setting	Options	Description/Purpose
Boot Option #1	-[drive(s)] -Disabled	Allows to set boot option listed in Hard Drive BBS Priorities.

4-7. Security

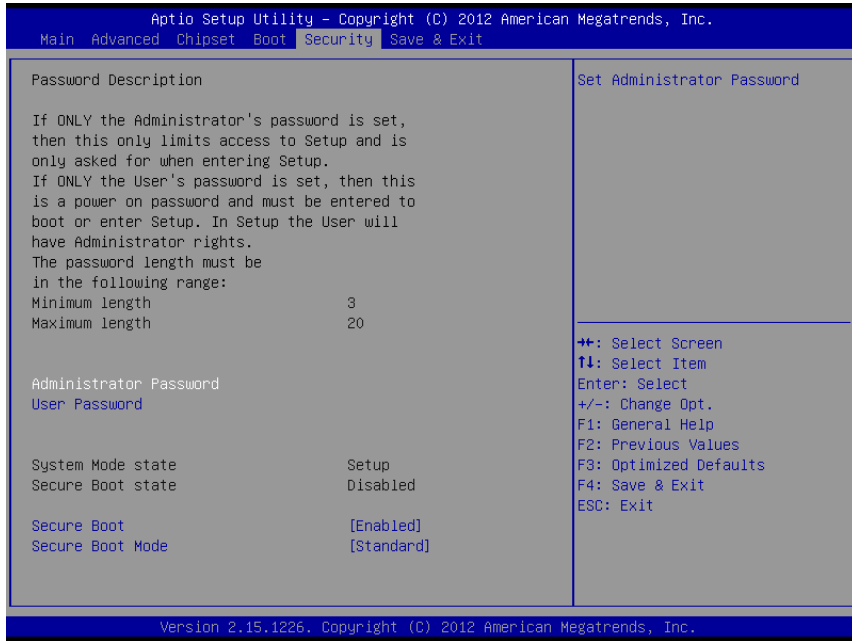

Security Screen

BIOS Setting	Options	Description/Purpose
Administrator Password	Password can be up to 20 alphanumeric characters.	Specifies the administrator password.
User Password	Password can be up to 20 alphanumeric characters.	Specifies the user password.

4-8. Save & Exit

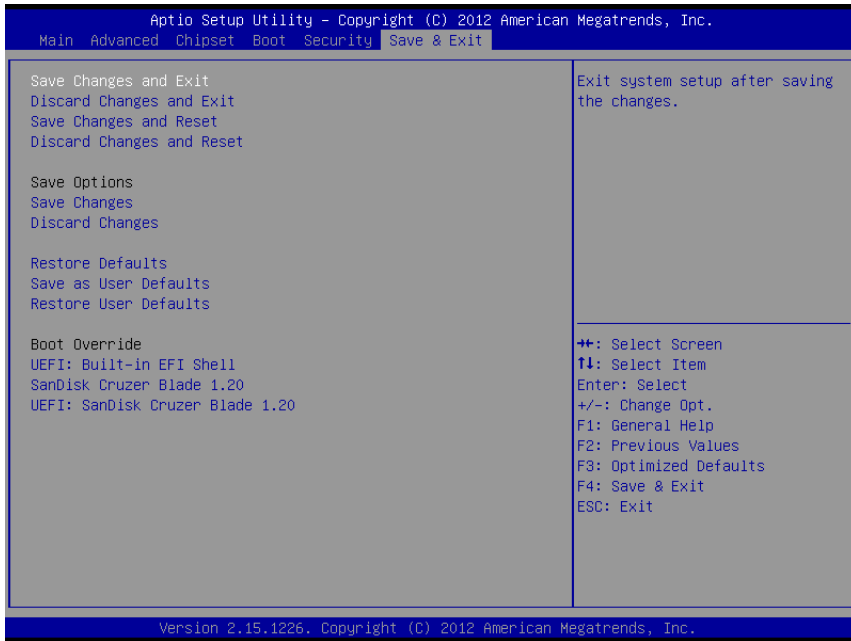

Save & Exit Screen

BIOS Setting	Options	Description/Purpose
Save Changes and Exit	No changeable options	Exits and saves the changes in CMOS SRAM.
Discard Changes and Exit	No changeable options	Exits without saving any changes made in BIOS settings.
Save Changes and Reset	No changeable options	Saves the changes in CMOS SRAM and resets.
Discard Changes and Reset	No changeable options	Resets without saving any changes made in BIOS settings.
Save Changes	No changeable options	Saves the changes done in BIOS settings so far.
Discard Changes	No changeable options	Discards the changes done in BIOS settings so far.
Restore Defaults	No changeable options	Loads the optimized defaults for BIOS

BIOS Setting	Options	Description/Purpose
		settings.
Save as User Defaults	No changeable options	Saves the current values as user defaults.
Restore User Defaults	No changeable options	Loads the user defaults for BIOS settings.
Boot Override	-[drive(s)]	Forces to boot from selected [drive(s)].

SYSTEM ASSEMBLY

APPENDIX

A

This appendix contains the exploded diagram of the system.

Section includes:

- Exploded Diagram for SE-8210 Whole System
- Exploded Diagram for SE-8210 Wall-mount Stand
- Exploded Diagram for SE-8210 Packing
- Exploded Diagram for Mini-PCIE Card
- Exploded Diagram for PCIE Card

EXPLODED DIAGRAM FOR SE-8210 WHOLE SYSTEM

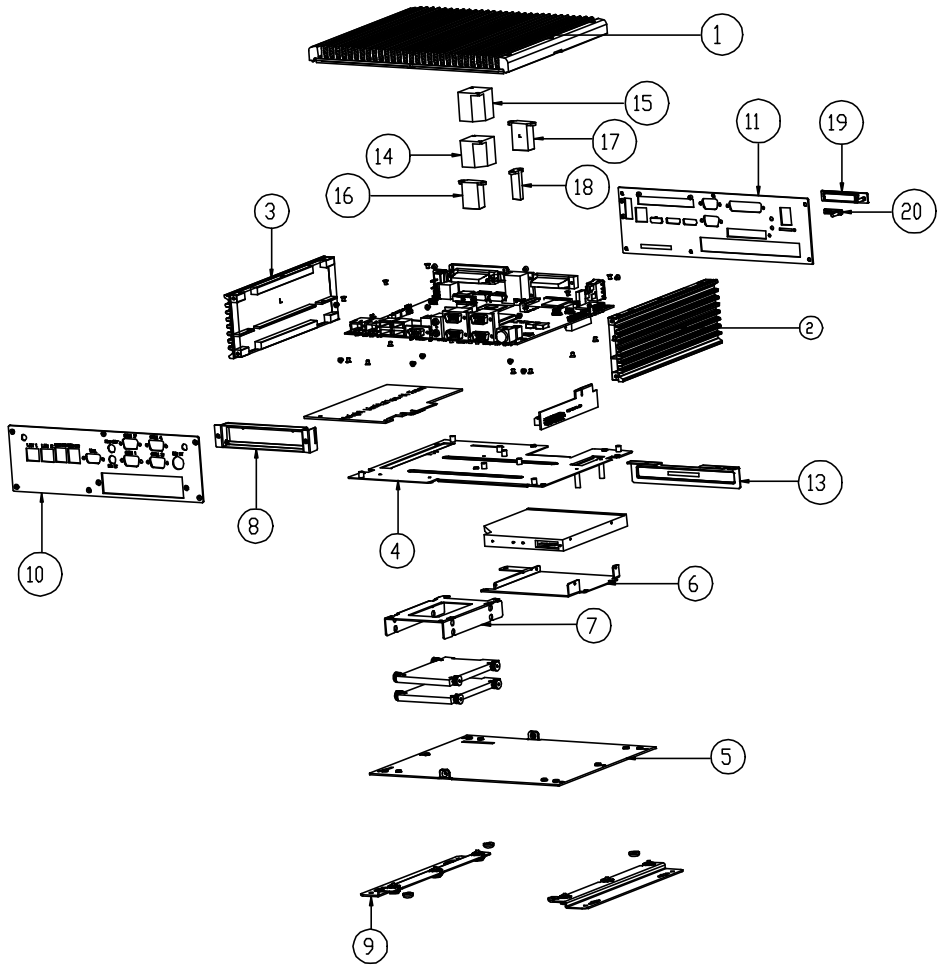

NO	Name	P/N	Q'ty	Remark
Matel(AL Extrude)				
1	Heatsink top cover	21-002-16000001	1	
2	Heatsink right cover	21-002-10071001	1	
3	Heatsink left cover	21-002-10071002	1	
Matel(Bracket)				
4	Base bracket	20-006-03001261	1	
5	Bottom bracket	20-006-03002261	1	
6	CDROM bracket	20-006-03003261	1	
7	HDD bracket	20-006-03004261	1	
8	Slot bracket	20-006-03005261	1	
9	Wallmount stand	20-017-03001261	2	For wall mount (Option)
10	Front ID bracket	20-006-01101261	1	
11	Rear ID bracket	20-006-01102261	1	
12	Rear ID DID bracket	20-006-01103261	1	Option
13	CDROM hole bracket	20-006-01091261	1	
Heatsink Bolck				
14	Heatsink block cpu	21-002-10000505	1	
15	Heatsink block southbridge	21-002-10000504	1	
16	Heatsink block inductor_h	21-002-10000502	1	
17	Heatsink block inductor_l	21-002-10000503	1	
18	Heatsink block controller	21-002-10000501	1	
Rubber				
19	Cfast rubber cover	30-013-01100261	1	
20	Simcard rubber cover	30-013-01200261	1	

EXPLODED DIAGRAM FOR WALL-MOUNT STAND

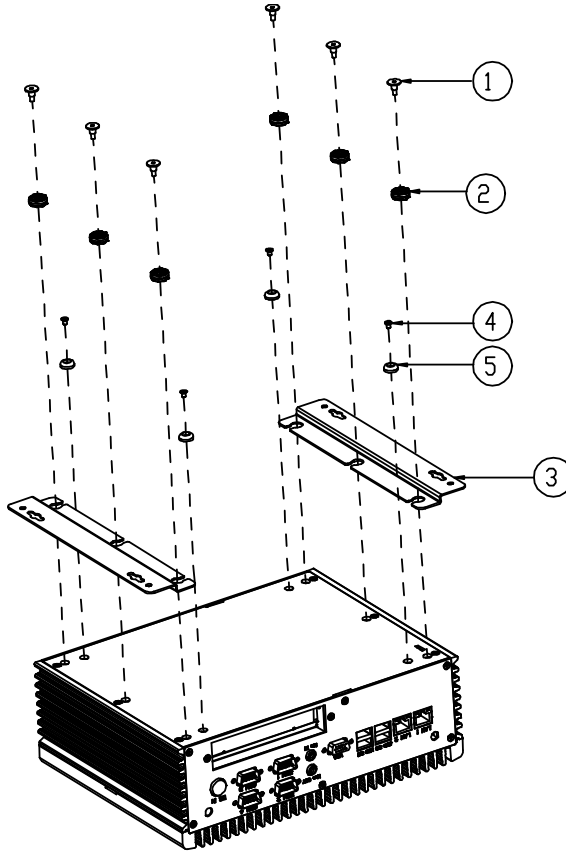

NO	Name	P/N	Q'ty	Remark
	Wall mount part			
1	FILLISTER HEAD SCREW M3x0.5Px4L,H=7.6mm	22-272-30128018	6	Option
2	Vibration Rubber	30-013-01100031	6	Option
3	Wallmount stand	20-017-03001261	2	Option
4	FLAT HEAD SCREW #2/#5/M3x0.5Px6mm(Black)	22-215-30006311	4	
5	Rubber Foot	90-004-01400000	4	

EXPLODED DIAGRAM FOR SE-8210 PACKING

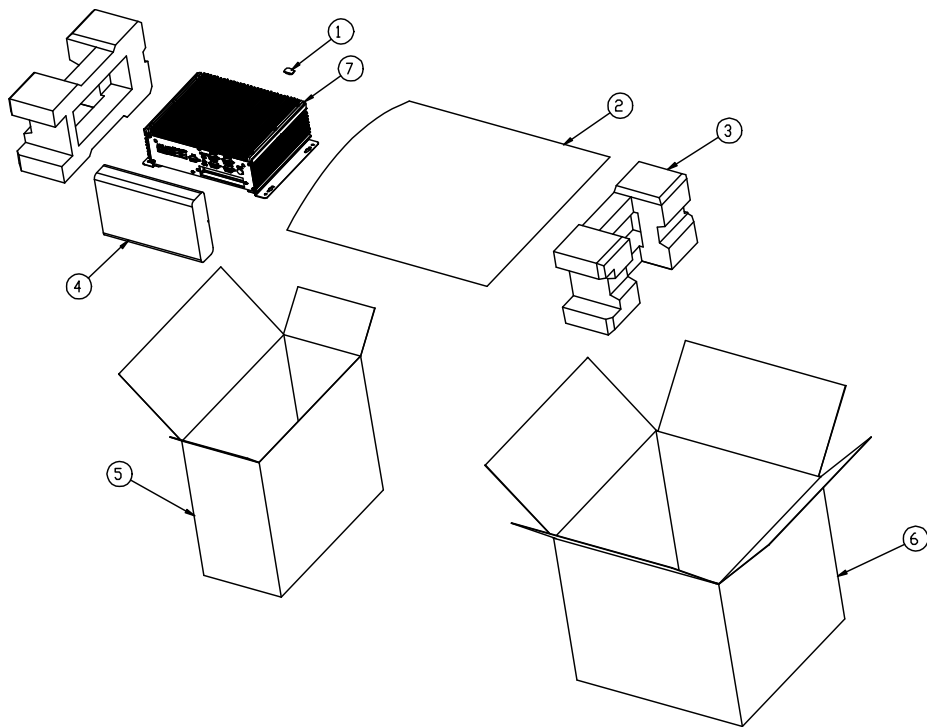

NO	Name	P/N	Q'ty	Remark
Packing assy				
1	SILICA GEL 1gm	34-005-00010007	1	
2	PE Bag 480X460mm	32-100-20010000	1	
3	EPE-5634R	94-016-00301261	2	
4	ACCESS Bag	34-003-01301026	1	
5	Handle Carton	34-003-01301088	1	
6	Outer Carton	34-001-01410006	0.5	
7	SE-8210		1	

EXPLODED DIAGRAM FOR MINI-PCI-E CARD

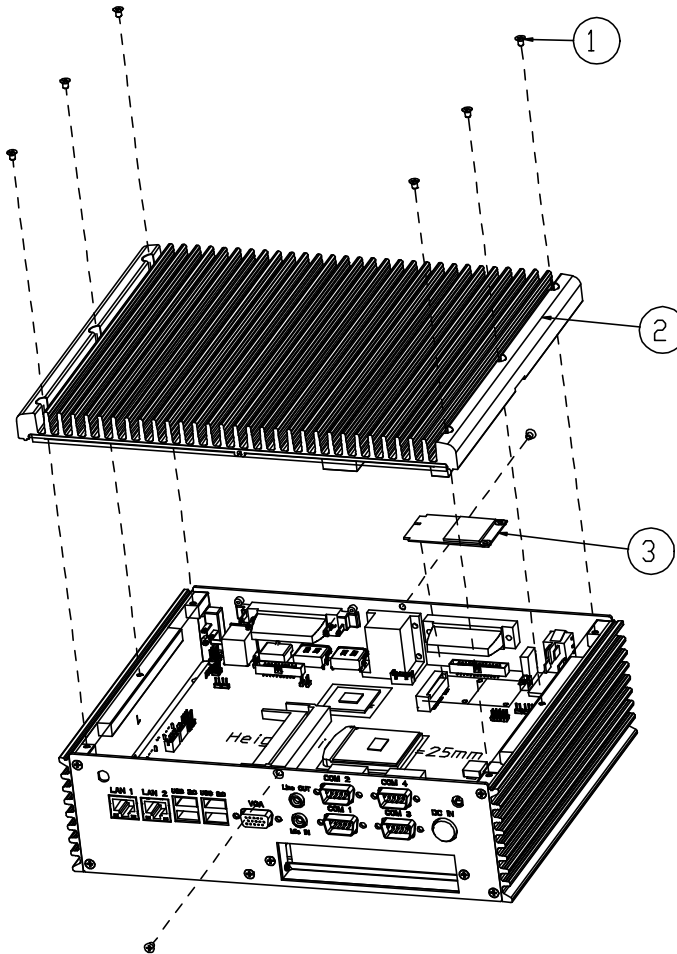

Item	Component	Q'ty
1	M3 Screw	8
2	Heatsink Top Cover	1
3	Mini PCI-e Card	1

EXPLODED DIAGRAM FOR PCI-E CARD

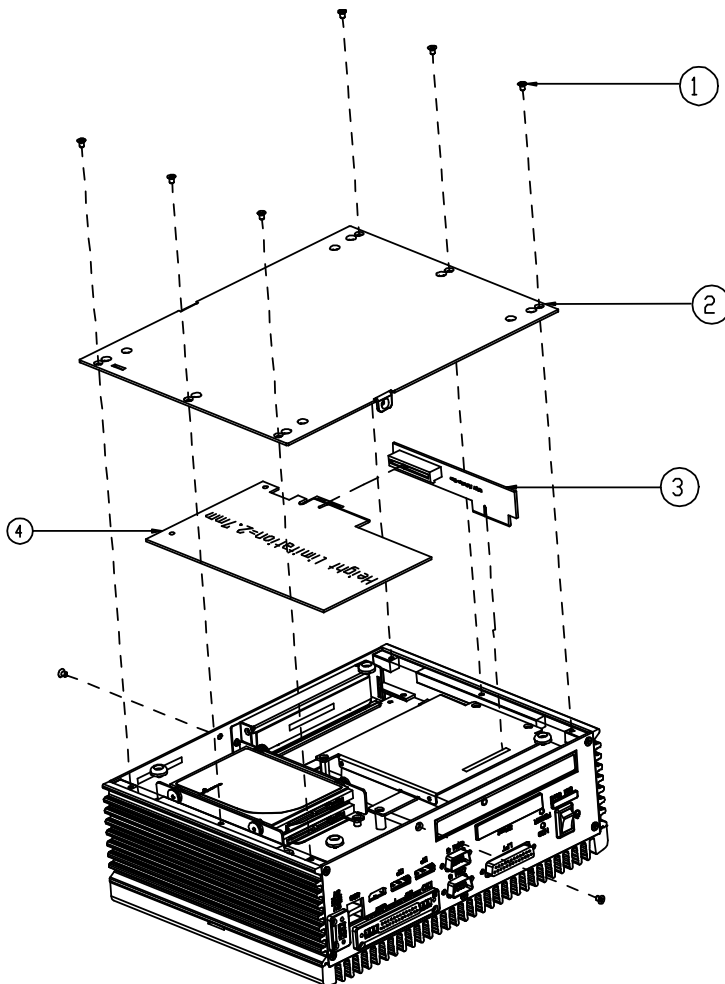

Item	Component	Q'ty	Remark
1	M3 Screw	8	
2	Bottom Bracket	1	
3	PCI-e Riser Card	1	Option
4	PCI-e Card	1	Option

TECHNICAL SUMMARY

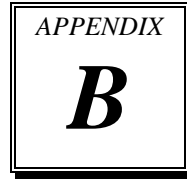

This section introduces you the maps concisely.

Section includes:

- Block Diagram
- Interrupt Map
- DMA Channels Map
- I/O Map
- Watchdog Timer Configuration
- Flash BIOS Update

BLOCK DIAGRAM

SB-8210 Block Diagram

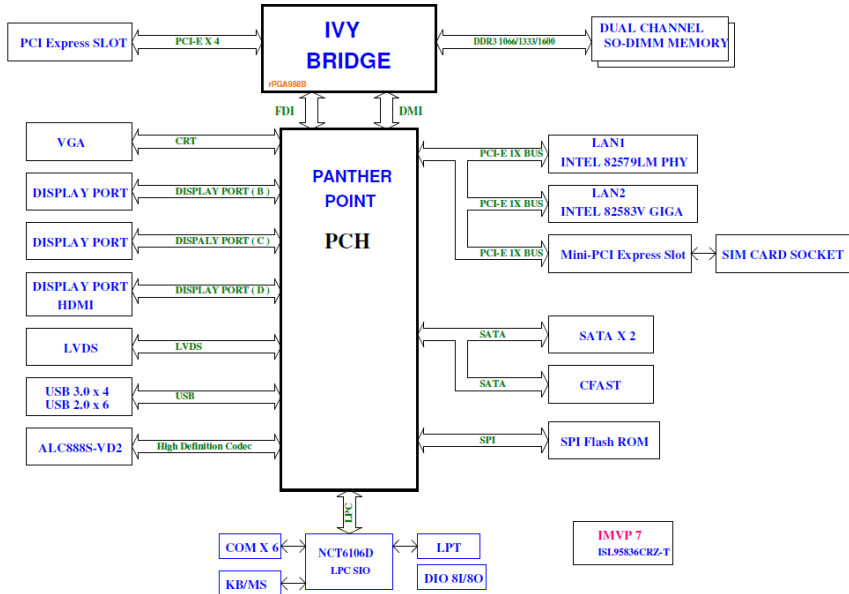

INTERRUPT MAP

IRQ	ASSIGNMENT
IRQ 0	System timer
IRQ 1	Standard PS/2 Keyboard
IRQ 3	Communications Port (COM2)
IRQ 4	Communications Port (COM1)
IRQ 7	Communications Port (COM3)
IRQ 8	System CMOS/real time clock
IRQ 10	Communications Port (COM5)
IRQ 10	Communications Port (COM6)
IRQ 11	Intel(R) 7 Series/C216 Chipset Family SMBus Host Controller - 1E22
IRQ 12	Microsoft PS/2 Mouse
IRQ 13	Numeric data processor
IRQ 16	Intel(R) 7 Series/C216 Chipset Family PCI Express Root Port 1 - 1E10
IRQ 16	Intel(R) 7 Series/C216 Chipset Family USB Enhanced Host Controller - 1E2D
IRQ 16	Intel(R) Management Engine Interface
IRQ 18	Intel(R) 7 Series/C216 Chipset Family PCI Express Root Port 3 - 1E14
IRQ 19	Intel(R) Active Management Technology - SOL (COM7)
IRQ 19	Intel(R) 7 Series/C216 Chipset Family 4 port Serial ATA Storage Controller - 1E01
IRQ 19	Intel(R) 7 Series/C216 Chipset Family 2 port Serial ATA Storage Controller - 1E09
IRQ 22	High Definition Audio Controller
IRQ 23	Intel(R) 7 Series/C216 Chipset Family USB Enhanced Host Controller - 1E26
IRQ 81	Microsoft ACPI-Compliant System

IRQ	ASSIGNMENT
IRQ 82	Microsoft ACPI-Compliant System
IRQ 83	Microsoft ACPI-Compliant System
IRQ 84	Microsoft ACPI-Compliant System
IRQ 85	Microsoft ACPI-Compliant System
IRQ 86	Microsoft ACPI-Compliant System
IRQ 87	Microsoft ACPI-Compliant System
IRQ 88	Microsoft ACPI-Compliant System
IRQ 89	Microsoft ACPI-Compliant System
IRQ 90	Microsoft ACPI-Compliant System
IRQ 91	Microsoft ACPI-Compliant System
IRQ 92	Microsoft ACPI-Compliant System
IRQ 93	Microsoft ACPI-Compliant System
IRQ 94	Microsoft ACPI-Compliant System
IRQ 95	Microsoft ACPI-Compliant System
IRQ 96	Microsoft ACPI-Compliant System
IRQ 97	Microsoft ACPI-Compliant System
IRQ 98	Microsoft ACPI-Compliant System
IRQ 99	Microsoft ACPI-Compliant System
IRQ 100	Microsoft ACPI-Compliant System
IRQ 101	Microsoft ACPI-Compliant System
IRQ 102	Microsoft ACPI-Compliant System
IRQ 103	Microsoft ACPI-Compliant System
IRQ 104	Microsoft ACPI-Compliant System
IRQ 105	Microsoft ACPI-Compliant System
IRQ 106	Microsoft ACPI-Compliant System
IRQ 107	Microsoft ACPI-Compliant System

IRQ	ASSIGNMENT
IRQ 108	Microsoft ACPI-Compliant System
IRQ 109	Microsoft ACPI-Compliant System
IRQ 110	Microsoft ACPI-Compliant System
IRQ 111	Microsoft ACPI-Compliant System
IRQ 112	Microsoft ACPI-Compliant System
IRQ 113	Microsoft ACPI-Compliant System
IRQ 114	Microsoft ACPI-Compliant System
IRQ 115	Microsoft ACPI-Compliant System
IRQ 116	Microsoft ACPI-Compliant System
IRQ 117	Microsoft ACPI-Compliant System
IRQ 118	Microsoft ACPI-Compliant System
IRQ 119	Microsoft ACPI-Compliant System
IRQ 120	Microsoft ACPI-Compliant System
IRQ 121	Microsoft ACPI-Compliant System
IRQ 122	Microsoft ACPI-Compliant System
IRQ 123	Microsoft ACPI-Compliant System
IRQ 124	Microsoft ACPI-Compliant System
IRQ 125	Microsoft ACPI-Compliant System
IRQ 126	Microsoft ACPI-Compliant System
IRQ 127	Microsoft ACPI-Compliant System
IRQ 128	Microsoft ACPI-Compliant System
IRQ 129	Microsoft ACPI-Compliant System
IRQ 130	Microsoft ACPI-Compliant System
IRQ 131	Microsoft ACPI-Compliant System
IRQ 132	Microsoft ACPI-Compliant System
IRQ 133	Microsoft ACPI-Compliant System

IRQ	ASSIGNMENT
IRQ 134	Microsoft ACPI-Compliant System
IRQ 135	Microsoft ACPI-Compliant System
IRQ 136	Microsoft ACPI-Compliant System
IRQ 137	Microsoft ACPI-Compliant System
IRQ 138	Microsoft ACPI-Compliant System
IRQ 139	Microsoft ACPI-Compliant System
IRQ 140	Microsoft ACPI-Compliant System
IRQ 141	Microsoft ACPI-Compliant System
IRQ 142	Microsoft ACPI-Compliant System
IRQ 143	Microsoft ACPI-Compliant System
IRQ 144	Microsoft ACPI-Compliant System
IRQ 145	Microsoft ACPI-Compliant System
IRQ 146	Microsoft ACPI-Compliant System
IRQ 147	Microsoft ACPI-Compliant System
IRQ 148	Microsoft ACPI-Compliant System
IRQ 149	Microsoft ACPI-Compliant System
IRQ 150	Microsoft ACPI-Compliant System
IRQ 151	Microsoft ACPI-Compliant System
IRQ 152	Microsoft ACPI-Compliant System
IRQ 153	Microsoft ACPI-Compliant System
IRQ 154	Microsoft ACPI-Compliant System
IRQ 155	Microsoft ACPI-Compliant System
IRQ 156	Microsoft ACPI-Compliant System
IRQ 157	Microsoft ACPI-Compliant System
IRQ 158	Microsoft ACPI-Compliant System
IRQ 159	Microsoft ACPI-Compliant System

IRQ	ASSIGNMENT
IRQ 160	Microsoft ACPI-Compliant System
IRQ 161	Microsoft ACPI-Compliant System
IRQ 162	Microsoft ACPI-Compliant System
IRQ 163	Microsoft ACPI-Compliant System
IRQ 164	Microsoft ACPI-Compliant System
IRQ 165	Microsoft ACPI-Compliant System
IRQ 166	Microsoft ACPI-Compliant System
IRQ 167	Microsoft ACPI-Compliant System
IRQ 168	Microsoft ACPI-Compliant System
IRQ 169	Microsoft ACPI-Compliant System
IRQ 170	Microsoft ACPI-Compliant System
IRQ 171	Microsoft ACPI-Compliant System
IRQ 172	Microsoft ACPI-Compliant System
IRQ 173	Microsoft ACPI-Compliant System
IRQ 174	Microsoft ACPI-Compliant System
IRQ 175	Microsoft ACPI-Compliant System
IRQ 176	Microsoft ACPI-Compliant System
IRQ 177	Microsoft ACPI-Compliant System
IRQ 178	Microsoft ACPI-Compliant System
IRQ 179	Microsoft ACPI-Compliant System
IRQ 180	Microsoft ACPI-Compliant System
IRQ 181	Microsoft ACPI-Compliant System
IRQ 182	Microsoft ACPI-Compliant System
IRQ 183	Microsoft ACPI-Compliant System
IRQ 184	Microsoft ACPI-Compliant System
IRQ 185	Microsoft ACPI-Compliant System

IRQ	ASSIGNMENT
IRQ 186	Microsoft ACPI-Compliant System
IRQ 187	Microsoft ACPI-Compliant System
IRQ 188	Microsoft ACPI-Compliant System
IRQ 189	Microsoft ACPI-Compliant System
IRQ 190	Microsoft ACPI-Compliant System
IRQ 4294967292	Intel(R) 82579LM Gigabit Network Connection
IRQ 4294967293	Intel(R) USB 3.0 eXtensible Host Controller
IRQ 4294967294	Intel(R) HD Graphics 4000

Note: These resource information were gathered using Windows 7 (the IRQ could be assigned differently depending on OS)

DMA CHANNELS MAP

TIMER CHANNEL	ASSIGNMENT
Channel 4	Direct memory access controller

I/O MAP

I/O MAP	ASSIGNMENT
0x00000000-0x0000001F	Direct memory access controller
0x00000000-0x0000001F	PCI bus
0x00000010-0x0000001F	Motherboard resources
0x00000020-0x00000021	Programmable interrupt controller
0x00000022-0x0000003F	Motherboard resources
0x00000024-0x00000025	Programmable interrupt controller
0x00000028-0x00000029	Programmable interrupt controller
0x0000002C-0x0000002D	Programmable interrupt controller
0x0000002E-0x0000002F	Motherboard resources
0x00000030-0x00000031	Programmable interrupt controller
0x00000034-0x00000035	Programmable interrupt controller
0x00000038-0x00000039	Programmable interrupt controller
0x0000003C-0x0000003D	Programmable interrupt controller
0x00000040-0x00000043	System timer
0x00000044-0x0000005F	Motherboard resources
0x0000004E-0x0000004F	Motherboard resources
0x00000050-0x00000053	System timer
0x00000060-0x00000060	Standard PS/2 Keyboard
0x00000061-0x00000061	Motherboard resources
0x00000063-0x00000063	Motherboard resources
0x00000064-0x00000064	Standard PS/2 Keyboard
0x00000065-0x00000065	Motherboard resources
0x00000067-0x00000067	Motherboard resources
0x00000070-0x00000077	System CMOS/real time clock
0x00000070-0x00000077	Motherboard resources

I/O MAP	ASSIGNMENT
0x00000072-0x0000007F	Motherboard resources
0x00000080-0x00000080	Motherboard resources
0x00000080-0x00000080	Motherboard resources
0x00000081-0x00000091	Direct memory access controller
0x00000084-0x00000086	Motherboard resources
0x00000088-0x00000088	Motherboard resources
0x0000008C-0x0000008E	Motherboard resources
0x00000090-0x0000009F	Motherboard resources
0x00000092-0x00000092	Motherboard resources
0x00000093-0x0000009F	Direct memory access controller
0x000000A0-0x000000A1	Programmable interrupt controller
0x000000A2-0x000000BF	Motherboard resources
0x000000A4-0x000000A5	Programmable interrupt controller
0x000000A8-0x000000A9	Programmable interrupt controller
0x000000AC-0x000000AD	Programmable interrupt controller
0x000000B0-0x000000B1	Programmable interrupt controller
0x000000B2-0x000000B3	Motherboard resources
0x000000B4-0x000000B5	Programmable interrupt controller
0x000000B8-0x000000B9	Programmable interrupt controller
0x000000BC-0x000000BD	Programmable interrupt controller
0x000000C0-0x000000DF	Direct memory access controller
0x000000E0-0x000000EF	Motherboard resources
0x000000F0-0x000000FF	Numeric data processor
0x00000290-0x0000029F	Motherboard resources
0x000002A0-0x000002AF	Motherboard resources
0x000002E0-0x000002E7	Communications Port (COM5)

I/O MAP	ASSIGNMENT
0x000002E8-0x000002EF	Communications Port (COM4)
0x000002F0-0x000002F7	Communications Port (COM6)
0x000002F8-0x000002FF	Communications Port (COM2)
0x00000378-0x0000037F	Printer Port (LPT1)
0x000003B0-0x000003BB	Intel(R) HD Graphics 4000
0x000003C0-0x000003DF	Intel(R) HD Graphics 4000
0x000003E8-0x000003EF	Communications Port (COM3)
0x000003F8-0x000003FF	Communications Port (COM1)
0x00000400-0x00000453	Motherboard resources
0x00000454-0x00000457	Motherboard resources
0x00000458-0x0000047F	Motherboard resources
0x000004D0-0x000004D1	Motherboard resources
0x000004D0-0x000004D1	Programmable interrupt controller
0x00000500-0x0000057F	Motherboard resources
0x00000680-0x0000069F	Motherboard resources
0x00000D00-0x0000FFFF	PCI bus
0x00001000-0x0000100F	Motherboard resources
0x0000164E-0x0000164F	Motherboard resources
0x0000E000-0x0000EFFF	Intel(R) 7 Series/C216 Chipset Family PCI Express Root Port 3 - 1E14
0x0000F000-0x0000F03F	Intel(R) HD Graphics 4000
0x0000F040-0x0000F05F	Intel(R) 7 Series/C216 Chipset Family SMBus Host Controller - 1E22
0x0000F080-0x0000F08F	Intel(R) 7 Series/C216 Chipset Family 2 port Serial ATA Storage Controller - 1E09
0x0000F090-0x0000F09F	Intel(R) 7 Series/C216 Chipset Family 2 port Serial ATA Storage Controller - 1E09
0x0000F0A0-0x0000F0A3	Intel(R) 7 Series/C216 Chipset Family 2 port Serial ATA Storage Controller - 1E09

I/O MAP	ASSIGNMENT
0x0000F0B0-0x0000F0B7	Intel(R) 7 Series/C216 Chipset Family 2 port Serial ATA Storage Controller - 1E09
0x0000F0C0-0x0000F0C3	Intel(R) 7 Series/C216 Chipset Family 2 port Serial ATA Storage Controller - 1E09
0x0000F0D0-0x0000F0D7	Intel(R) 7 Series/C216 Chipset Family 2 port Serial ATA Storage Controller - 1E09
0x0000F0E0-0x0000F0EF	Intel(R) 7 Series/C216 Chipset Family 4 port Serial ATA Storage Controller - 1E01
0x0000F0F0-0x0000F0FF	Intel(R) 7 Series/C216 Chipset Family 4 port Serial ATA Storage Controller - 1E01
0x0000F100-0x0000F103	Intel(R) 7 Series/C216 Chipset Family 4 port Serial ATA Storage Controller - 1E01
0x0000F110-0x0000F117	Intel(R) 7 Series/C216 Chipset Family 4 port Serial ATA Storage Controller - 1E01
0x0000F120-0x0000F123	Intel(R) 7 Series/C216 Chipset Family 4 port Serial ATA Storage Controller - 1E01
0x0000F130-0x0000F137	Intel(R) 7 Series/C216 Chipset Family 4 port Serial ATA Storage Controller - 1E01
0x0000F140-0x0000F147	Intel(R) Active Management Technology - SOL (COM7)
0x0000FFFF-0x0000FFFF	Motherboard resources
0x0000FFFF-0x0000FFFF	Motherboard resources

WATCHDOG TIMER CONFIGURATION

The I/O port address of the watchdog timer is 2E (hex) and 2F (hex). 2E (hex) is the address port. 2F (hex) is the data port. User must first assign the address of register by writing address value into address port 2E (hex), then write/read data to/from the assigned register through data port 2F (hex).

Configuration Sequence

To program **NCT6106** configuration registers, the following configuration sequence must be followed:

- (1) Enter the extended function mode
- (2) Configure the configuration registers
- (3) Exit the extended function mode

(1) Enter the extended function mode

To place the chip into the Extended Function Mode, two successive writes of 0x87 must be applied to Extended Function Enable Registers (EFERs, i.e. 2Eh or 4Eh).

(2) Configure the configuration registers

The chip selects the Logical Device and activates the desired Logical Devices through Extended Function Index Register (EFIR) and Extended Function Data Register (EFDR). The EFIR is located at the same address as the EFER, and the EFDR is located at address (EFIR+1). First, write the Logical Device Number (i.e. 0x07) to the EFIR and then write the number of the desired Logical Device to the EFDR. If accessing the Chip (Global) Control Registers, this step is not required. Secondly, write the address of the desired configuration register within the Logical Device to the EFIR and then write (or read) the desired configuration register through the EFDR.

(3) Exit the extended function mode

To exit the Extended Function Mode, writing 0xAA to the EFER is required. Once the chip exits the Extended Function Mode, it is in the normal running mode and is ready to enter the configuration mode.

Example Program

Enable watchdog timer and set 30 sec. as timeout interval

```
;----- Enter to extended function mode -----  
Mov   dx,    2eh  
Mov   al,    87h  
Out   dx,    al  
Out   dx,    al  
;----- Select Logical Device 8 of watchdog timer -----  
Mov   al,    07h  
Out   dx,    al  
Inc   dx  
Mov   al,    08h  
Out   dx,    al  
;----- Set second as counting unit -----  
Dec   dx  
Mov   al,    0f5h  
Out   dx,    al  
Inc   dx  
In    al,    dx  
And   al,    not 08h  
Out   dx,    al  
;----- Set timeout interval as 30seconds and start counting -----  
Dec   dx  
Mov   al,    0f6h  
Out   dx,    al  
Inc   dx  
Mov   al,    30  
Out   dx,    al  
;----- Exit the extended function mode -----  
Dec   dx  
Mov   al,    0aah  
Out   dx,    al
```

FLASH BIOS UPDATE

I. Before System BIOS update

1. Prepare a bootable media (ex. USB storage device) which can boot system to DOS prompt.
2. Download and save the BIOS file (ex. [82100TQ6.bin](#)) to the bootable device.
3. Copy AMI flash utility – AFUDOS.exe (v2.35) into bootable device.

```
C:\8210>dir
Volume in driver C is PROTECH
Volume Serial Number is 3CCE-a150
Directory of C : \8210

.                <DIR>                12-14-12  5: 50P
..               <DIR>                12-14-12  5: 50p
AFUDOS  EXE           159,008    03-04-10  4: 16p
README  TXT             2,684     03-04-10  2:33p
AFUDOS  TXT             2,906     03-04-10  3:02p
82100TQ6 BIN          8,388,608  12-24-12  3:32p
         4 file(s)              8,553,206 bytes
         2 dir(s)              787,197,952 bytes free

C:\8210>
```

4. Make sure the target system can first boot to the bootable device.
 - a. Connect the bootable USB device.
 - b. Turn on the computer and press <F2> or key during boot to enter BIOS Setup.
 - c. System will go into the BIOS setup menu.
 - d. Select [Boot] menu.
 - e. Select [Hard Drive BBS Priorities], set the USB bootable device to be the 1st boot device.
 - f. Press <F4> key to save configuration and exit the BIOS setup menu.

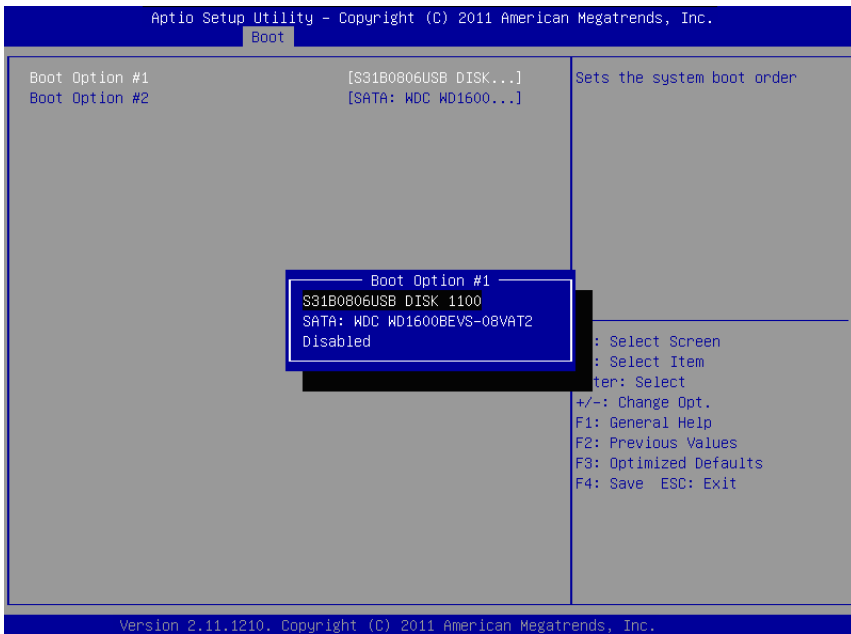

II. AFUDOS command for system BIOS update

AFUDOS.exe is the AMI firmware update utility; the command line is shown as below:

AFUDOS <ROM File Name> [option1] [option2]....

You can type “**AFUDOS/ ?**” to see all the definition of each control options. The recommended options for BIOS ROM update include following parameters:

- /P:** Program main BIOS image.
- /B:** Program Boot Block.
- /N:** Program NVRAM.
- /X:** Don't check ROM ID.

III. BIOS update procedure

1. Use the bootable USB storage to boot up system into the DOS command prompt.
2. Type "**AFUDOS 8210xxxx.bin /p /b /n /x**" and press enter to start the flash procedure.
(Note that **xxxx** means the BIOS revision part, ex. 0PQ1...)
3. During the update procedure, you will see the BIOS update process status and its percentage. Beware! Do not turn off system power or reset your computer if the whole procedure are not complete yet, or it may crash the BIOS ROM and make system unable to boot up next time.
4. After BIOS update procedures is complete, the messages should be like the figure shown below.

```
C:\DOS>afudos 82100TQ6.BIN /P /B /N /X
+-----+
|               AMI Firmware Update Utility(APTIO) v2.35               |
|      Copyright (c) 2010 American Megatrends Inc. All Rights Reserved.      |
+-----+
Reading file .....done
FFS checksums .....ok
Erasing flash .....done
Writing flash .....done
Verifying flash .....done
Erasing NVRAM .....done
Writing NVRAM .....done
Verifying NVRAM .....done
Erasing BootBlock .....done
Verifying BootBlock .....done

C:\>DOS>
```

5. User can restart the system and boot up with new BIOS now.
6. Update is complete after restart.
7. Verify during following boot that the BIOS version displayed at initialization screen has changed.



**American
Megatrends**

Version: 2.15.1234. Copyright (C) 2012 American Magatrends, Inc.

BIOS Date: 12 / 18 / 2012 12:00:00 Ver : 82100TQ6

Press or <F2> to enter Setup.