

# **USER'S MANUAL**

**SE-8124**

**Slim and Fanless  
Intel® E3845 / J1900  
Processor Embedded PC**

**SE-8124 M4**

***SE-8124***  
***Slim and Fanless Intel® E3845/J1900***  
***Processor Embedded PC with***  
***4COM/2DVI/2LAN/4USB***

**COPYRIGHT NOTICE**

All trademarks and registered trademarks mentioned herein are the property of their respective owners.

This manual is copyrighted in May 2022. You may not reproduce or transmit in any form or by any means, electronic, or mechanical, including photocopying and recording.

**DISCLAIMER**

This user's manual is meant to assist you in installing and setting up the system. The information contained in this document is subject to change without any notice.

**CE NOTICE**

This is a class A product. In a domestic environment this product may cause radio interference in which case the user may be required to take adequate measures.

## **FCC NOTICE**

This equipment has been tested and found to comply with the limits for a Class A digital device, pursuant to part 15 of the FCC Rules. These limits are designed to provide reasonable protection against harmful interference when the equipment is operated in a commercial environment. This equipment generates, uses, and can radiate radio frequency energy and, if not installed and used in accordance with the instruction manual, may cause harmful interference to radio communications. Operation of this equipment in a residential area is likely to cause harmful interference in which case the user will be required to correct the interference at his own expense.

You are cautioned that any change or modifications to the equipment not expressly approve by the party responsible for compliance could void your authority to operate such equipment.

**WARNING!** Some internal parts of the system may have high electrical voltage. And therefore we strongly recommend that qualified engineers can open and disassemble the system.  
**RESTRICTED ACCESS LOCATION:** access can only be gained by **SERVICE PERSONS** or by **USERS** who have been instructed about the reasons for the restrictions applied to the location and about any precautions that shall be taken; and access is through the use of a **TOOL** or lock and key, or other means of security, and is controlled by the authority responsible for the location

## TABLE OF CONTENTS

### CHAPTER 1 INTRODUCTION

1-1	About This Manual.....	1-2
1-2	System Illustration.....	1-3
1-3	System Specifications.....	1-5
1-4	Safety Precautions.....	1-7

### CHAPTER 2 SYSTEM CONFIGURATION

2-1	Jumper & Connector Quick Reference Table.....	2-2
2-2	Component Locations.....	2-3
2-3	How to Set the Jumpers.....	2-5
2-4	PWR In Connector.....	2-7
2-5	COM Port & Connector.....	2-7
2-6	COM Port RI & Voltage Selection.....	2-10
2-7	USB Port.....	2-10
2-8	LAN Port.....	2-12
2-9	DVI Connector.....	2-14
2-10	Digital I/O Connector.....	2-16
2-11	Audio Connector.....	2-17
2-12	SATA & SATA Power Connector.....	2-18
2-13	LVDS Connector.....	2-19
2-14	Inverter Connector.....	2-20
2-15	Backlight Level Selection Connector.....	2-21
2-16	Clear CMOS Data Selection.....	2-22
2-17	Panel Resolution Selection.....	2-23
2-18	LVDS VCC Selection.....	2-24
2-19	DVI-D Enable Selection.....	2-25
2-20	DVI-D HPD Enable Selection.....	2-26
2-21	Power Mode Selection.....	2-26
2-22	DDC Selection.....	2-27

### CHAPTER 3 SOFTWARE UTILITIES

3-1	Introduction.....	3-2
3-2	Intel® Chipset Software Installation Utility.....	3-3
3-3	Intel® Trusted Execution Engine Driver installation.....	3-4
3-4	Intel® Kernel-Mode Driver Framework Driver Installation....	3-5
3-5	Intel® Mailbox Interface Device Driver.....	3-6
3-6	For USB3.0 Driver installation.....	3-7

3-7	VGA Driver Utility.....	3-8
3-8	LAN Driver Utility.....	3-9
3-9	Sound Driver Utility.....	3-10
3-10	Card Reader Driver Utility.....	3-11

## **CHAPTER 4 SYSTEM INSTALLATION**

4-1	Removing the bottom case.....	4-2
4-2	HDD Installation.....	4-4
4-3	SO-DIMM Installation.....	4-8
4-4	Wireless LAN or 3G module Installation.....	4-12
4-5	PoE Board Installation.....	4-17

## **CHAPTER 5 AMI BIOS SETUP**

5-1	Introduction.....	5-2
5-2	Accessing Setup.....	5-4
5-3	Main.....	5-7
5-4	Advanced.....	5-8
5-5	Chipset.....	5-32
5-6	Security.....	5-40
5-7	Boot.....	5-41
5-8	Save & Exit.....	5-44

## **APPENDIX A SYSTEM ASSEMBLY**

	Exploded Diagram for Bottom Case.....	A-2
	Exploded Diagram for HDD Support Board.....	A-3
	Exploded Diagram for Front & Rear Case.....	A-4
	Exploded Diagram for Motherboard.....	A-5
	Exploded Diagram for Heatsink.....	A-6

## **APPENDIX B TECHNICAL SUMMARY**

	Block Diagram.....	B-2
	Interrupt Map.....	B-3
	I/O Map.....	B-8
	Memory Map.....	B-11
	Watchdog Timer Configuration.....	B-13
	Flash BIOS Update.....	B-15



# ***INTRODUCTION***

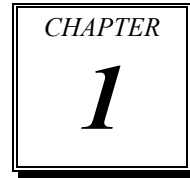

This chapter gives you the information for SE-8124. It also outlines the System specification.

Section includes:

- About This Manual
- System Specifications
- Safety Precautions

**Experienced users can skip to chapter 2 on page 2-1 for Quick Start.**

## **1-1. ABOUT THIS MANUAL**

Thank you for purchasing our SE-8124 Intel® E3845/J1900 Embedded PC. SE-8124 provides faster processing speed, greater expandability and can handle more task than before. This manual is designed to assist you how to install and set up the system. It contains four chapters. Users can apply this manual for configuration according to the following chapters:

### ***Chapter 1 Introduction***

This chapter introduces you to the background of this manual, and the specifications for this system. The final page of this chapter will indicate how to avoid damaging this board.

### ***Chapter 2 Hardware Configuration***

This chapter outlines the component locations and their functions. In the end of this chapter, you will learn how to set jumper and how to configure this card to meet your own needs.

### ***Chapter 3 Software Utilities***

This chapter contains helpful information for proper installations of the VGA utility, LAN utility, Sound utility and Card Reader utility.

### ***Chapter 4 AMI BIOS Setup***

This chapter indicates you how to set up the BIOS configurations.

### ***Appendix A System Assembly***

This appendix gives you the exploded diagrams and part numbers of the SE-8124.

### ***Appendix B Technical Summary***

This appendix gives you the information about the Block diagram, Technical maps, Watchdog-timer configuration, and Flash BIOS Update.



## 1-2. SYSTEM ILLUSTRATION

Front View

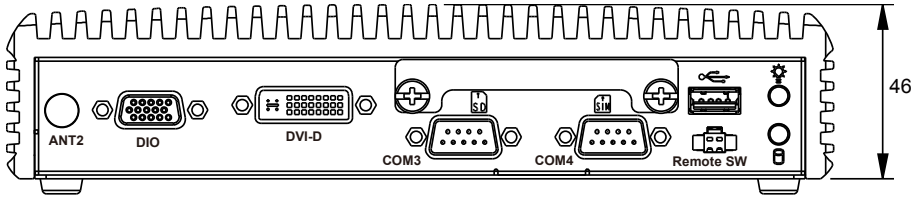

Rear View

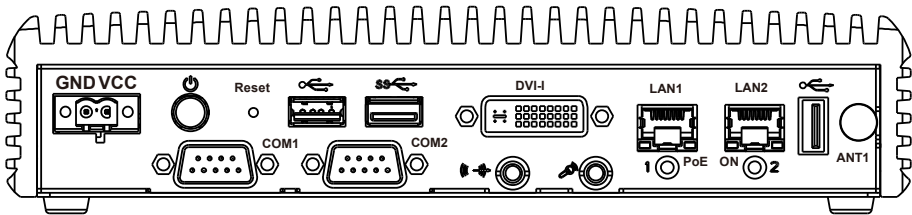

Top View

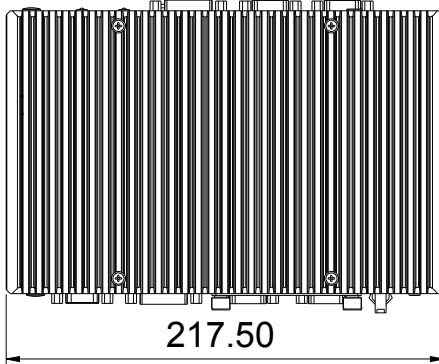

Quarter View

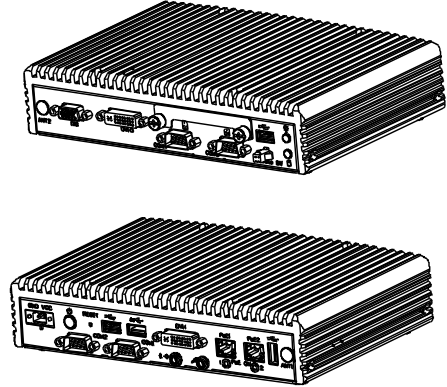

Side View

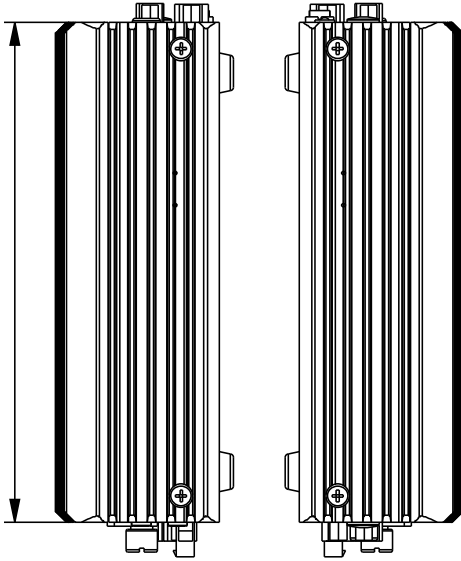

140.60

## 1-3. SYSTEM SPECIFICATION

### System

CPU Support	Intel® J1900/E3845 CPU
Chipset	Intel® SOC
OS Support	Win7/ Win8.1/ WES7/ WE 8.1 Industry Pro
Memory Support	1 x DDR3L SO-DIMM Socket (up to 8 GB)
Drive Bay	1 x 2.5 inch SATA HDD or SSD driver space
Power Requirement	12~24V DC-IN
Watchdog	1~255s Watchdog timer
Expansion Slot	1x full size miniPCle (PCle+USB+external SIM card) 1x half size miniPCle (PCle+USB)
System Weight	2.5 kg
Dimension (W x H x D)	217.5 x 46 x 148 mm (8.56" x 1.77" x 5.83" )
Certificate	FCC/CE

### I/O Ports

Serial Port	COM3/4 for RS232 (front), COM1/2 for +5V/+12V/RI selectable by jumper,RS232/422/485 selectable by BIOS
Digital I/O	4-in/4-out (front)
USB	1 x USB 2.0 port (front), 2 x USB 2.0, 1 x USB 3.0 (rear)
DVI	DVI 1 x DVI-D (front), 1 x DVI-I (rear)
SIM	1 x SIM card slot with cover
SD	1 x SD Card with cover
Audio	Realtek high definition audio, 1x Line-Out & 1x MIC In audio jack by pin header
LAN	2 x RJ45 connector with PoE support Wake on LAN/ PXE
Power ON/OFF	1x power button switch (rear), 1x 2pin connector for remote power button (front)
Reset	1x reset (rear)

**Environment**

Operating Temp. (with air)	0~45°C (32~113°F),with ST SSD 0~40°C (32~104°F), with HDD -30~60°C (-22~140°F) with wide temp. peripherals w/o PoE (w/o Audio) (E3845 only) -30~55 °C (-22~131°F) with wide temp. peripherals with PoE (w/o Audio) (E3845 only)
Storage Temp.	-30 ~ 80°C (-22~ 176°F)
Humidity	Operating: 10 ~ 90%, Storage: 10~95%RH

## **1-4. SAFETY PRECAUTIONS**

Follow the messages below to avoid your systems from damage:

1. Keep your system away from static electricity on all occasions.
2. Prevent electric shock. Don't touch any components of this card when the card is power-on. Always disconnect power when the system is not in use.
3. Disconnect power when you change any hardware devices. For instance, when you connect a jumper or install any cards, a surge of power may damage the electronic components or the whole system.

# ***HARDWARE CONFIGURATION***

CHAPTER

**2**

## ***\*\* QUICK START \*\****

Helpful information describes the jumper & connector settings, and component locations.

Section includes:

- Jumper & Connector Quick Reference Table
- Component Locations
- Configuration and Jumper settings
- Connector's Pin Assignments

## **2-1. JUMPER & CONNECTOR QUICK REFERENCE TABLE**

<b>JUMPER / CONNECTOR</b>	<b>NAME</b>
Pwr In Connector	CN_POWER1
COM Port & Connector	COM1, COM2, COM3, COM4, COM5, COM6
COM Port Ri & Voltage Selection	JPCOM1, JPCOM2
USB Port	USB4, USB2, USB3, USB5
LAN Port	LAN1, LAN2
DVI Connector	DVI1, DVI2
Digital I/O Connector	DIO1, JDIO1
Audio Connector	JAUDIO1
SATA & SATA Power Connector	SATA1, HDD_POWER1
LVDS Connector	LVDS1
Inverter Connector	INV1
Backlight Level Selection Connector	JP_BLEN1
Clear CMOS Data Selection	JP2
Panel Resolution Selection	JP4, JP5
LVDS VCC Selection	JP6
DVI-D Enable Selection	JP34, JP35
DVI-D HPD Enable Selection	JP37
Power Mode Selection	JP39
DDV Selection	JP13

## 2-2. COMPONENT LOCATIONS

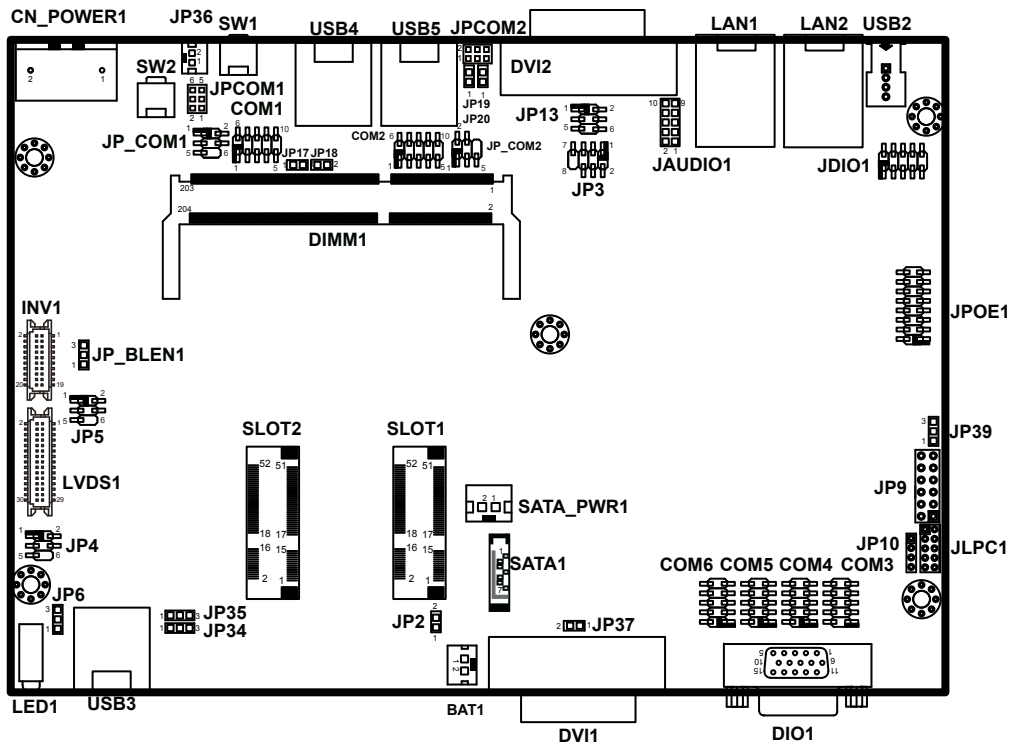

SE-8124 Connectors, Jumpers and Components Locations - Front



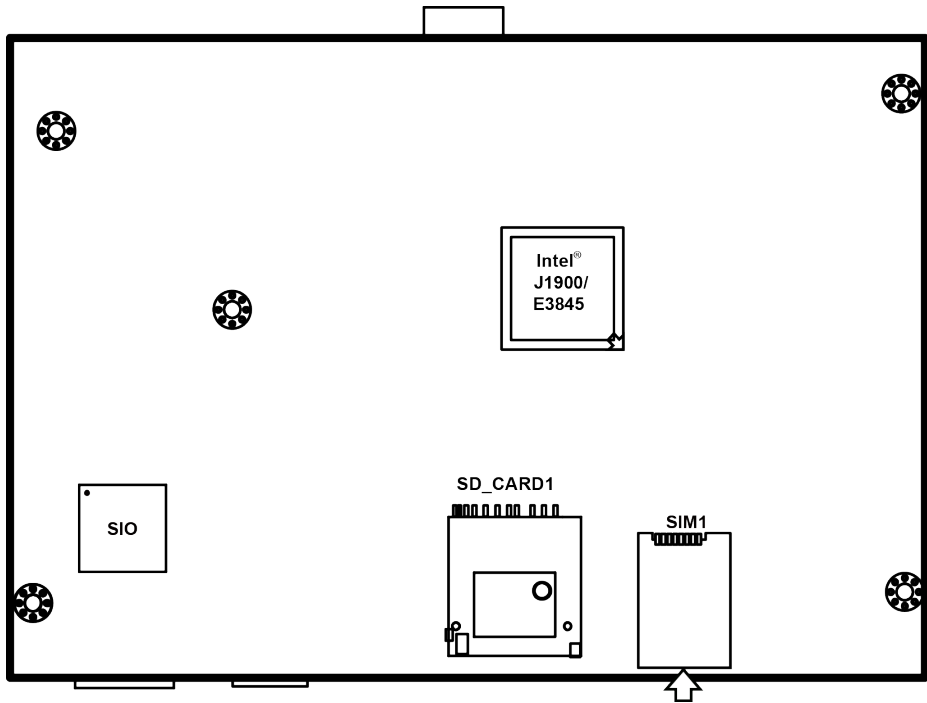

SE-8124 Connectors, Jumpers and Components Locations - Rear

## 2-3. HOW TO SET THE JUMPERS

You can configure your board by setting jumpers. Jumper is consists of two or three metal pins with a plastic base mounted on the card, and by using a small plastic "cap", Also known as the jumper cap (with a metal contact inside), you are able to connect the pins. So you can set-up your hardware configuration by "open" or "close" pins.

The jumper can be combined into sets that called jumper blocks. When the jumpers are all in the block, you have to put them together to set up the hardware configuration. The figure below shows how this looks like.

### JUMPERS AND CAPS

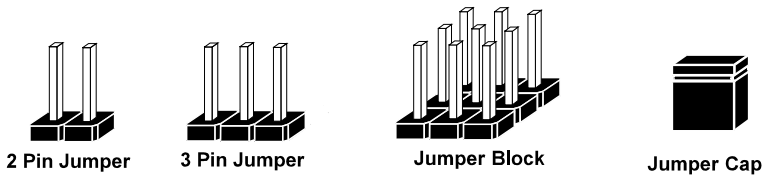

If a jumper has three pins (for examples, labelled PIN1, PIN2, and PIN3), You can connect PIN1 & PIN2 to create one setting by shorting. You can either connect PIN2 & PIN3 to create another setting. The same jumper diagrams are applied all through this manual. The figure below shows what the manual diagrams look and what they represent.

### JUMPER DIAGRAMS



Jumper Cap  
looks like this



2 pin Jumper  
looks like this

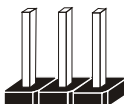

3 pin Jumper  
looks like this

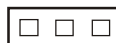

Jumper Block  
looks like this

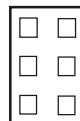

### JUMPER SETTINGS



2 pin Jumper close(enabled)  
Looks like this



1

1



3 pin Jumper  
2-3 pin close(enabled)  
Looks like this



1

1



Jumper Block  
1-2 pin close(enabled)  
Looks like this

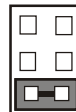

1 2

1 2

## 2-4. PWR IN CONNECTOR

**CN\_POWER1:** PWR IN Connector

The pin assignments are as follows:

PIN	ASSIGNMENT
1	PWRI(12~24V)
2	GND

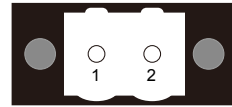

**CN\_POWER1**

## 2-5.COM PORT & CONNECTOR

**COM1/COM2 :** RS-232/422/485, default RS-232

The pin assignments are as follows:

PIN	ASSIGNMENT		
	RS-232	RS-422	RS-485
1	DCD#	TX-	RS-485-
2	RX	TX+	RS-485+
3	TX	RX+	X
4	DTR#	RX-	X
5	GND	GND	GND
6	DSR#	X	X
7	RTS#	X	X
8	CTS#	X	X
9	RI#	X	X
10	NC	NC	NC

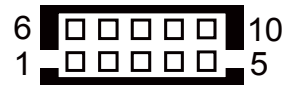

**COM1/COM2/COM3/  
COM4/COM5/COM6**

**COM3,COM4,COM5,COM6: COM Connectors**

The pin assignments are as follows:

**COM3:**

<b>PIN</b>	<b>ASSIGNMENT</b>	<b>PIN</b>	<b>ASSIGNMENT</b>
1	COM3_DCD_C	6	COM3_DSR_C
2	COM3_RX_C	7	COM3_RTS_C
3	COM3_TX_C	8	COM3_CTS_C
4	COM3_DTR_C	9	COM3_RI_C
5	GND	10	NC

**COM4:**

<b>PIN</b>	<b>ASSIGNMENT</b>	<b>PIN</b>	<b>ASSIGNMENT</b>
1	COM4_DCD_C	6	COM4_DSR_C
2	COM4_RX_C	7	COM4_RTS_C
3	COM4_TX_C	8	COM4_CTS_C
4	COM4_DTR_C	9	COM4_RI_C
5	GND	10	NC

**COM5:**

<b>PIN</b>	<b>ASSIGNMENT</b>	<b>PIN</b>	<b>ASSIGNMENT</b>
1	COM5_DCD_C	6	COM5_DSR_C
2	COM5_RX_C	7	COM5_RTS_C
3	COM5_TX_C	8	COM5_CTS_C
4	COM5_DTR_C	9	COM5_RI_C
5	GND	10	NC

**COM6:**



PIN	ASSIGNMENT	PIN	ASSIGNMENT
1	COM6_DCD_C	6	COM6_DSR_C
2	COM6_RX_C	7	COM6_RTS_C
3	COM6_TX_C	8	COM6_CTS_C
4	COM6_DTR_C	9	COM6_RI_C
5	GND	10	NC

**Note:** COM1/2 connectors are selectable for RI, +5V or +12V. For more information, please refer to *COM PORT & VOLTAGE SELECTION*.

## 2-6. COM PORT RI & VOLTAGE SELECTION

### JPCOM1, JPCOM2: COM Port RI & Voltage Selection

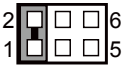
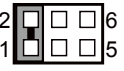
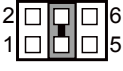
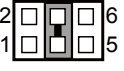
The jumper settings are as follows:

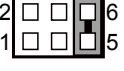
SELECTION	JUMPER SETTING	JUMPER ILLUSTRATION	
RI (default)	1-2	 <b>JPCOM1</b>	 <b>JPCOM2</b>
VCC12	3-4	 <b>JPCOM1</b>	 <b>JPCOM2</b>
VCC5V	5-6	 <b>JPCOM1</b>	 <b>JPCOM2</b>

Note: The manufacturing default is RI

## 2-7.USB Connector

### USB2: Internal USB Connector

The pin assignment is as follows:

PIN	ASSIGNMENT
1	VCC5V
2	USBC2N
3	USBC2P
4	GND
5	GND

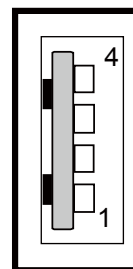

**USB2**

**USB3:** Internal USB Connector

The pin assignment is as follows:

PIN	ASSIGNMENT
1	VCC5V
2	USBC3N
3	USBC3P
4	GND
5	GND

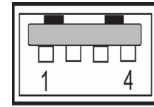

**USB3**

**USB4:** Internal USB Connector

The pin assignment is as follows:

PIN	ASSIGNMENT
1	VCC5V
2	USBC4N
3	USBC4P
4	GND
5	GND

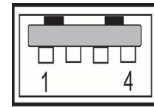

**USB4**

**USB5:** Internal USB3.0 Connector

The pin assignment is as follows:

PIN	ASSIGNMENT
1	VCC5V
2	USBB_DM
3	USBB_DP
4	GND
5	U3RXNDN1
6	U3RXNDP1
7	GND
8	U3TXDN1
9	U3TXDP1

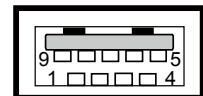

**USB5**



## 2-8. LAN PORT

### LAN1: LAN Connectors

The pin assignments are as follows:

PIN	ASSIGNMENT
1	MDI_0P
2	MDI_0N
3	MDI_1P
4	MDI_2P
5	MDI_2N
6	MDI_1N
7	MDI_3P
8	MDI_3N

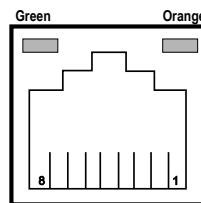

**LAN1**

### LAN LED Indicator:

#### Left Side LED

Green Color Blinking	LAN Message Active
Off	No LAN Message Active

#### Right Side LED

Orange Color On	10/100 LAN Speed Indicator
Red Color On	Giga LAN Speed Indicator
Off	No LAN switch/ hub connected.

**LAN2: LAN Connectors**

The pin assignments are as follows:

PIN	ASSIGNMENT
1	MDI_0P
2	MDI_0N
3	MDI_1P
4	MDI_2P
5	MDI_2N
6	MDI_1N
7	MDI_3P
8	MDI_3N

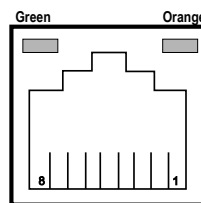

**LAN2**

**LAN LED Indicator:**

**Left Side LED**

Green Color Blinking	LAN Message Active
Off	No LAN Message Active

**Right Side LED**

Orange Color On	10/100 LAN Speed Indicator
Red Color on	Giga LAN Speed Indicator
Off	No LAN switch/ hub connected.

## 2-9. DVI CONNECTOR

### DVI2: DVI-I Connector

The pin assignment is as follows:

PIN	ASSIGNMENT
1	DVI 2-
2	DVI 2+
3	GND
4	NC
5	NC
6	DVI clock
7	DVI data
8	CRT VSYNC
9	DVI 1-
10	DVI 1+
11	GND
12	NC
13	NC
14	VCC
15	GND
16	DVI HPD
17	DVI 0-
18	DVI 0+
19	GND
20	NC
21	NC
22	GND
23	DVI_Clock+
24	DVI_Clock-
C1	CRT RED
C2	CRT GREEN
C3	CRT BLUE
C4	CRT HSYNC
C5	GND

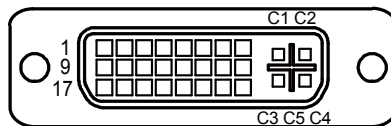

**DVI2**

**DVI1:** DVI-D Connector

The pin assignment is as follows:

PIN	ASSIGNMENT
1	DVI 2-
2	DVI 2+
3	GND
4	NC
5	NC
6	DVI_clock
7	DVI_data
8	NC
9	DVI 1-
10	DVI 1+
11	GND
12	NC
13	NC
14	VCC
15	GND
16	DVI HPD
17	DVI 0-
18	DVI 0+
19	GND
20	NC
21	NC
22	GND
23	DVI_Clock+
24	DVI_Clock-
C1	NC
C2	NC
C3	NC
C4	NC
C5	NC

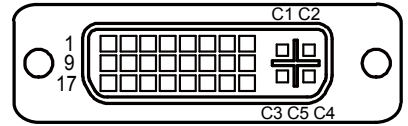

**DVI1**

## 2-10. DIGITAL I/O CONNECTOR

**DIO1:** Digital I/O Connector.

The pin assignments are as follows:

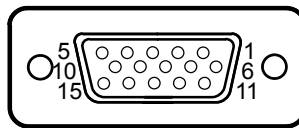

**DIO1**

PIN	ASSIGNMENT	PIN	ASSIGNMENT
1	DIN0	2	GND
3	DIN1	4	GND
5	DIN2	6	V5_SB
7	DIN3	8	GND
9	DOUT0	10	GND
11	DOUT1	12	GND
13	DOUT2	14	GND
15	DOUT3		

**JDIO1:** Digital I/O Connector.

The pin assignments are as follows:

PIN	ASSIGNMENT	PIN	ASSIGNMENT
1	V5_SB	2	GND
3	DIN1	4	DOUT1
5	DIN2	6	DOUT2
7	DIN3	8	DOUT3
9	DIN4	10	DOUT4

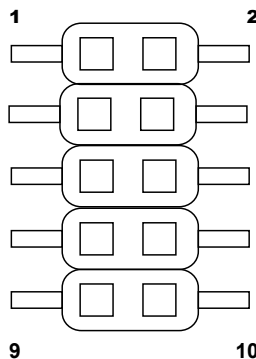

**JDIO1**

## 2-11. AUDIO CONNECTOR

### JAUDIO1: Audio Connectors

The pin assignments are as follows:

PIN	ASSIGNMENT
1	MIC1L
2	MIC1R
3	GND
4	GND
5	LINEINL
6	LINEINR
7	GND
8	GND
9	LINEOUTL
10	LINEOUTR



## 2-12. SATA & SATA POWER CONNECTOR

**SATA1:** Serial ATA Connector

The pin assignments are as follows:

PIN	ASSIGNMENT
1	GND
2	TX+
3	TX-
4	GND
5	RX-
6	RX+
7	GND

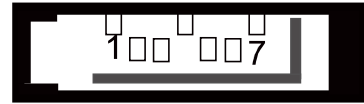

**SATA1**

**HDD\_Power1:** Serial ATA Power Connector

The pin assignments are as follows:

PIN	ASSIGNMENT
1	VCC5V
2	GND

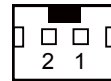

**HDD\_POWER1**

## 2-13. LVDS CONNECTOR

**LVDS1:** LVDS Connector

The pin assignments are as follows:

PIN	ASSIGNMENT	PIN	ASSIGNMENT
1	+3.3V/+5V	2	GND
3	LVDS_CLKBM	4	LVDS_CLKBP
5	GND	6	LVDS_YBM2
7	LVDS_YBP2	8	GND
9	LVDS_YBM1	10	LVDS_YBP1
11	LVDS_YBP3	12	LVDS_YBM3
13	LVDS_YBP0	14	LVDS_YBM0
15	GND	16	LVDS_CLKAP
17	LVDS_CLKAM	18	GND
19	LVDS_YAP2	20	LVDS_YAM2
21	GND	22	LVDS_YAP1
23	LVDS_YAM1	24	GND
25	LVDS_YAP0	26	LVDS_YAM0
27	LVDS_YAP3	28	LVDS_YAM3
29	+3.3V/+5V	30	+3.3V/+5V

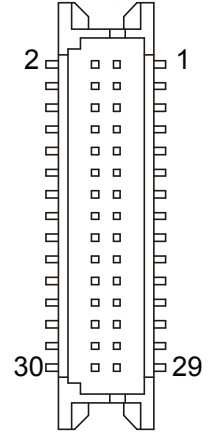

**LVDS1**



## 2-14. INVERTER CONNECTOR

**INV1:** Inverter Connector

The pin assignments are as follows:

PIN	ASSIGNMENT	PIN	ASSIGNMENT
1	V5P0A	2	V5P0A
3	USB_DM	4	VCC12
5	USB_DN	6	VCC12
7	GND	8	VCC12
9	INV_EN	10	VCC12
11	NC	12	VCC12
13	NC	14	HDD_LED
15	GND	16	PWR_LED
17	GND	18	Backlight PWM
19	VCC5	20	NC

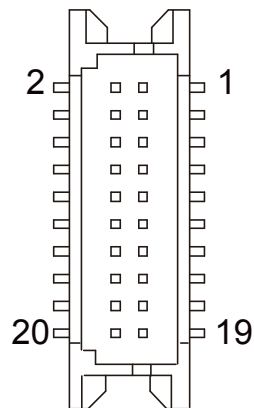

**INV1**

## 2-15. Backlight Level Selection Connector

**JP\_BLEN1:** Backlight Level Selection Connector

The selections are as follows:

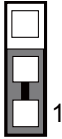
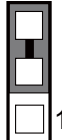

SELECTION	JUMPER SETTING	JUMPER ILLUSTRATION
3.3V (Default)	1-2	 <p><b>JP_BLEN1</b></p>
5V	2-3	 <p><b>JP_BLEN1</b></p>

**Note:** Manufacturing default is 3.3V.

## 2-16. Clear CMOS DATA SELECTION

**JP2:** Clear CMOS Data Selection Connector

The selections are as follows:

SELECTION	JUMPER SETTINGS	JUMPER ILLUSTRATION
Normal (default)	X	 <b>JP2</b>
Clear CMOS	1-2	 <b>JP2</b>

**Note:** Manufacturing Default is normal

## 2-17. Panel Resolution Selection

### JP4, JP5: Panel Resolution Selection Connectors

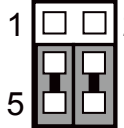
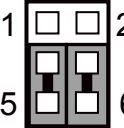
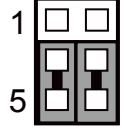
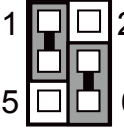
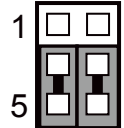
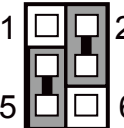
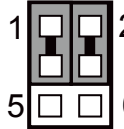
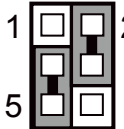

The selections are as follows:

Panel Resolution	Bit	Jumper Setting	JP4	JP5
800x600	6	JP4: 4-6,3-5 JP5: 4-6,3-5		
1024x768	6	JP4: 4-6,3-5 JP5: 4-6,1-3		
1024x768	8	JP4: 4-6,3-5 JP5: 2-4,3-5		
1920x1080	8	JP4: 2-4,3-1 JP5: 2-4,3-5		

## 2-18. LVDS VCC Selection

### JP6: LVDS VCC Selection

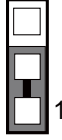
The selections are as follows:

SELECTION	JUMPER SETTING	JUMPER ILLUSTRATION
3.3V (Default)	1-2	 <b>JP6</b>
5V	2-3	 <b>JP6</b>

**Note:** Manufacturing default is 3.3V.

## 2-19. DVI-D ENABLE SELECTION

### JP34/JP35: DVI-D Enable Selection

The selections are as follows:

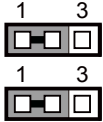
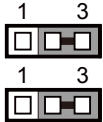

SELECTION	JUMPER SETTING	JUMPER ILLUSTRATION
DVI-D Enable (Default)	1-2	 <p><b>JP34/JP35</b></p>
DVI-D Disable	2-3	 <p><b>JP34/JP35</b></p>

**Note:** Manufacturing Default is DVI-D Enable

## 2-20. DVI-D HPD ENABLE SELECTION

### JP37: DVI-D HPD Enable Selection

The selections are as follows:

SELECTION	JUMPER SETTING	JUMPER ILLUSTRATION
DVI-D HPD Enable (default)	1-2	 <p><b>JP37</b></p>
DVI-D HPD Disable	1-x	 <p><b>JP37</b></p>

**Note:** Manufacturing Default is DVI-D HPD Enable

## 2-21. POWER MODE SELECTION

### JP39: Power Mode Selection

The selections are as follows:

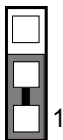
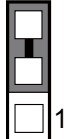
SELECTION	JUMPER SETTING	JUMPER ILLUSTRATION
AT Mode	1-2	 <p><b>JP39</b></p>
ATX Mode (Default)	2-3	 <p><b>JP39</b></p>

**Note:** Manufacturing default is ATX Mode.

## 2-22. DDC SELECTION

### JP13: DDC Selection

The selections are as follows:

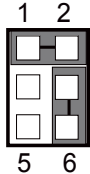
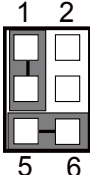
SELECTION	JUMPER SETTING	JUMPER ILLUSTRATION
VGA DDC	1-2 4-6	 <p><b>JP13</b></p>
DVI-I DDC	1-3 5-6	 <p><b>JP13</b></p>

- Note:**
1. Manufacturing default is DVI-I DDC.
  2. Please set JP13 to VGA DDC if connecting VGA & DVI-D as dual display.



# ***SOFTWARE UTILITIES***

## **CHAPTER 3**

This chapter comprises the detailed information of VGA driver, LAN driver, Sound driver and Card Reader driver.

The following sections are included:

- Introduction
- Intel® Chipset Software Installation Utility
- Intel® Trusted Execution Engine Driver installation
- Intel® Kernel-Mode Driver Framework Driver installation
- Intel® Mailbox Interface Device Driver installation
- VGA Driver Utility
- LAN Driver Utility
- SOUND Driver Utility
- CARD READER Driver Utility
- For USB3.0 Driver installation

### 3-1. INTRODUCTION

Enclosed with our SE-8124 package, you will find a DVD ROM disk containing all types of drivers we have. As a SE-8124 user, you will only need some of files contained in the DVD ROM disk, please take note of the following chart:

<b>FILENAME (Assume that DVD ROM drive is D :)</b>	<b>PURPOSE</b>
D:\Driver\Platform\Win7, Win8.1(32-bit)\Main Chip or D:\Driver\Platform\Win7, Win8.1(64-bit)\Main Chip	Intel ® Chipset Software Installation Utility
D:\Driver\Platform\ Win7, Win8.1 (32-bit)\TXE or D:\Driver\Platform\ Win7, Win8.1(64-bit)\TXE	Intel ® Trusted Execution Engine Driver installation
D:\Driver\Platform\Win7(32/64-bit)\KMDF	Intel ® Kernel-Mode Driver Framework Driver installation
D:\Driver\Platform\Win8.1 (32/64-bit)\MBI	Intel® Mailbox Interface Device Driver installation
D:\Driver\Platform\ Win7, Win8.1 (32-bit)\VGA or D:\Driver\Platform\ Win7, Win8.1(64-bit)\VGA	Intel ® Atom™ Processor E3800 Series Driver installation
D:\Driver\Platform\ Win7, Win8.1 (32-bit)\LAN or D:\Driver\Platform\ Win7, Win8.1(64-bit)\LAN	WGI210IT Intel® Springville GbE Controller for LAN Driver installation
D:\Driver\Platform\ Win7, Win8.1 (32-bit)\Sound or D:\Driver\Platform\ Win7, Win8.1(64-bit)\Sound	Realtek ® ALC888S for Sound Driver installation
D:\Driver\Device\Platform\Win7(32/64-bit)\USB3.0	For USB3.0 Driver installation
D:\Driver\Device	Driver installation for Card Reader, wireless, 3G, etc.
D:\Driver\FLASH	Driver installation for BIOS update utility (AMI)

**Note:** Be sure to install the Utility right after the OS is fully installed.

## **3-2. INTEL® CHIPSET SOFTWARE INSTALLATION UTILITY**

### **3-2-1. Introduction**

The Intel® Chipset Device Software installs Windows \*.INF files to the target system. These files outline to the operating system how to configure the Intel® chipset components in order to ensure that the following features function properly:

- PCIe Support
- SATA Storage Support
- USB Support
- Identification of Intel® Chipset Components in the Device Manager

### **3-2-2. Installation of Utility for Windows 7/ 8.1**

The Utility Pack is made only for Windows 7/ 8.1. It should be installed right after the OS installation; kindly follow the following steps:

1. Place insert the Utility Disk into Floppy Disk Drive A/B or DVD ROM drive.
2. Under Windows system, go to the directory where Utility Disc is located.  
e.g.: \DRIVER\UTILITY\infinst\_autol.exe
3. Click infinst\_autol.exe file for utility installation.
4. Follow the instructions on the screen to complete the installation.
5. Once installation is completed, shut down the system and restart in order for the changes to take effect.

## **3-3. INTEL® TRUSTED EXECUTION ENGINE DRIVER INSTALLATION**

### **3-3-1. Introduction**

The Intel® ME software components that need to be installed depend on the system's specific hardware and firmware features. The installer, compatible with Windows 7/ 8.1, detects the system's capabilities and installs the relevant drivers and applications.

### **3-3-2. Installation Instructions for Windows 7/ 8.1**

1. Insert the driver disk into a DVD ROM device.
2. Under Windows system, go to the directory where the driver is located.
3. Run the application with administrative privileges.

## **3-4. INTEL ® KERNEL-MODE DRIVER FRAMEWORK DRIVER INSTALLATION**

### **3-4-1. Introduction**

The Intel ® Kernel-Mode Driver Framework Driver that needs to be installed depends on the system's specific hardware and firmware features. The installer, compatible with Windows 7/ 8.1, detects the system's capabilities and installs the relevant drivers and applications.

### **3-4-2. Installation Instructions for Windows 7**

To install the utility, simply follow the following steps:

1. Insert the driver disk into a DVD ROM device.
2. Under Windows system, go to the directory where the driver is located.
3. Run the application with administrative privileges.

## **3-5. INTEL® MAILBOX INTERFACE DEVICE DRIVER**

### **3-5-1. Introduction**

The Intel® Mailbox Interface Device Driver is a bridge to the Intel Dynamic Platform and Thermal Framework. It needs to be installed depend on the system's specific hardware and firmware features. The installer, compatible with Windows 8.1, detects the system's capabilities and installs the relevant drivers and applications. The driver supports the following Intel® Chipsets/Processors:

- Intel® Bay Trail –M Platforms with ValleyView2 SOC.

### **3-5-2. Installation Instructions for Windows 8.1**

To install the utility, simply follow the following steps:

4. Insert the driver disk into a DVD ROM device.
5. Under Windows system, go to the directory where the driver is located.
6. Run the application with administrative privileges.

## **3-6. INTEL<sup>®</sup> USB3.0 EXTENSIBLE HOST CONTROLLER UTILITY**

### **3-6-1. Introduction**

Intel<sup>®</sup> USB 3.0 eXtensible Host Controller Driver supports the following Intel<sup>®</sup> Chipsets/Processors:

- Intel<sup>®</sup> 4<sup>th</sup> Generation Core™ Processor Family
- Intel<sup>®</sup> 8 Series/C220 Series Chipset Family
- Intel<sup>®</sup> 4<sup>th</sup> Generation U-Series Platform I/O

### **3-6-2. Installation Instructions for Windows 7**

To install the utility, simply follow the following steps:

7. Insert the driver disk into a DVD ROM device.
8. Under Windows system, go to the directory where the driver is located.
9. Run the application with administrative privileges.

### **3-7. VGA DRIVER UTILITY**

The VGA interface is embedded with our SE-8124 system to support CRT display. The following illustration briefly shows you the content of VGA driver in D:\Driver\VGA.

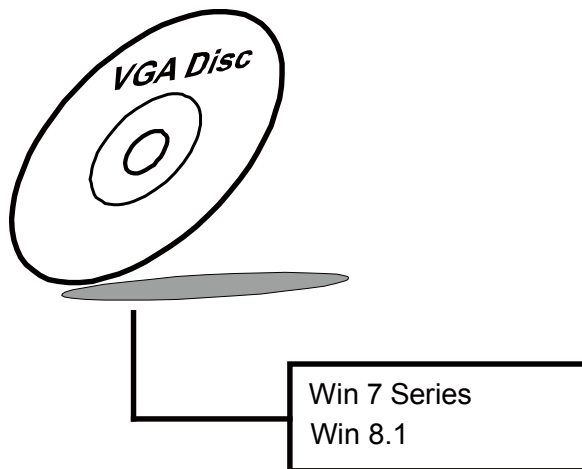

#### **3-7-1. Installation of VGA Driver**

1. Start the computer (Win 7).
2. Insert the Utility Disk into the DVD ROM drive or drive A/B.
3. Open the VGA folder for your system to choose an appropriate folder, and double-click "exe" file to install. e.g. d:\DRIVER\VGA\Your system\\*\*\*.exe (If D is not your DVD-ROM drive, substitute D with the correct drive letter.)
4. Follow the Wizard's on-screen instructions to complete the installation.



### 3-8 LAN DRIVER UTILITY

The SE-8124 is enhanced with LAN function that can support various network adapters. The content of the LAN driver is found as follows:

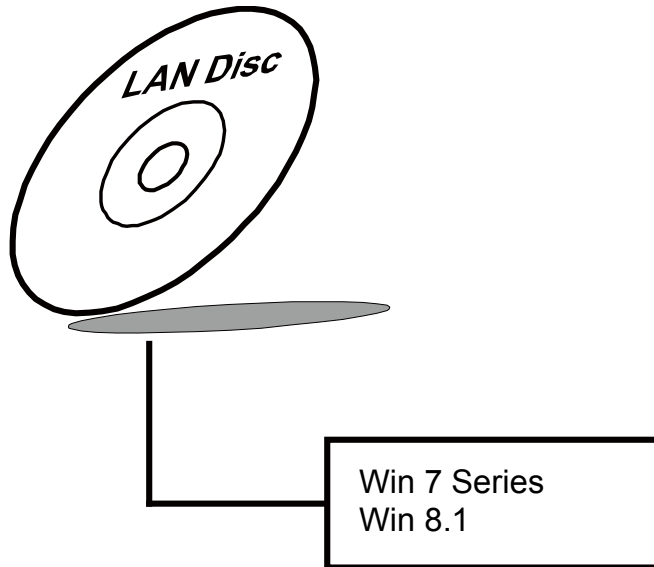

**For more details on Installation procedure, please refer to Readme.txt file found on LAN DRIVER UTILITY.**

## **3-9. SOUND DRIVER UTILITY**

### **3-9-1. Introduction**

The Audio chip enhanced in this system is fully compatible with Windows 7/ 8.1. Below, you will find the content of the Sound driver:

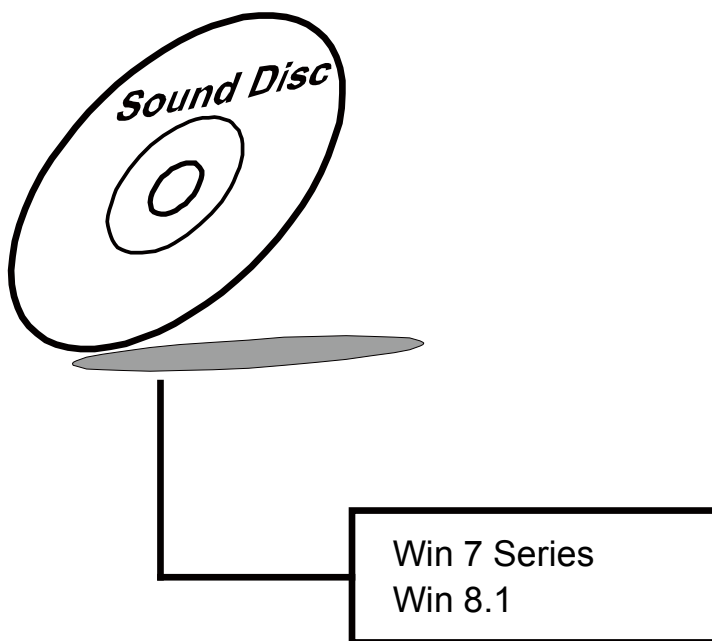

### **3-9-2. Installation Procedure for Windows 7/ 8.1**

1. Open the SOUND folder. For your system to choose an appropriate folder, and Run the setup.exe program to start the installation. e.g. :\`DRIVER\SOUND\Your system\setup.exe`
2. (If D is not your DVD-ROM drive, substitute D with the correct drive letter.)
3. Click on [Next] to continue the procedure. If the Windows popup "Windows can't verify the publisher of this driver software" message, press "Install this driver software anyway" to continue the installation.
4. Finally, select to restart the system and press [Finish] to complete the installation.

### **3-10. Installing Card Reader Driver Utility**

The card reader driver utility can be installed on Windows 7, and it should be installed right after the OS installation.

To install the card reader driver, follow the steps below:

1. Open the **Device/Card Reader** folder where the card reader driver is located.
2. Click **Install Intel Processor Win7 IO Drivers 64Bit. msi** (or **Install Intel Processor Win7 IO Drivers 32Bit.msi**) file for driver installation on Win7 64-bit (or 32-bit).
3. Follow the on-screen instructions to complete the installation.
4. Once the installation is completed, shut down the system and restart it for the changes to take effect.
5. Open the **Device/Card Reader** folder and click the hotfix driver **Windows6.1-KB2732471-v2-x64.msu** on Win 7/WES7 64 bit after you restart the system.

**Note:** Execute Windows on-line update after the card reader driver installation is finished on WES7.

# ***SYSTEM INSTALLATION***

*CHAPTER*

**4**

This chapter shows how to install system for SE-8124.

Section includes:

- Removing the bottom case
- HDD Installation
- SO-DIMM Installation
- Wireless LAN or 3G module Installation
- PoE Board Installation

## 4.1 Removing the bottom case

### **Caution:**

Please make sure the system is powered off and disconnected from the power sources before removing the bottom case to prevent electric shock or system damage.

1. Locate the 6 screws on the bottom case

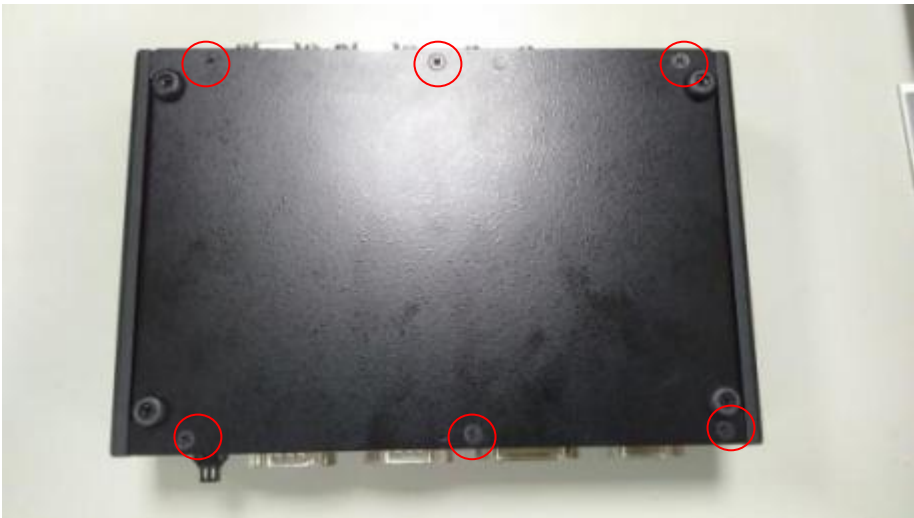

2. Remove the 6 screws on the bottom case

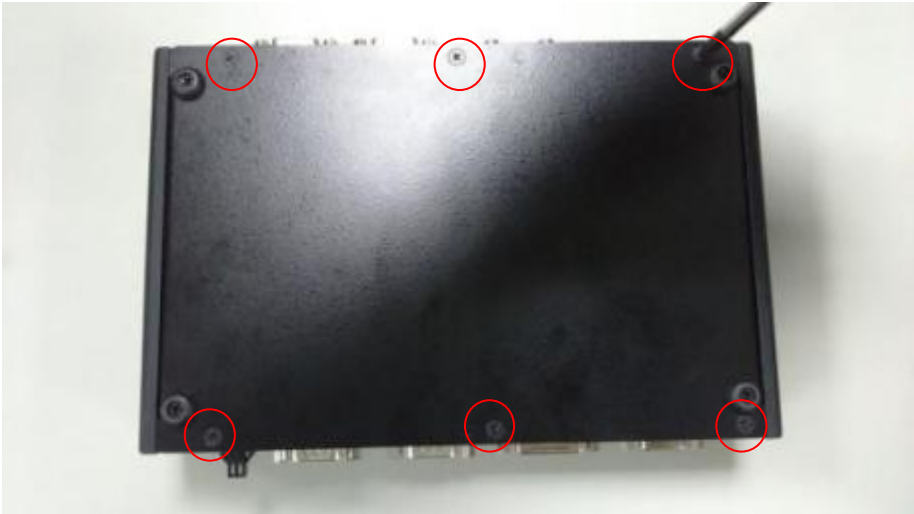

3. Remove the bottom case



## 4.2 HDD Installation

1. Remove the bottom case



2. Remove the 2 screws of HDD drive bay

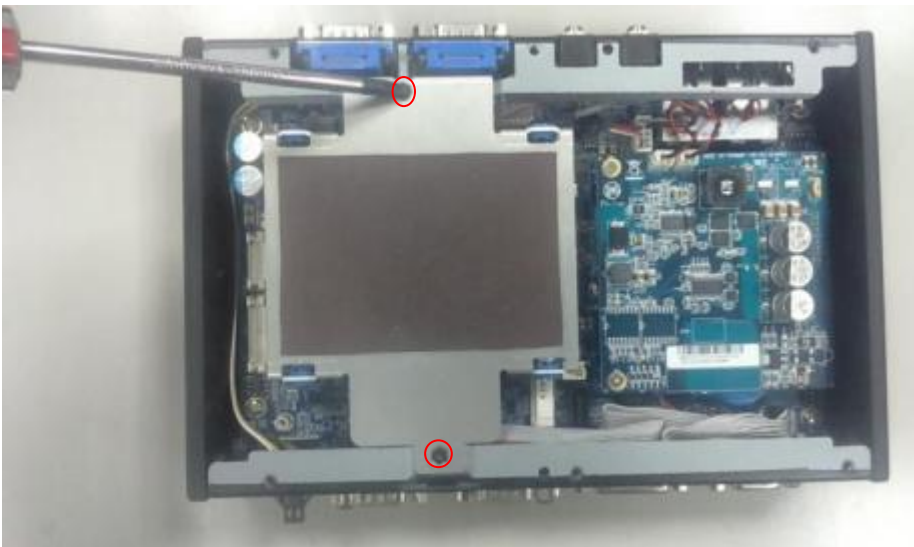

3. Paste thermal pad on HDD PCB (drive bay side)



4. Put the HDD on the drive bay correctly





5. Fasten 4 HDD screws to fix HDD on the drive bay

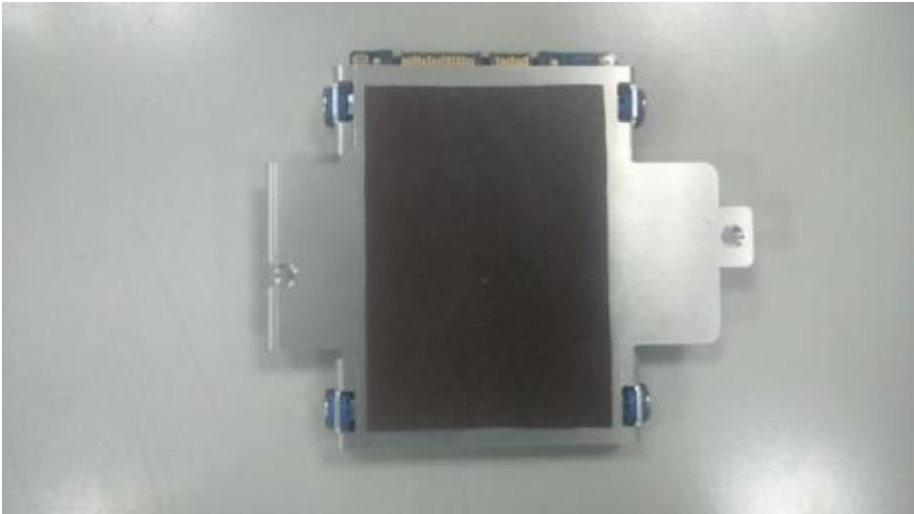

6. Plug SATA & HDD power cables on the motherboard



7. Plug SATA & HDD power cable into HDD and put HDD & drive bay on the chassis



8. Fasten the 2 screws of HDD drive bay



### 4.3 SO-DIMM Installation

1. Remove the bottom case

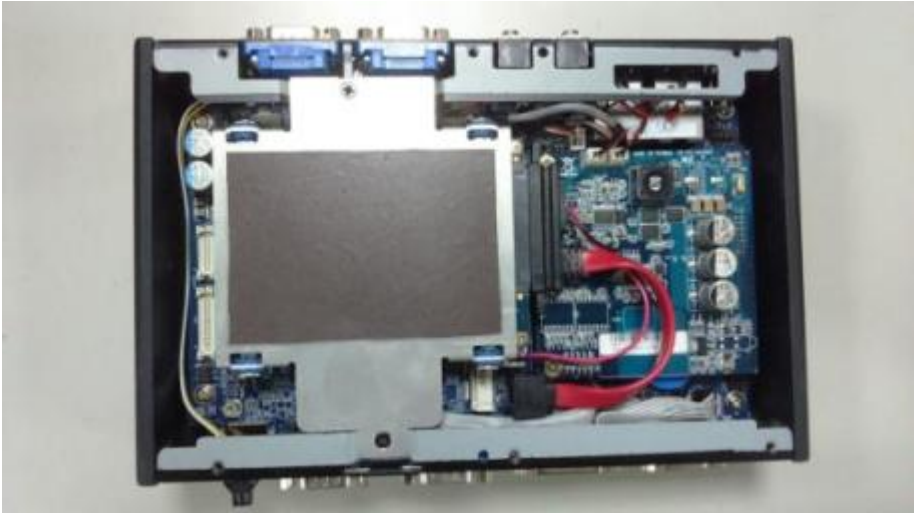

2. Remove the 2 screws & SATA/power cables of HDD drive bay

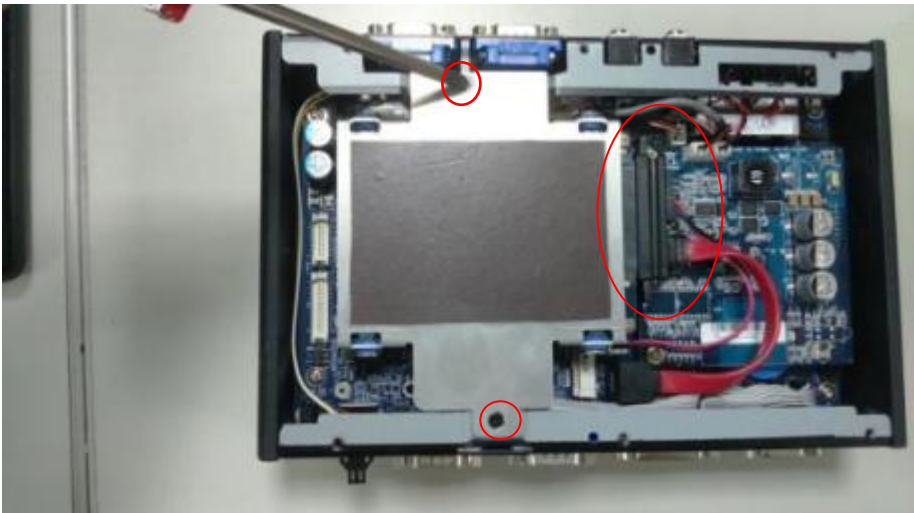

3. Remove SATA/power cables on the mother board



4. Locate the SO-DIMM socket



5. Prepare SO-DIMM and SO-DIMM heatsinks



6. Paste SO-DIMM heatsinks on the 2 sides of SO-DIMM



7. Insert the SO-DIMM into the socket at 20~30 degrees angle



8. Gently push the rear of the SO-DIMM down until it's clipped into place and secure the SO-DIMM in the socket.



## **4.4 Wireless LAN or 3G module Installation**

### **A. Full-size mini-PCIe slot**

1. If a half-size mini-PCIe module, connect it with half-size to full-size mini-PCIe bracket by 2 screws before installation



2. Locate the full size mini-PCIe slot



3. Insert the mini-PCIe module into the full-size mini-PCIe slot



Figure 3a. Half-size mini-PCIe module



Figure3b. Full-size mini-PCIe module



4. Fasten the 2 screws of full-size mini-PCIe slot



Figure 4a. Half-size mini-PCIe module



Figure 4b. Half-size mini-PCIe module

**B. Half-size mini-PCIe slot**

1. Locate the half size mini-PCIe slot



2. Insert the mini-PCIe module into the half-size mini-PCIe slot



3. Fasten the 2 screws of half-size mini-PCIe slot



## 4.5. PoE Board Installation

1. Connect the PoE LED cable on PoE board



2. Put PoE board right on the PoE connector



3. Fasten 2 screws of PoE board



# *AMI*

## *BIOS SETUP*

*CHAPTER*

**5**

This chapter describes how to set up the AMI BIOS.

The following topics are included:

- Introduction
- Accessing Setup
- Main
- Advanced
- Chipset
- Security
- Boot
- Save & Exit

## 5.1 Introduction

The board **SE-8124** uses an AMI Aptio BIOS that is stored in the Serial Peripheral Interface Flash Memory (SPI Flash) and can be updated. The SPI Flash contains the BIOS Setup program, Power-On Self-Test (POST), the PCI auto-configuration utility, LAN EEPROM information, and Plug and Play support.

Aptio is AMI's BIOS firmware based on the UEFI (Unified Extensible Firmware Interface) Specifications and the Intel Platform Innovation Framework for EFI. The UEFI specification defines an interface between an operating system and platform firmware. The interface consists of data tables that contain platform-related information, boot service calls, and runtime service calls that are available to the operating system and its loader. These provide standard environment for booting an operating system and running pre-boot applications. Following illustration shows Extensible Firmware Interface's position in the software stack.

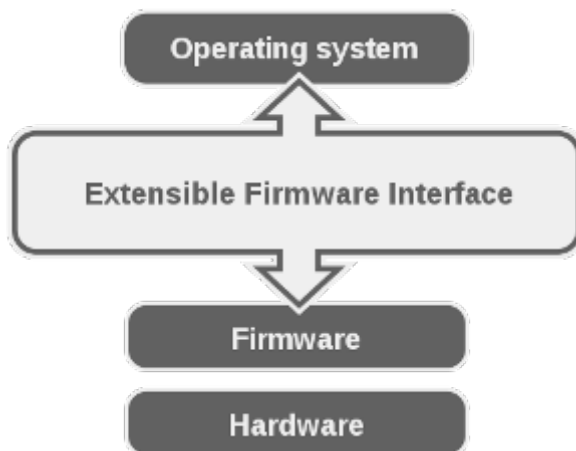

EFI BIOS provides an user interface allow users the ability to modify hardware configuration, e.g. change system date and time, enable or disable a system

component, decide bootable device priorities, setup personal password, etc., which is convenient for modifications and customization of the computer system and allows technicians another method for finding solutions if hardware has any problems.

The BIOS Setup program can be used to view and change the BIOS settings for the computer. The BIOS Setup program is accessed by pressing the <Del> or <ESC> key after the POST memory test begins and before the operating system boot begins. The settings are shown below.



## **5.2 Accessing Setup**

When the system is powered on, the BIOS will enter the Power-On Self-Test (POST) routines and the following message will appear on the lower screen:



### **BIOS POST Screen**

As long as this message is present on the screen you may press the <Del> key to access the Setup program. In a moment, the main menu of the Aptio Setup Utility will appear on the screen.

The **Main** menu screens of Bay Trail-D and Bay Trail-I platforms are shown respectively as below:



**For Bay Trail-D Platform**



### **For Bay Trail-I Platform**

#### **Setup program initialization screen**

You may move the cursor by up/down keys to highlight the individual menu items. As you highlight each item, a brief description of the highlighted selection will appear at the bottom of the screen.

## 5.3 Main

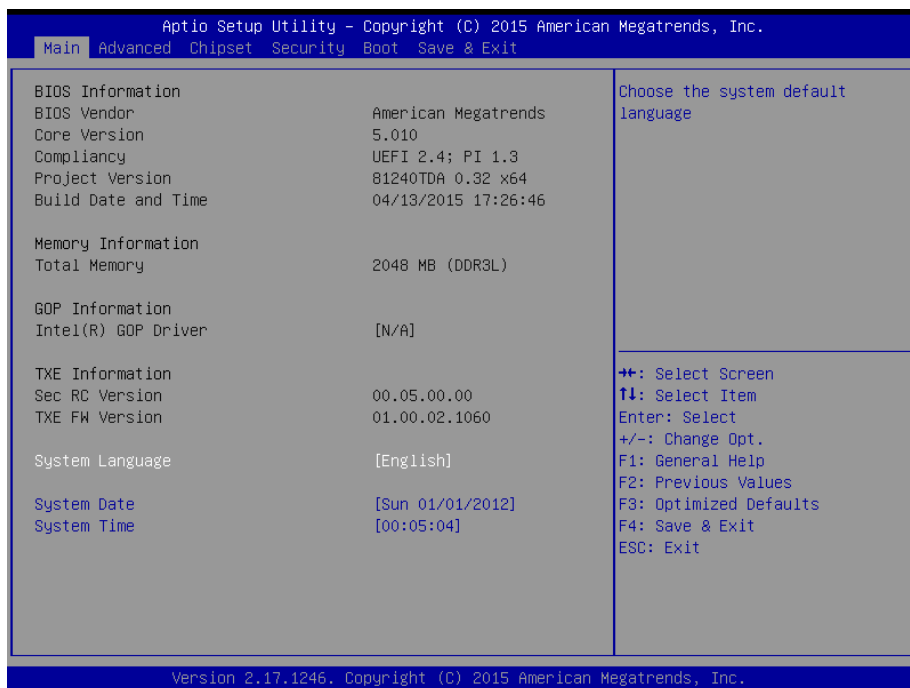

## Main Screen

BIOS Setting	Options	Description/Purpose
BIOS Vendor	No changeable options	Displays the BIOS vendor.
Core Version	No changeable options	Displays the current BIOS core version.
Compliancy	No changeable options	Displays the current UEFI version.
Project Version	No changeable options	Displays the version of the BIOS currently installed on the platform.
Build Date and Time	No changeable options	Displays the date of current BIOS version.
Total Memory	No changeable options	Displays the memory size.
Intel(R) GOP Driver	No changeable options	Displays the GOP driver version.
Sec RC Version	No changeable options	Displays the current Sec RC version.
TXE Firmware Version	No changeable options	Displays the current TXE Version
System Language	English	BIOS Setup language.
System Date	month, day, year	Specifies the current date.

BIOS Setting	Options	Description/Purpose
System Time	hour, minute, second	Specifies the current time.

## 5.4 Advanced

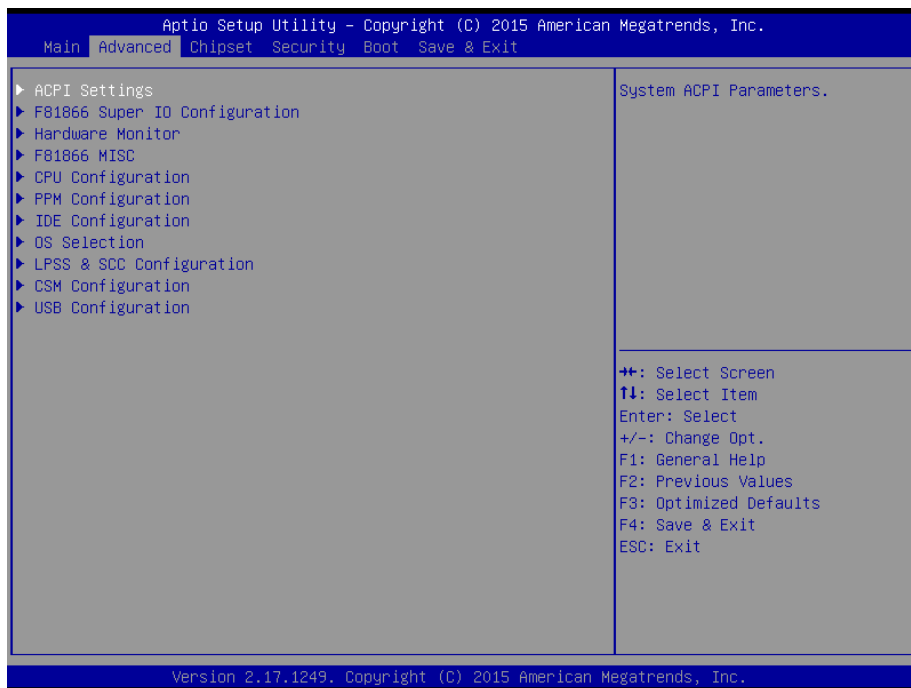

### Advanced Screen

BIOS Setting	Options	Description/Purpose
ACPI Settings	Sub-Menu	System ACPI Parameters.
F81866 Super IO Configuration	Sub-Menu	System Super IO Chip Configuration.
Hardware Monitor	Sub-Menu	Monitor hardware status
F81866 MISC	Sub-Menu	F81866 related functions.
CPU Configuration	Sub-Menu	CPU Configuration. Parameters.
PPM Configuration	Sub-Menu	PPM Configuration. Parameters.
IDE Configuration	Sub-Menu	SATA Configuration Parameters.

<b>BIOS Setting</b>	<b>Options</b>	<b>Description/Purpose</b>
OS Selection	Sub-Menu	OS selection settings.
LPSS & SCC Configuration	Sub-Menu	LPSS & SCC Configuration Setting
CSM Configuration	Sub-Menu	Configures Option ROM execution, boot options filters, etc.
USB Configuration	Sub-Menu	USB Configuration Parameters.

## 5.4.1 Advanced – ACPI Settings

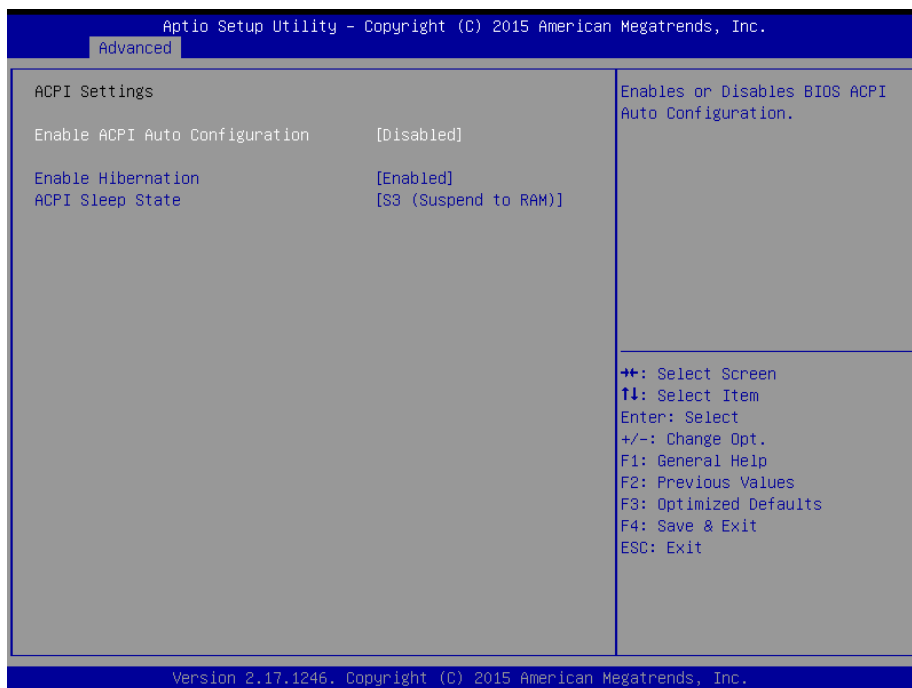

## ACPI Settings Screen

BIOS Setting	Options	Description/Purpose
Enable ACPI Auto Configuration	- Disabled - Enabled	Enables or Disables ACPI feature.
Enable Hibernation	- Disabled - Enabled	Enables or Disables System ability to Hibernate (OS/S4 Sleep State). This option may be not effective with some OS.
ACPI Sleep State	- Suspend Disabled - S3 Only (Suspend to RAM)	Specifies the ACPI sleep state. <b>Suspend Disabled</b> disables ACPI sleep feature. <b>S3</b> allows the platform to enter Suspend to RAM mode.

## 5.4.2 Advanced – F81866 Super IO Configuration

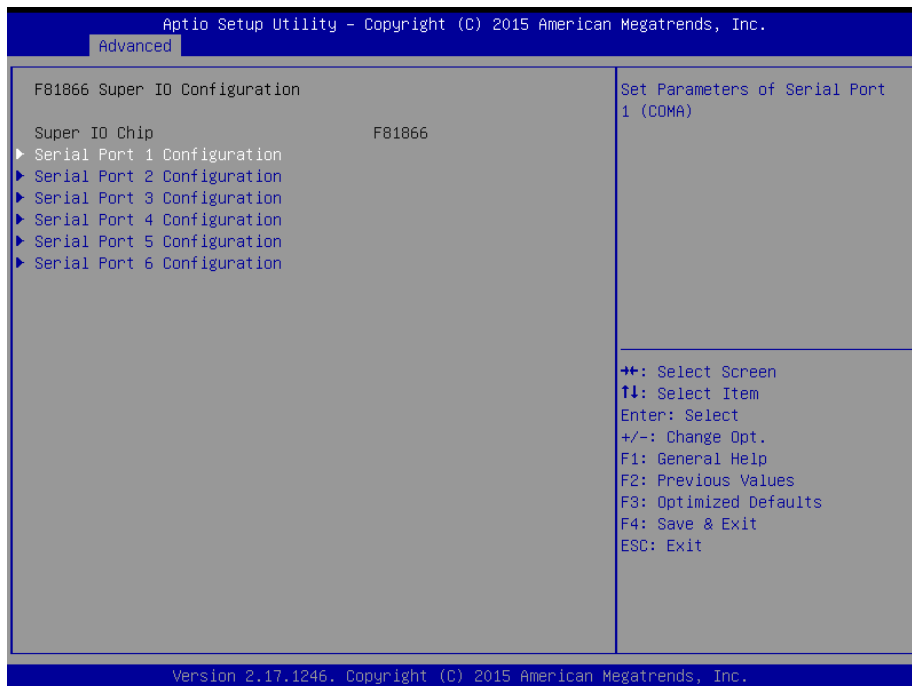

## F81866 Super IO Configuration Screen

BIOS Setting	Options	Description/Purpose
Super IO Chip	No changeable options	Displays the super IO chip model and its manufacturer.
Serial Port 1 Configuration	Sub-menu	Sets Parameters for COMA.
Serial Port 2 Configuration	Sub-menu	Sets Parameters for COMB.
Serial Port 3 Configuration	Sub-menu	Sets Parameters for COMC.
Serial Port 4 Configuration	Sub-menu	Sets Parameters for COMD.



<b>BIOS Setting</b>	<b>Options</b>	<b>Description/Purpose</b>
Serial Port 5 Configuration	Sub-menu	Set Parameters for COME
Serial Port 6 Configuration	Sub-menu	Set Parameters for COMF

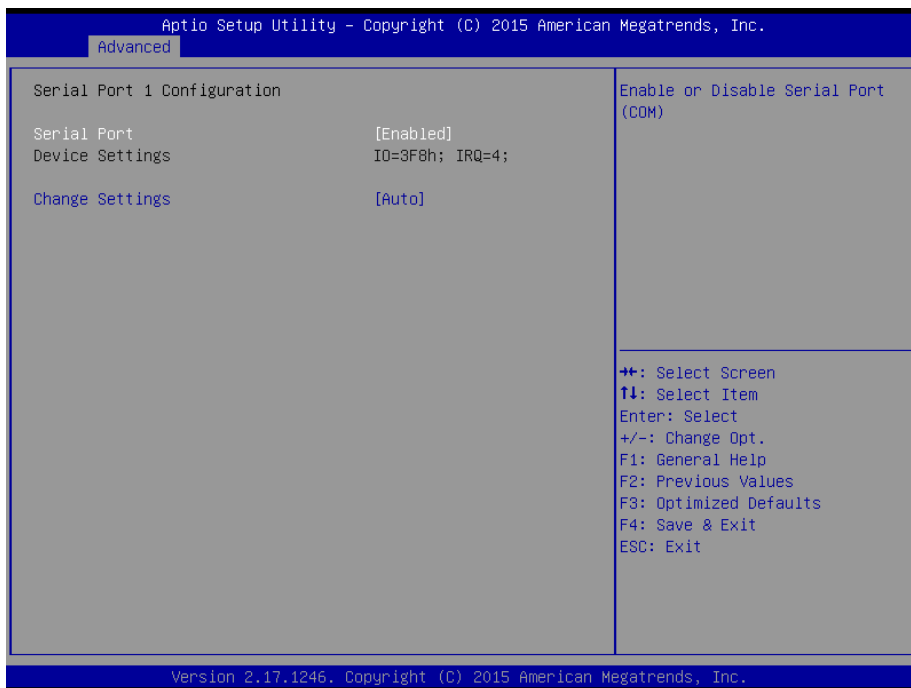

### Serial Port 1 Configuration Screen

BIOS Setting	Options	Description/Purpose
Serial Port	- Disabled - Enabled	Enables or disables serial port 1.
Device Settings	No changeable options	Displays the current settings of serial port 1.
Change Settings	- Auto - IO=3F8h; IRQ=4 - IO=3F8h; IRQ=3,4,5,6,7,9,10,11,12 - IO=2F8h; IRQ=3,4,5,6,7,9,10,11,12 - IO=3E8h; IRQ=3,4,5,6,7,9,10,11,12 - IO=2E8h; IRQ=3,4,5,6,7,9,10,11,12	Selects IRQ and I/O resource settings for the serial port 1.



### Serial Port 2 Configuration Screen

BIOS Setting	Options	Description/Purpose
Serial Port	- Disabled - Enabled	Enables or disables serial port 2.
Device Settings	No changeable options	Displays the current settings of serial port 2.
Change Settings	- Auto - IO=2F8h; IRQ=3 - IO=3F8h; IRQ=3,4,5,6,7,9,10,11,12 - IO=2F8h; IRQ=3,4,5,6,7,9,10,11,12 - IO=3E8h; IRQ=3,4,5,6,7,9,10,11,12 - IO=2E8h; IRQ=3,4,5,6,7,9,10,11,12	Selects IRQ and I/O resource settings for the serial port 2.



### Serial Port 3 Configuration Screen

BIOS Setting	Options	Description/Purpose
Serial Port	- Disabled - Enabled	Enables or disables serial port 3.
Device Settings	No changeable options	Displays the current settings of serial port 3.
Change Settings	- Auto - IO=3E8h; IRQ=7 - IO=3F8h; IRQ=3,4,5,6,7,9,10,11,12 - IO=2F8h; IRQ=3,4,5,6,7,9,10,11,12 - IO=3E8h; IRQ=3,4,5,6,7,9,10,11,12 - IO=2E8h; IRQ=3,4,5,6,7,9,10,11,12	Selects IRQ and I/O resource settings for the serial port 3.

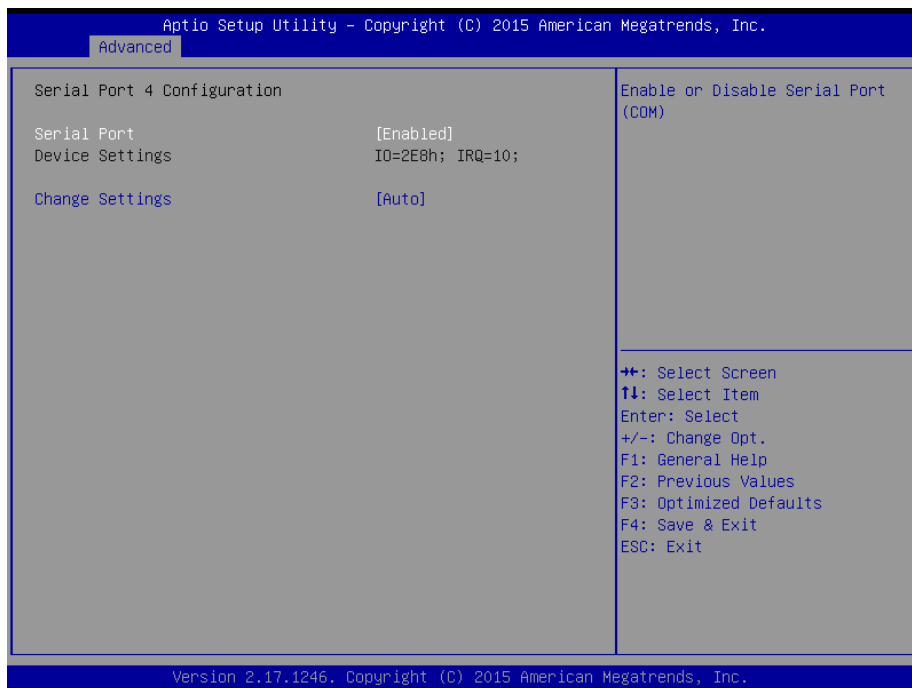

### Serial Port 4 Configuration Screen

BIOS Setting	Options	Description/Purpose
Serial Port	- Disabled - Enabled	Enables or disables serial port 5.
Device Settings	No changeable options	Displays the current settings of serial port 5.
Change Settings	- Auto - IO=2E8h; IRQ=10 - IO=3F8h; IRQ=3,4,5,6,7,9,10,11,12 - IO=2F8h; IRQ=3,4,5,6,7,9,10,11,12 - IO=3E8h; IRQ=3,4,5,6,7,9,10,11,12 - IO=2E8h; IRQ=3,4,5,6,7,9,10,11,12	Selects IRQ and I/O resource settings for the serial port 5.

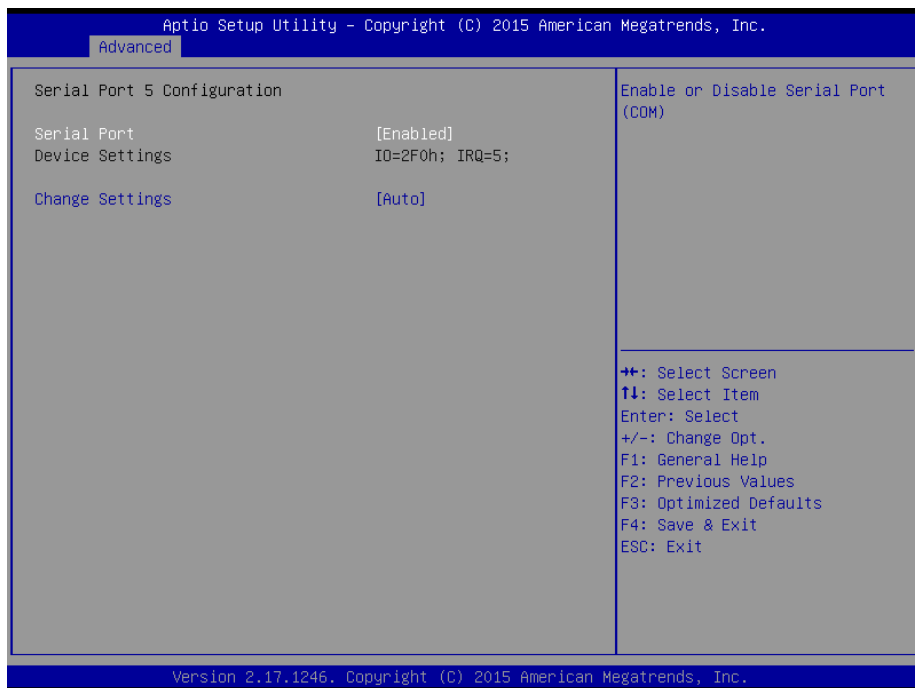

### Serial Port 5 Configuration Screen

BIOS Setting	Options	Description/Purpose
Serial Port	- Disabled - Enabled	Enables or disables serial port 5.
Device Settings	No changeable options	Displays the current settings of serial port 5.
Change Settings	- Auto - IO=2E8h; IRQ=5 - IO=3F8h; IRQ=3,4,5,6,7,9,10,11,12 - IO=2F8h; IRQ=3,4,5,6,7,9,10,11,12 - IO=3E8h; IRQ=3,4,5,6,7,9,10,11,12 - IO=2E8h; IRQ=3,4,5,6,7,9,10,11,12	Select IRQ and I/O resource settings for the serial port 5.

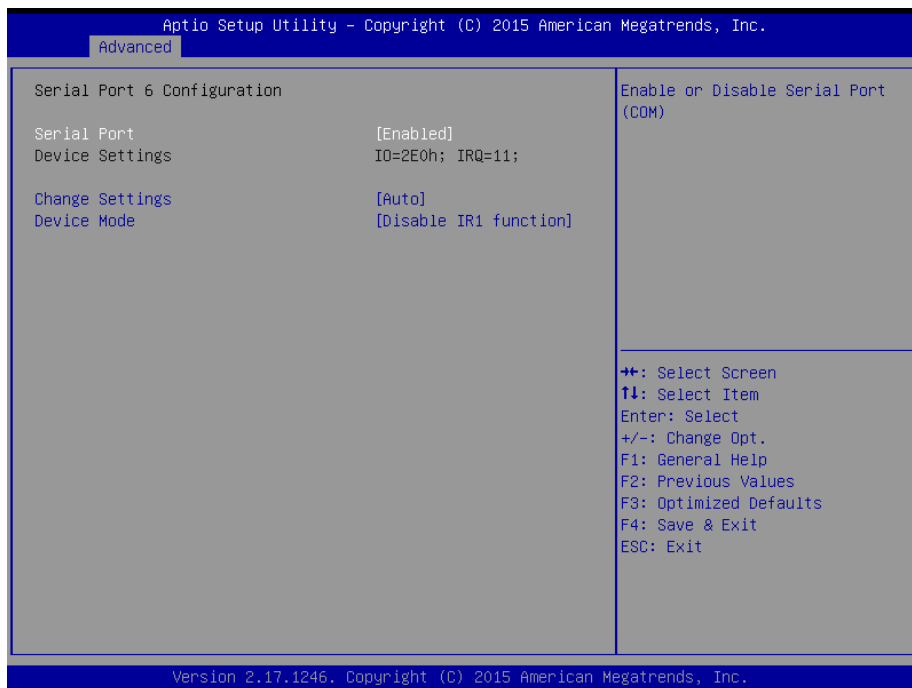

### Serial Port 6 Configuration Screen

BIOS Setting	Options	Description/Purpose
Serial Port	- Disabled - Enabled	Enables or disables serial port 6.
Device Settings	No changeable options	Displays the current settings of serial port 6
Change Settings	- Auto - IO=2E8h; IRQ=11 - IO=3F8h; IRQ=3,4,5,6,7,9,10,11,12 - IO=2F8h; IRQ=3,4,5,6,7,9,10,11,12 - IO=3E8h; IRQ=3,4,5,6,7,9,10,11,12 - IO=2E8h; IRQ=3,4,5,6,7,9,10,11,12	Select IRQ and I/O resource settings for the serial port 6.

## 5.4.3 Advanced – Hardware Monitor

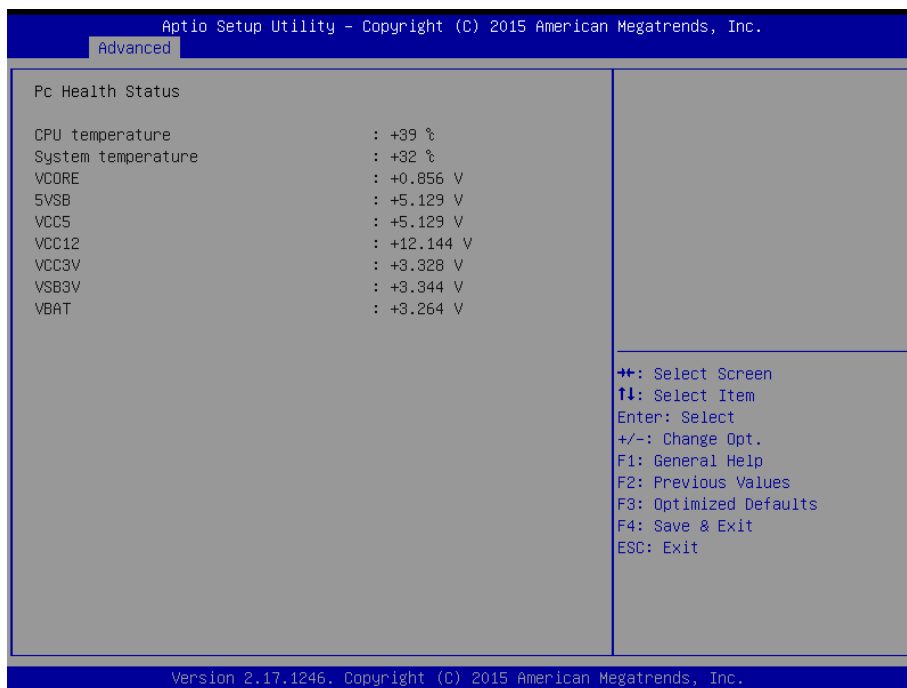

## Hardware Monitor Screen

BIOS Setting	Options	Description/Purpose
CPU temperature	No changeable options	Displays the processor's temperature.
System temperature	No changeable options	Displays the system's temperature.
VCORE	No changeable options	Displays the voltage level of the +VCORE in supply.
5VSB	No changeable options	Displays the voltage level of the +VSB5 in supply.
VCC5	No changeable options	Displays the voltage level of the +VCC5 in supply.



<b>BIOS Setting</b>	<b>Options</b>	<b>Description/Purpose</b>
VCC12	No changeable options	Displays the voltage level of the + VCC12 in supply.
VCC3V	No changeable options	Displays the voltage level of the + VCC3 in supply.
VSB3V	No changeable options	Displays the voltage level of the standby VCC3 in supply.
VBAT	No changeable options	Displays the voltage level of the battery in supply.

## 5.4.4 Advanced – F81866 MISC



## F81866 MISC Screen

BIOS Setting	Options	Description/Purpose
Enable WatchDog	-Disabled -Enabled	Enables/ Disables Watch dog timer.
Watch Dog timer unit	-1s - 60s	Sets the desired value seconds or minutes for watchdog timer.
Count for Timer (Seconds)	multiple options ranging from 1 to 255	Sets the desired value (seconds) for watchdog timer.
COM1 mode Selection	- RS232 - RS422 - RS485	Select RS232 or RS422 or RS485 for the COM1 port.
COM2 mode Selection	- RS232 - RS422 - RS485	Select RS232 or RS422 or RS485 for the COM2 port.

## 5.4.5 Advanced – CPU Configuration



## CPU Configuration Screen

BIOS Setting	Options	Description/Purpose
CPU Signature	No changeable options	Reports the CPU Signature
Socket 0 CPU Information	Sub-Menu	Report CPU Information
CPU Speed	No changeable options	Reports the current CPU Speed
64-bit	No changeable options	Reports if 64-bit is supported by the processor.
Limit CPUID Maximum	- Disabled - Enabled	Enables for legacy operating systems to boot processors with extended CPUID functions. Set disable for Win XP.

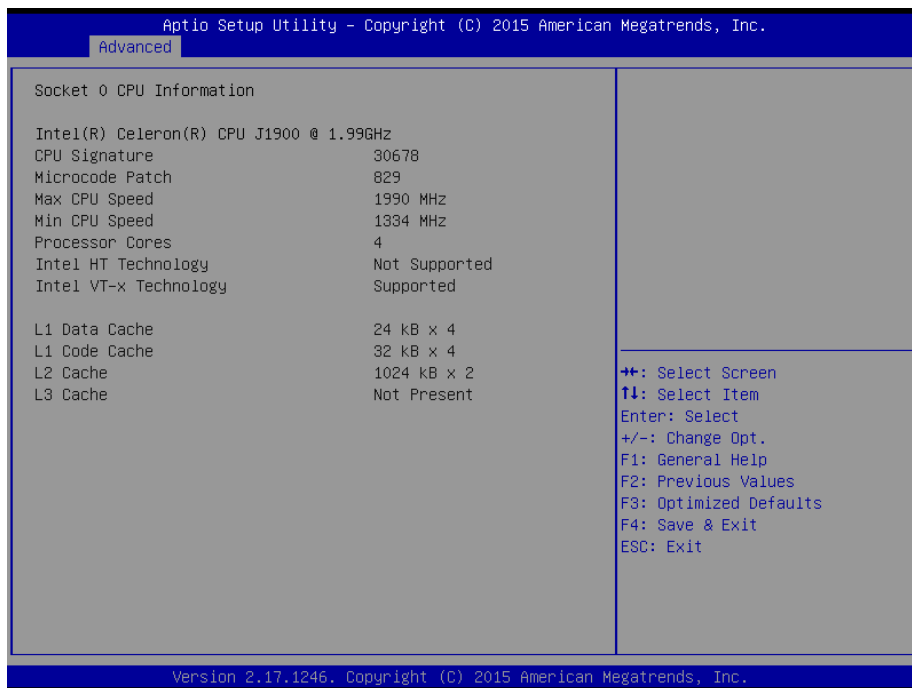

### Socket 0 CPU Information Screen

BIOS Setting	Options	Description/Purpose
CPU Signature	No changeable options	Reports the CPU Signature
Microcode Patch	No changeable options	Reports the CPU Microcode Patch Version.
Max CPU Speed	No changeable options	Reports the maximum CPU Speed.
Min CPU Speed	No changeable options	Reports the minimum CPU Speed
Processor Cores	No changeable options	Displays number of physical cores in the processor.
Intel HT Technology	No changeable options	Reports if Intel Hyper-Threading Technology is supported by the processor.
Intel VT-x Technology	No changeable options	Reports if Intel VT-x Technology is supported by the processor.
L1 Data Cache	No changeable options	Displays the size of L1 Data Cache.
L1 Code Cache	No changeable options	Displays the size of L1 Code Cache.
L2 Cache	No changeable options	Displays the size of L2 Cache.

<b>BIOS Setting</b>	<b>Options</b>	<b>Description/Purpose</b>
L3 Cache	No changeable options	Displays size of L3 Cache.

### 5.4.6 Advanced – PPM Configuration

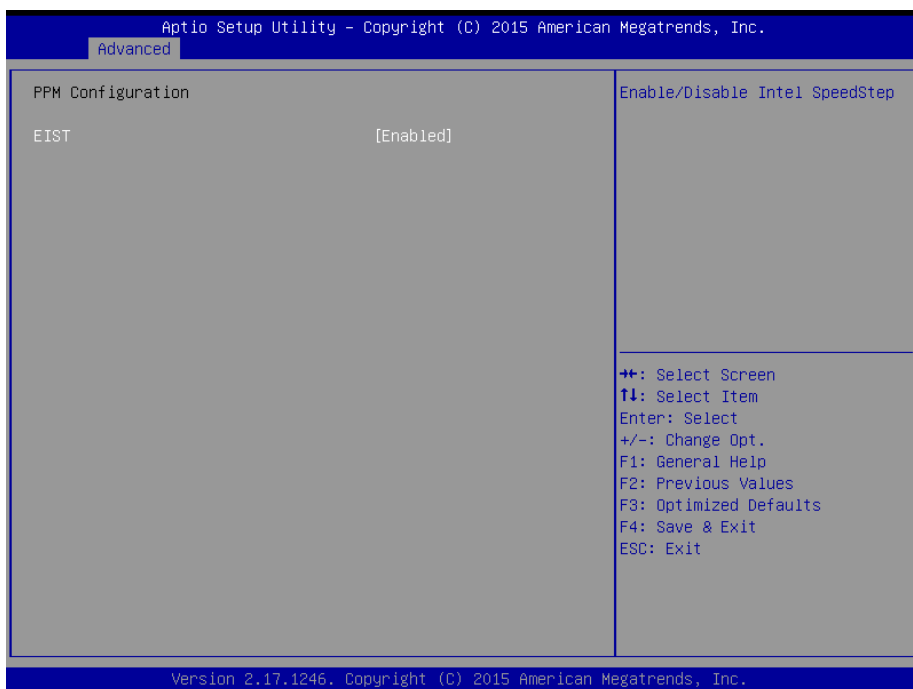

#### PPM Configuration Screen

<b>BIOS Setting</b>	<b>Options</b>	<b>Description/Purpose</b>
EIST	- Disabled - Enabled	Enables/Disables Intel SpeedStep.

## 5.4.7 Advanced – IDE Configuration

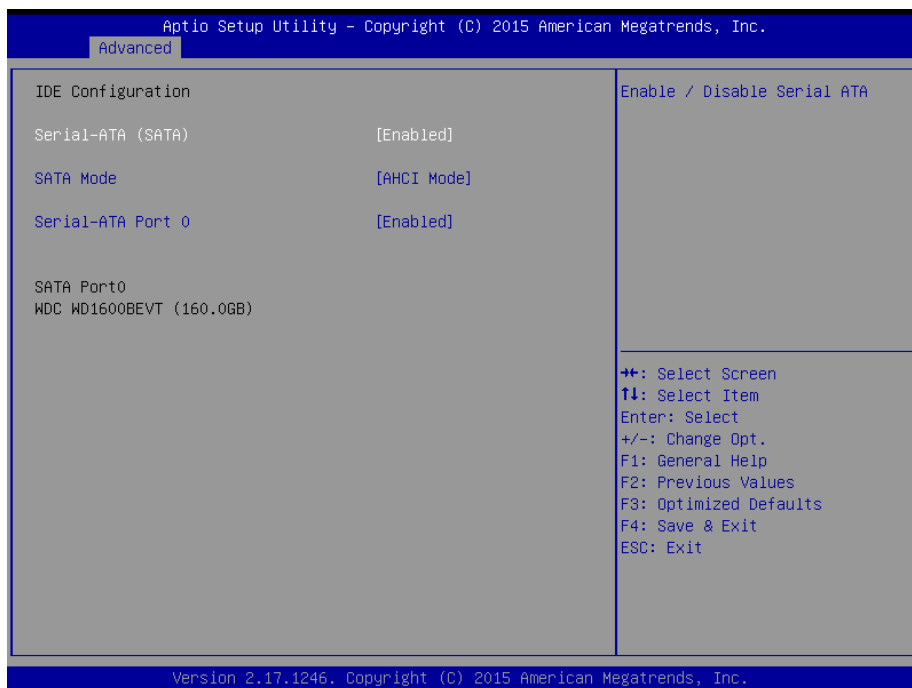

## IDE Configuration Screen

BIOS Setting	Options	Description/Purpose
SATA Controller(s)	- Disabled - Enabled	Enables or disables SATA Device.
SATA Mode	- IDE mode - AHCI mode	Configures SATA as following: <b>IDE:</b> Set SATA operation mode to IDE mode. <b>AHCI:</b> SATA works as AHCI (Advanced Host Controller Interface) mode for getting better performance.
Serial-ATA Port 0	- Disabled - Enabled	Enables or disables SATA port 0 Device.
SATA Port 0	[drive]	Displays the drive installed on this SATA port 0. Shows [Empty] if no drive is installed.

### 5.4.8 Advanced – OS Selection

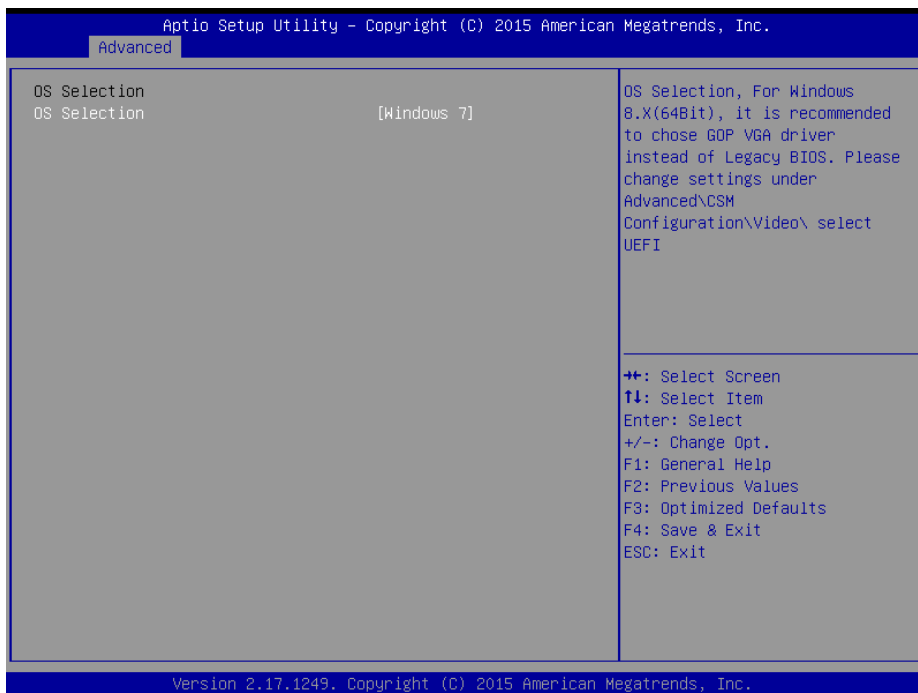

#### OS Selection Configuration Screen

BIOS Setting	Options	Description/Purpose
OS Selection	- Windows 8.x - Windows 7	Select Windows 8.x or Windows 7 Operating System.

**OS Selection:** For Windows 8.x (64Bit), it is recommended to choose GOP VGA driver instead of Legacy BIOS. Please change settings under **Advanced\ CSM\ Configuration\ Video\** select UEFI.

### 5.4.9 Advanced – LPSS & SCC Configuration

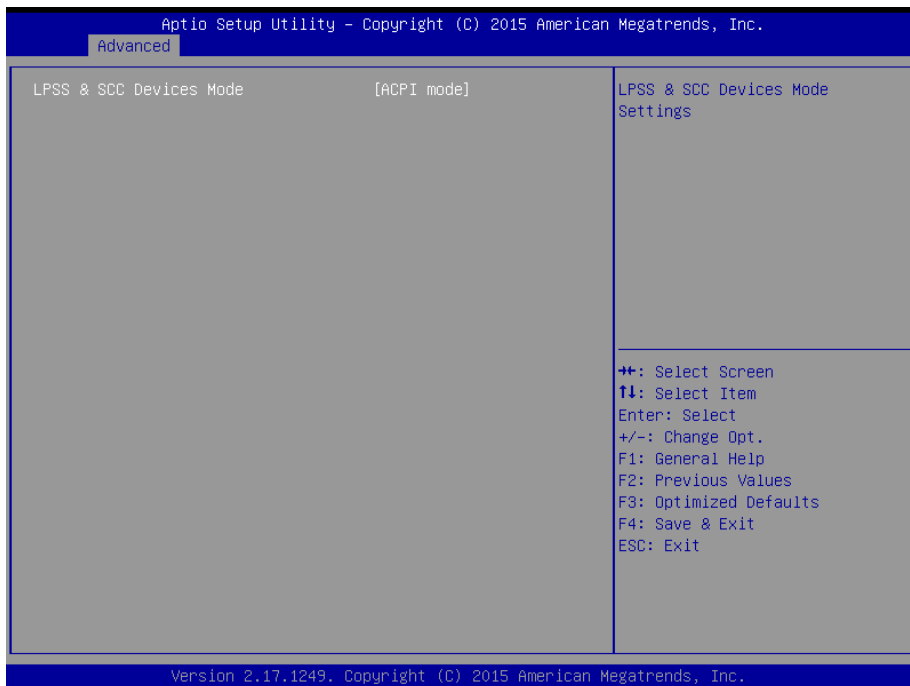

### LPSS & SCC Configuration Screen

BIOS Setting	Options	Description/Purpose
LPSS & SCC Device Mode	- ACPI mode - PCI mode	LPSS & SCC Device mode Settings



## 5.4.10 Advanced – CSM Configuration

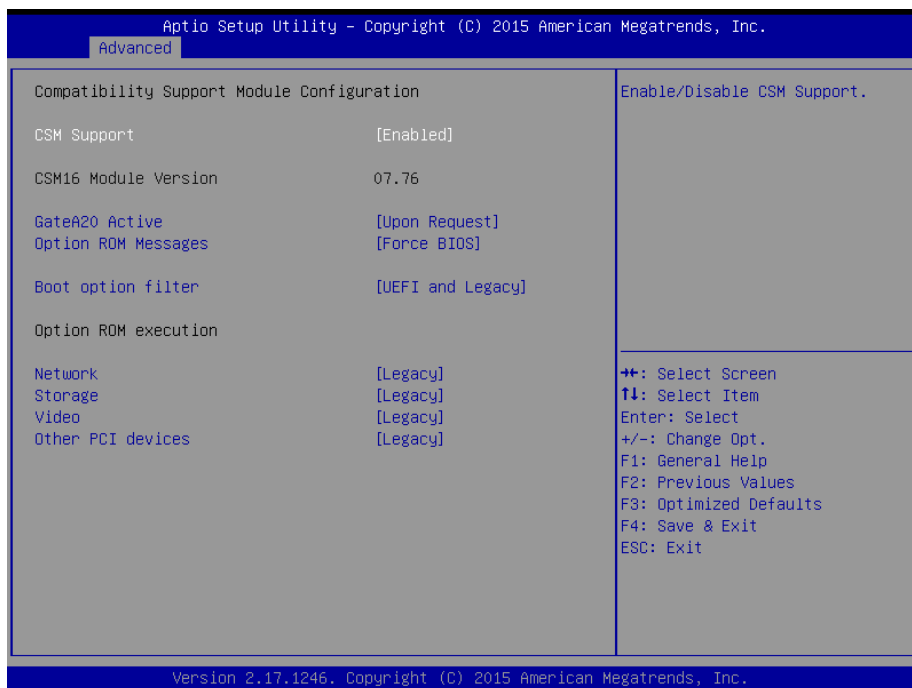

## CSM Configuration Screen

BIOS Setting	Options	Description/Purpose
CSM Support	- Disabled - Enabled	Disables or Enables CSM support.
CSM16 Module Version	No changeable options	Displays the current CSM (Compatibility Support Module) version.
GateA20 Active	- Upon Request - Always	Selects Gate A20 operation mode. <b>UPON REQUEST:</b> GA20 can be disabled using BIOS services. <b>ALWAYS:</b> do not allow disabling GA20; this option is useful when any RT code is executed above 1MB.
Option ROM Messages	- Force BIOS - Keep Current	Sets the display mode for Option ROM messages.
Boot option filter	- UEFI and Legacy - Legacy only - UEFI only	This option controls what kind of devices system can boot.

<b>BIOS Setting</b>	<b>Options</b>	<b>Description/Purpose</b>
Network	- Do not launch - UEFI - Legacy	Controls the execution of UEFI or Legacy PXE
Storage	- Do not launch - UEFI - Legacy	Controls the execution of UEFI or Legacy Storage
Video	- Do not launch - UEFI - Legacy	Controls the execution of UEFI and Legacy Video.
Other PCI devices	- Do not launch - UEFI - Legacy	Determines OpROM execution policy for devices other than Network, Storage, or Video.

## 5.4.11 Advanced – USB Configuration



## USB Configuration Screen

BIOS Setting	Options	Description/Purpose
USB Devices	No changeable options	Displays number of available USB devices.
Legacy USB Support	- Enabled - Disabled - Auto	Enables support for legacy USB.
XHCI Hand-off	- Enabled - Disabled	This is a workaround for OSeS without XHCI hand-off support.
EHCI Hand-off	- Disabled - Enabled	This is a workaround for OSeS without EHCI hand-off support.
USB Mass Storage Driver Support.	- Disabled - Enabled	Enable/Disable USB mass storage driver support.

<b>BIOS Setting</b>	<b>Options</b>	<b>Description/Purpose</b>
USB transfer time-out	1 / 5 / 10 / 20 sec	The time-out value for Control, Bulk, and Interrupt transfers.
Device reset time-out	10 / 20 / 30 / 40 sec	USB mass storage device Start Unit command time-out.
Device power-up delay	- Auto - Manual	Maximum time the device will take before it properly reports itself to the Host Controller. 'Auto' uses default value: for a Root port it is 100 ms, for a Hub port the delay is taken from Hub descriptor.
Device power-up delay in seconds	multiple options ranging from 1 to 40	The delay time range is from 1 to 40 seconds in one second increment.
Mass Storage Devices:	- Auto - Floppy - Force FDD - Hard Disk - CD-ROM	Displays the device name and choose the device emulation type.

## 5.5 Chipset

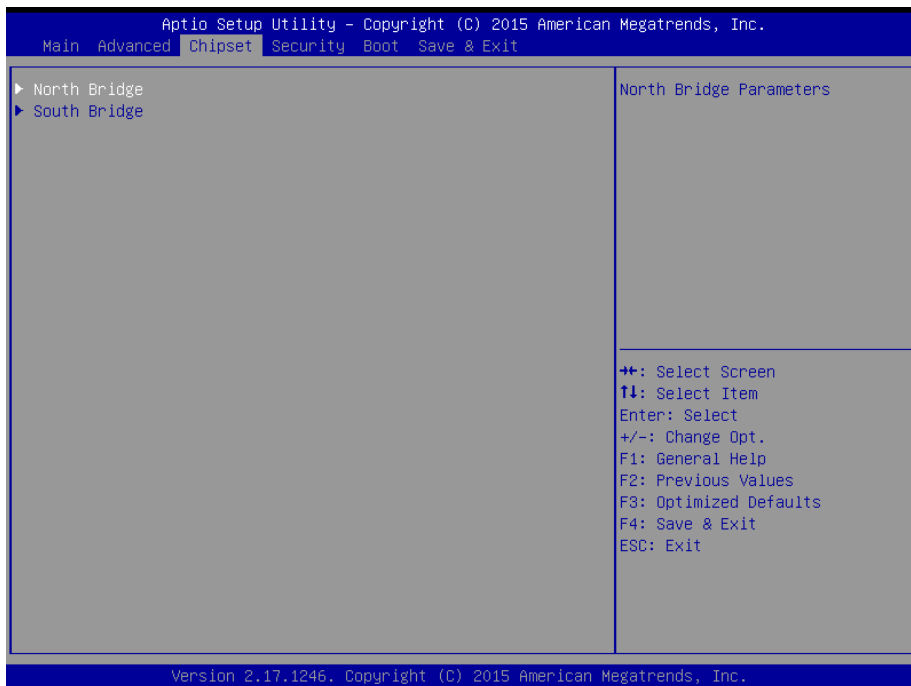

### Chipset Screen

BIOS Setting	Options	Description/Purpose
North Bridge	Sub-menu	Sets Parameter for Panther Point (North Bridge) configuration.
South Bridge	Sub-menu	Sets Parameter for Ivy Bridge (South Bridge) configuration.

## 5.5.1 Chipset – North Bridge

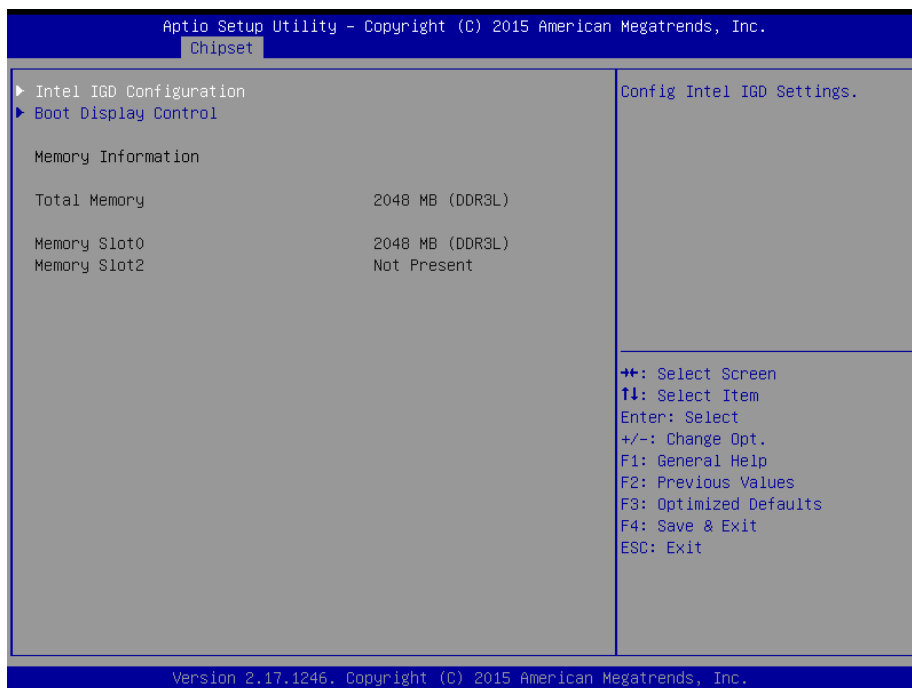

### North Bridge Screen

BIOS Setting	Options	Description/Purpose
Intel IGD Configuration	Sub-menu	Configures Intel IGD Settings.
Boot Display Control	Sub-menu	Boot Display Control.
Memory Information	No changeable options	Displays the DRAM information on platform.
Total Memory	No changeable options	Displays the DRAM size.

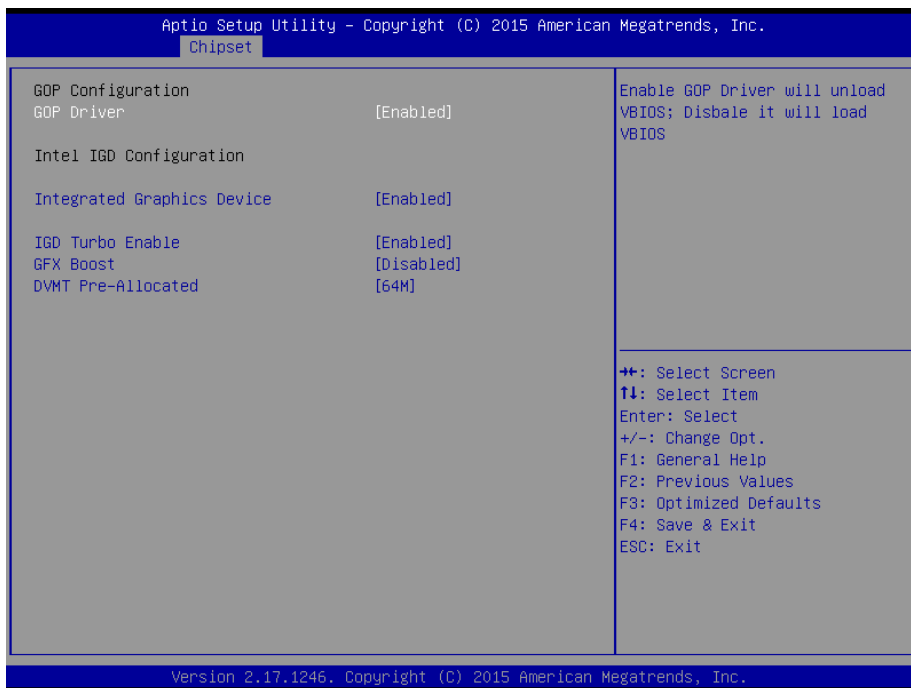

### GOP Configuration Screen

BIOS Setting	Options	Description/Purpose
GOP Driver	- Enabled - Disabled	Enables or disables GOP Driver for UEFI OS
Intel IGD Configuration	No changeable options	Displays the IGD information on platform.
Integrated Graphics Device	- Enabled - Disabled	Enabled: Enable Integrated Graphics Device (IGD) when selected as the Primary Video Adaptor. Disabled: Always disable IGD"
IGD Turbo Enable	- Enabled - Disabled	Enables or disables IGD Turbo
GFX Boost	- Enabled - Disabled	Enables or disables GFX Boost accelerated graphics processing

<b>BIOS Setting</b>	<b>Options</b>	<b>Description/Purpose</b>
DVMT Pre-Allocated	- 64M - 96M - 128M - 256M - 512M	Select DVMT 5.0 Pre-Allocated (Fixed) Graphics Memory size used by the Internal Graphics Device.



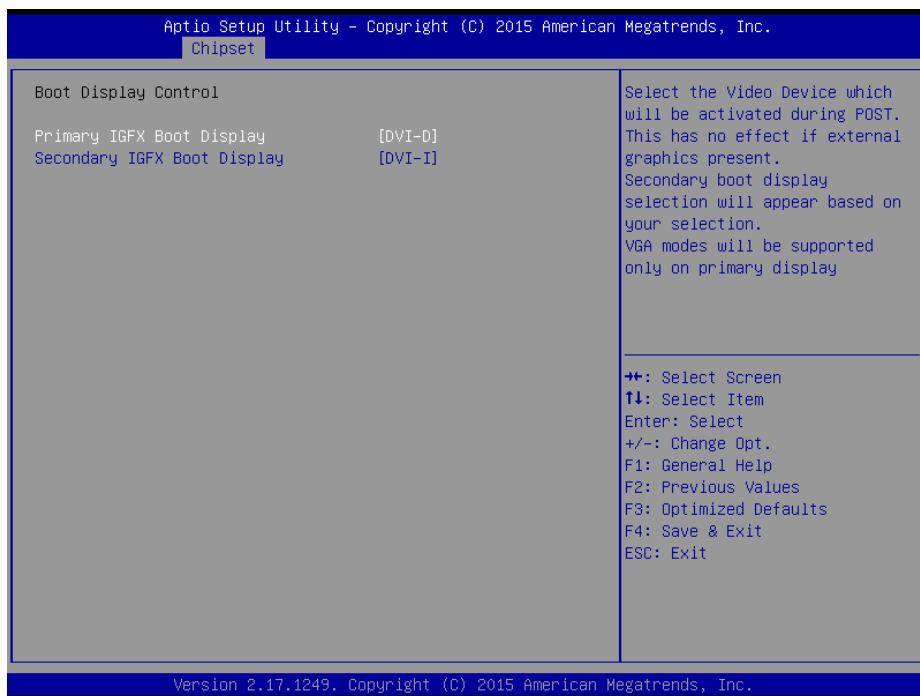

### Boot Display Control Screen

BIOS Setting	Options	Description/Purpose
Primary IGFX Boot Display	- VBIOS Default - DVI-I - DVI-D - LVDS	Selects the Video Device which will be activated during POST.
Secondary IGFX Boot Display	- VBIOS Default - DVI-I - DVI-D - LVDS	Selects the Video Device which will be activated during POST.

## 5.5.2 Chipset – South Bridge

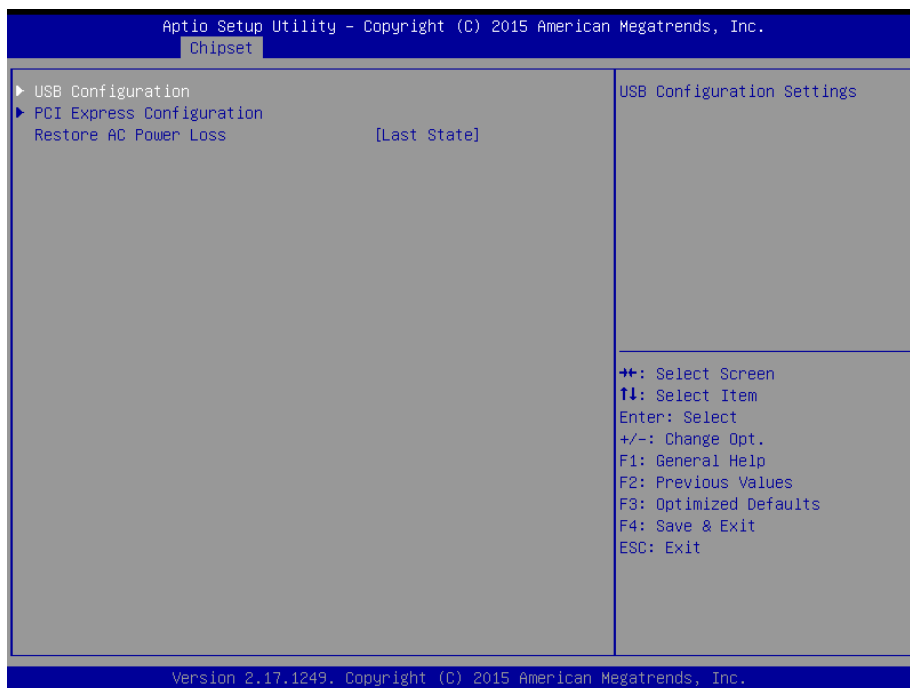

## South Bridge Screen

BIOS Setting	Options	Description/Purpose
USB Configuration	Sub-menu	USB Configuration Settings.
PCI Express Configuration	Sub-menu	PCI Express Configuration Settings.
Restore AC Power Loss	- Power Off - Power On - Last State	Selects AC power state when power is re-applied after a power failure. <b>Power Off</b> keeps the power off till the power button is pressed. <b>Power On</b> makes system power on after restores AC power to the board. <b>Last State</b> brings system back to the last power state before AC remove.

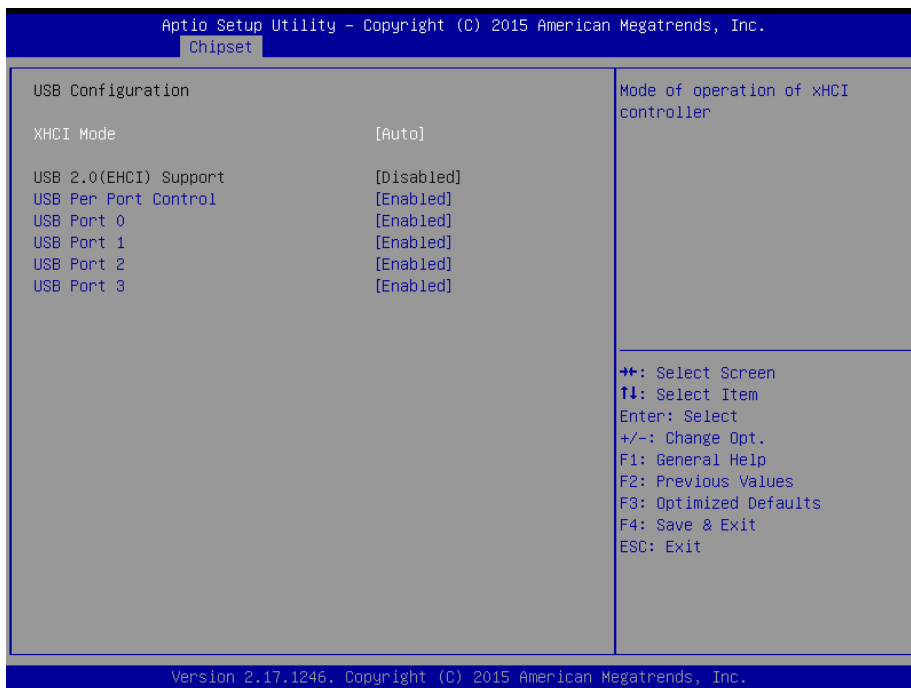

### USB Configuration Screen`

BIOS Setting	Options	Description/Purpose
XHCI Mode	- Disabled - Enabled - Auto - Smart Auto	Selects operation mode of XHCI controller.
USB 2.0(EHCI) Support	- Disabled - Enabled	(XHCI Mode need set disabled.) Enables Enhanced Host Controller Interface 1 for high-speed USB functions (USB 2.0).
USB Per Port Control	- Disabled - Enabled	Enables or Disables per USB port.
USB Port 0	- Disabled - Enabled	Enables or Disables USB port 0.
USB Port 1	- Disabled - Enabled	Enables or Disables USB port 1.
USB Port 2	- Disabled - Enabled	Enables or Disables USB port 2.

<b>BIOS Setting</b>	<b>Options</b>	<b>Description/Purpose</b>
USB Port 3	- Disabled - Enabled	Enabled or Disabled USB port 3.



### **PCI Express Configuration Screen**

<b>BIOS Setting</b>	<b>Options</b>	<b>Description/Purpose</b>
PCI Express Port 0	- Disabled - Enabled	Enables or Disables PCI Express port 0.
Speed	- Auto - Gen1 - Gen2	Selects PCI Express port 0 speed.
PCI Express Port 1	- Disabled - Enabled	Enabled or Disabled PCI Express port 1.

BIOS Setting	Options	Description/Purpose
Speed	- Auto - Gen1 - Gen2	Selects PCI Express port 1speed.

## 5.6 Security

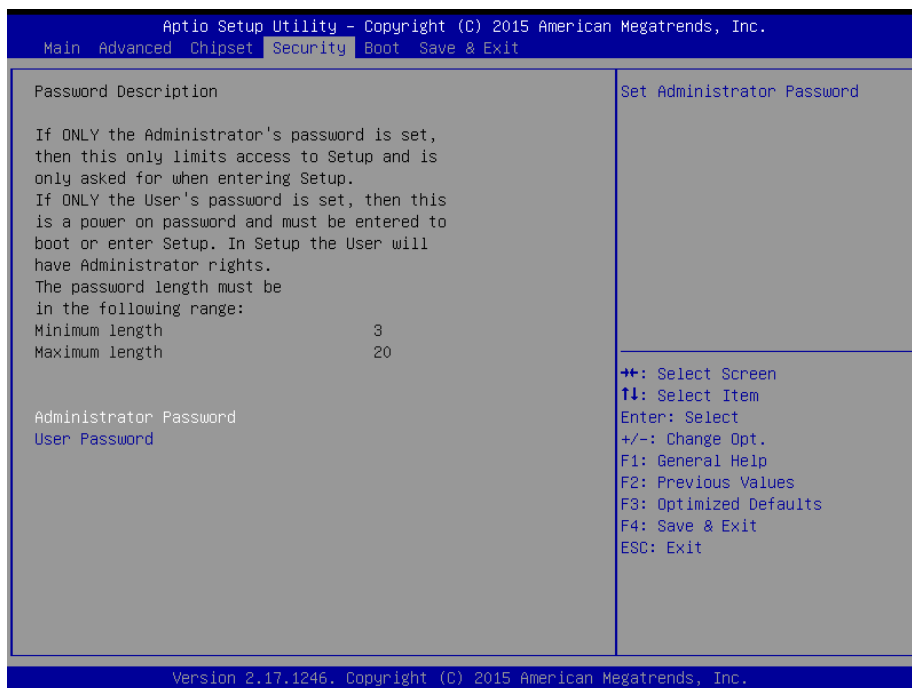

### Security Screen

BIOS Setting	Options	Description/Purpose
Administrator Password	Password can be 3-20 alphanumeric characters.	Specifies the administrator password.
User Password	Password can be 3-20 alphanumeric characters.	Specifies the user password.

## 5.7 Boot

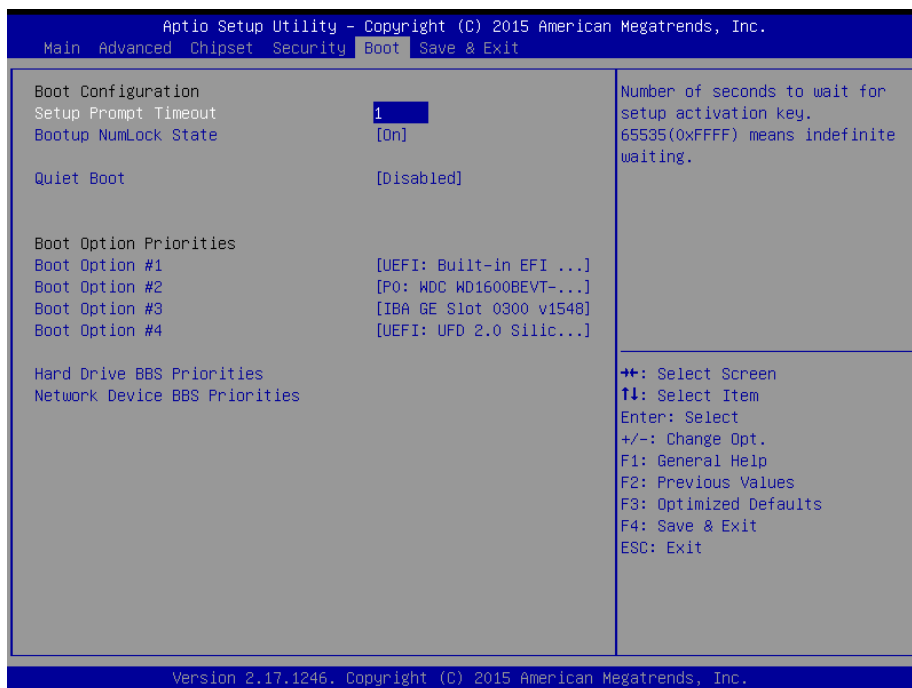

### Boot Screen

BIOS Setting	Options	Description/Purpose
Setup Prompt Timeout	Numeric	Number of seconds to wait for setup activation key.
Bootup NumLock State	- On - Off	Specifies the power-on state of the NumLock Key.
Quiet Boot	- Disabled - Enabled	Enables/Disables Quiet Boot Options.
Boot Option #1~#n	- [Drive(s)] - Disabled	Allows setting boot option listed in Hard Drive BBS Priorities.
Hard Drive BBS Priorities	Sub-Menu	Allows users to select the boot order of available drive(s)
Network Device BBS Priorities	Sub-Menu	Sets the order of the legacy devices in the group.

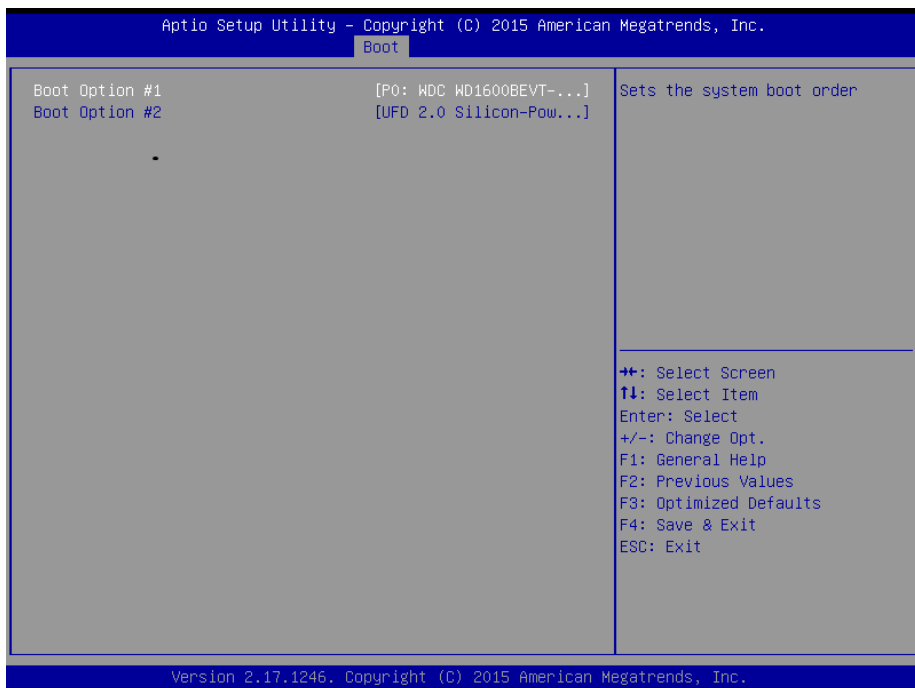

### Hard Drive BBS Priorities Screen

BIOS Setting	Options	Description/Purpose
Boot Option #1 - #n	- [Drive(s)] - Disabled	Changes the boot order of available drive(s).

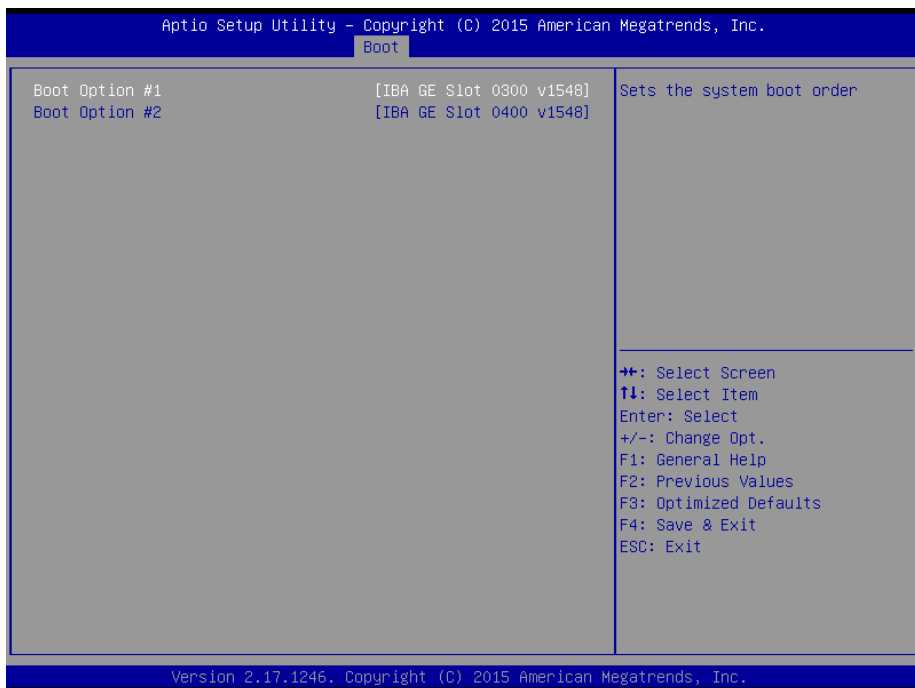

### Network Device BBS Priorities Screen

BIOS Setting	Options	Description/Purpose
Boot Option #1 - #n	- [Drive(s)] - Disabled	Sets the system boot order.



## 5.8 Save & Exit



### Save & Exit Screen

BIOS Setting	Options	Description/Purpose
Save Changes and Exit	No changeable options	Exits and saves the changes in NVRAM.
Discard Changes and Exit	No changeable options	Exits without saving any changes made in BIOS settings.
Save Changes and Reset	No changeable options	Saves the changes in NVRAM and resets.
Discard Changes and Reset	No changeable options	Resets without saving any changes made in BIOS settings.
Restore Defaults	No changeable options	Loads the optimized defaults for BIOS settings.

<b>BIOS Setting</b>	<b>Options</b>	<b>Description/Purpose</b>
Boot Override	- [Drive(s)]	Forces to boot from selected [drive(s)].

# ***SYSTEM ASSEMBLY***

*APPENDIX*

***A***

This appendix contains the exploded diagrams & part numbers of the SE-8124 system.

Section includes:

- Exploded Diagram for Bottom Case
- Exploded Diagram for HDD Support Board
- Exploded Diagram for Front & Rear Case
- Exploded Diagram for Motherboard
- Exploded Diagram for Heatsink

**EXPLODED DIAGRAM FOR BOTTOM CASE**

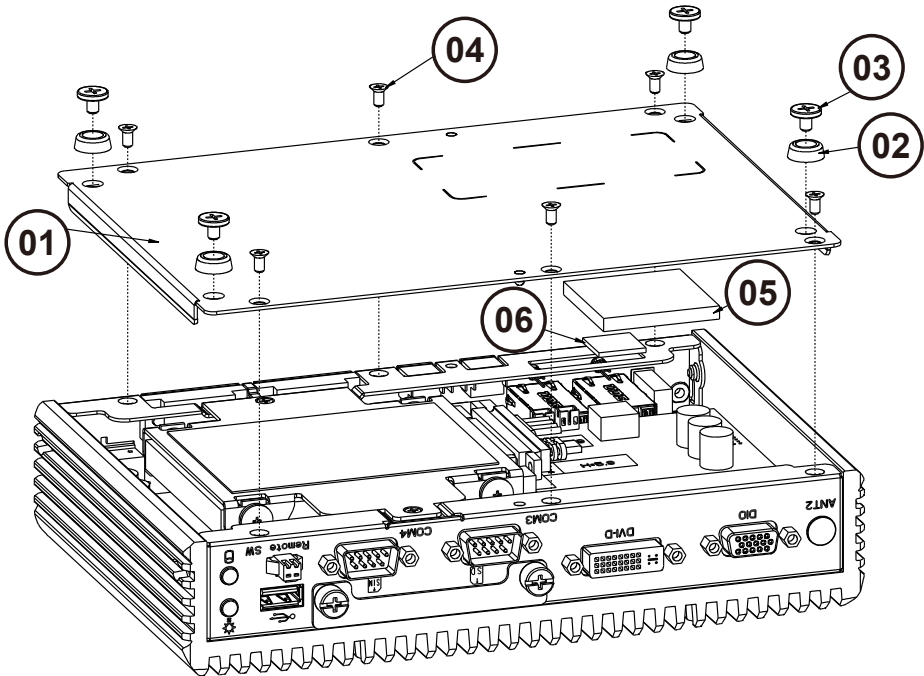

6	THERMAL PAD	81-006-81515002	1
5	HEATSINK-BLOCK	21-002-13535001	1
4	SCREW M3x6mm	22-215-30060011	6
3	SCREW M4x6mm	22-215-40006011	4
2	RUBBER FOOT	90-004-01400000	4
1	BOT-CASE	20-001-03062345	1
No.	Name	P/N No.	Qty

**EXPLODED DIAGRAM FOR HDD SUPPORT BOARD**

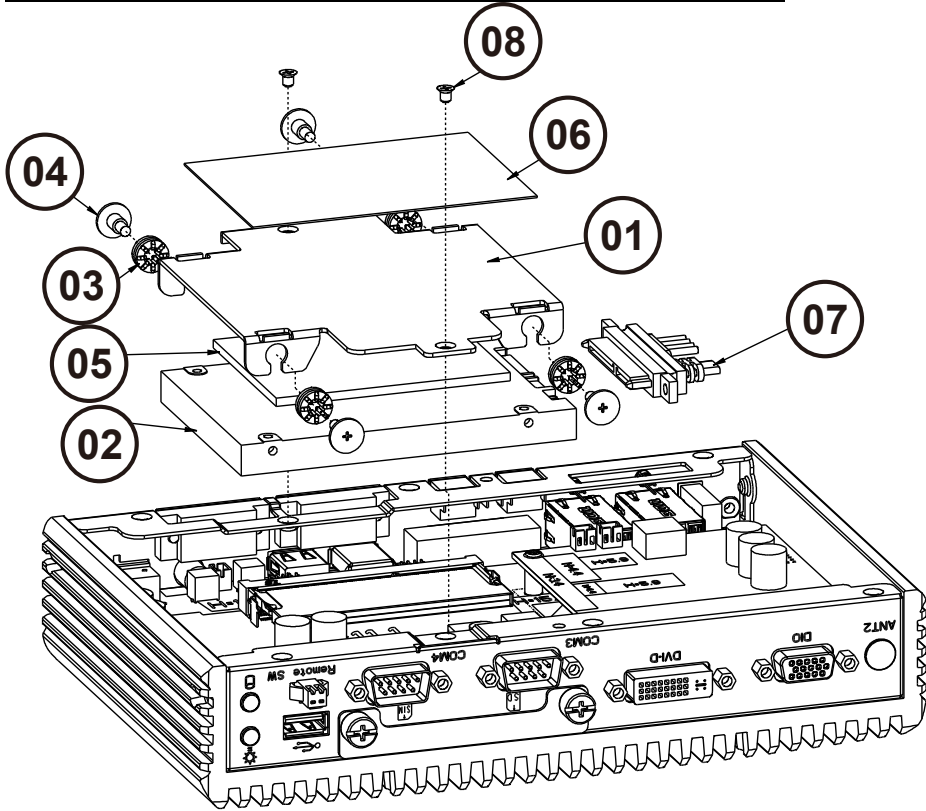

8	SCREW M3x4mm	22-215-30004011	2
7	SATA HDD & POWER CABLE	--	1
6	THERMAL PAD	21-006-88560001	1
5	THERMAL PAD	81-006-87055001	1
4	SCREW M3x4.8mm	82-272-30005013	4
3	RUBBER WASHER	23-680-39580963	4
2	SATA HDD	By order	1
1	HDD-SUPPORT-BOARD	20-002-01001345	1
No.	Name	P/N No.	Qt'y

**EXPLODED DIAGRAM FOR FRONT & BACK CASE**

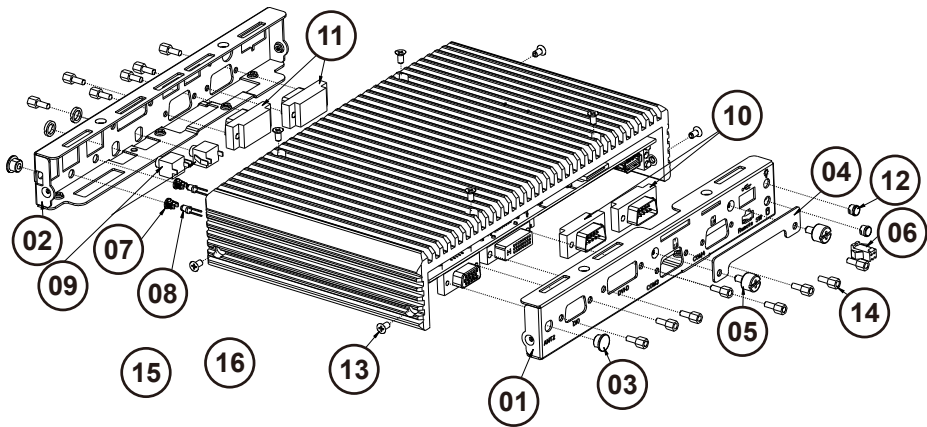

14	HEX CU BOSS	22-692-40048051	14
13	SCREW M3x6mm	22-215-30060011	8
12	LED LIGHT PIPE	30-012-02100000	2
11	COM PORT CABLE	--	2
10	COM PORT CABLE	--	2
9	PHONE JACK CABLE	--	1
8	LED CABLE	--	2
7	LED HOUSING	30-014-04100165	2
6	REMOTE SWITCH CABLE	--	1
5	THEAD SCREW	22-302-06060011	2
4	SD-SIM-COVER	20-004-03061345	1
3	HOLE PLUG	90-067-01100000	2
2	BACK-CASE	20-001-03061345	1
1	FRONT-CASE	20-001-03063345	1
No.	Name	P/N No.	Qt'y

**EXPLODED DIAGRAM FOR MOTHERBOARD**

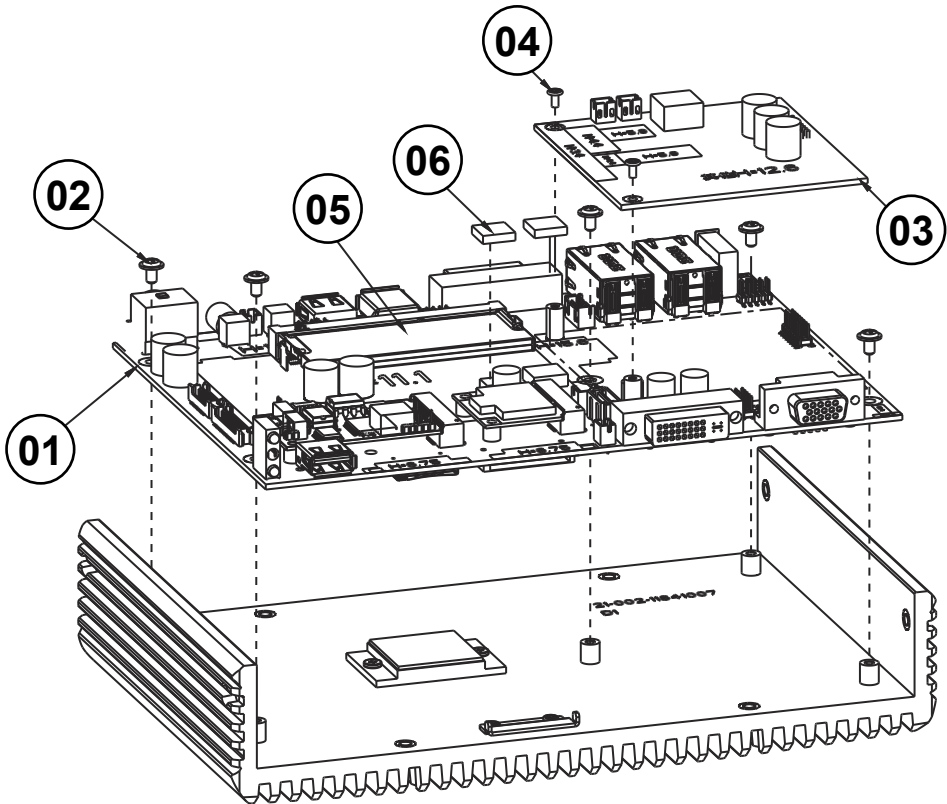

6	SIC HEATSINK	21-002-91010001	2
5	SO-DIMM HEATSINK	21-002-16925001	1
4	SCREW M2x4mm	22-272-20004011	2
3	SR-8124	By order	1
2	SCREW M3x5mm	22-242-30005311	5
1	SB-8124	--	1
No.	Name	P/N No.	Qt'y

**EXPLODED DIAGRAM FOR HEATSINK**

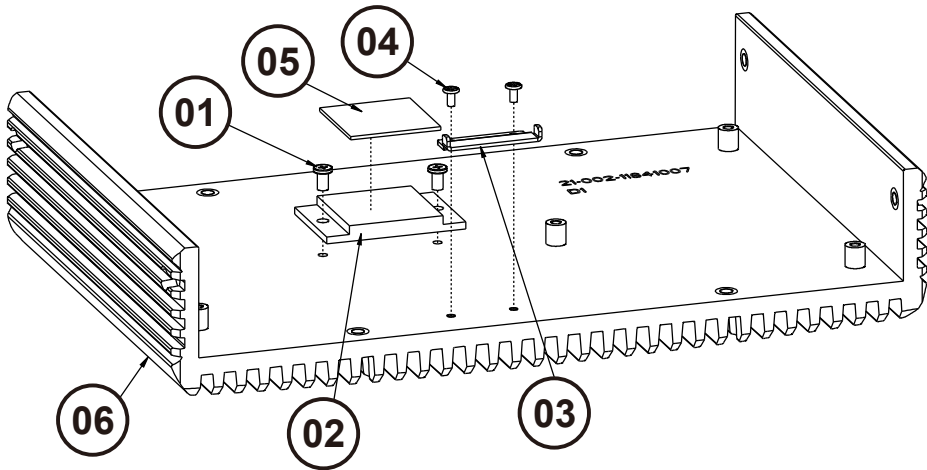

6	HEATSINK	21-002-11841007	1
5	THERMAL PAD	81-006-82626002	1
4	SCREW M2x4mm	22-272-20004011	2
3	SD-COVER-HOLDER	20-029-03001345	1
2	CPU-HEAT-BLOCK	21-002-24027001	1
1	SCREW M3x5mm	22-272-30049015	2
No.	Name	P/N No.	Qt'y



# ***TECHNICAL SUMMARY***

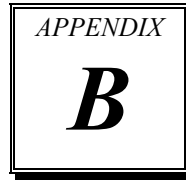

This section introduces you the maps concisely.

Section includes:

- Block Diagram
- Interrupt Map
- I/O Map
- Memory Map
- Watchdog Timer Configuration
- Flash BIOS Update

**BLOCK DIAGRAM**

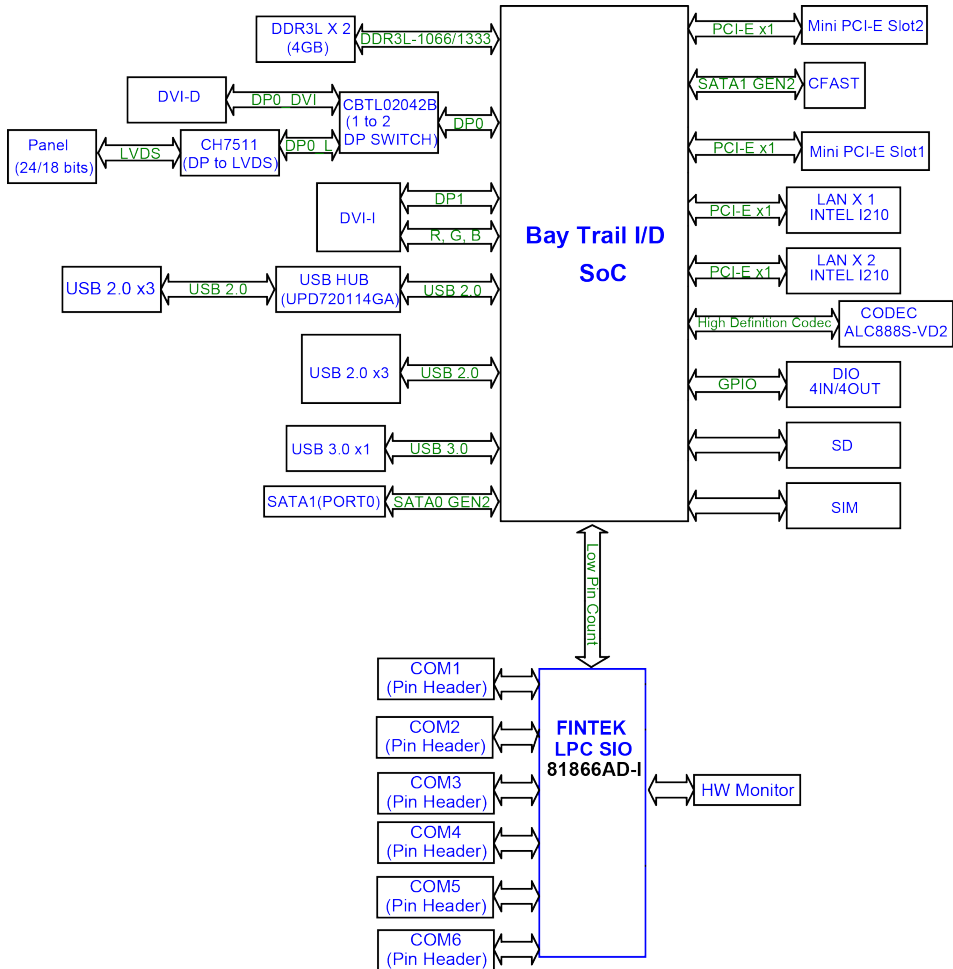

**INTERRUPT MAP**

<b>IRQ MAP</b>	<b>ASSIGNMENT</b>
(ISA) IRQ 0	System timer
(ISA) IRQ 3	Communications Port (COM2)
(ISA) IRQ 4	Communications Port (COM1)
(ISA) IRQ 5	Communications Port (COM5)
(ISA) IRQ 7	Communications Port (COM3)
(ISA) IRQ 8	High precision event timer
(ISA) IRQ10	Communications Port (COM4)
(ISA) IRQ11	Communications Port (COM6)
(ISA) IRQ 81	Microsoft ACPI-Compliant System
(ISA) IRQ 82	Microsoft ACPI-Compliant System
(ISA) IRQ 83	Microsoft ACPI-Compliant System
(ISA) IRQ 84	Microsoft ACPI-Compliant System
(ISA) IRQ 85	Microsoft ACPI-Compliant System
(ISA) IRQ 86	Microsoft ACPI-Compliant System
(ISA) IRQ 87	Microsoft ACPI-Compliant System
(ISA) IRQ 88	Microsoft ACPI-Compliant System
(ISA) IRQ 89	Microsoft ACPI-Compliant System
(ISA) IRQ 90	Microsoft ACPI-Compliant System
(ISA) IRQ 91	Microsoft ACPI-Compliant System
(ISA) IRQ 92	Microsoft ACPI-Compliant System
(ISA) IRQ 93	Microsoft ACPI-Compliant System
(ISA) IRQ 94	Microsoft ACPI-Compliant System
(ISA) IRQ 95	Microsoft ACPI-Compliant System
(ISA) IRQ 96	Microsoft ACPI-Compliant System
(ISA) IRQ 97	Microsoft ACPI-Compliant System
(ISA) IRQ 98	Microsoft ACPI-Compliant System

<b>IRQ MAP</b>	<b>ASSIGNMENT</b>
(ISA) IRQ 99	Microsoft ACPI-Compliant System
(ISA) IRQ 100	Microsoft ACPI-Compliant System
(ISA) IRQ 101	Microsoft ACPI-Compliant System
(ISA) IRQ 102	Microsoft ACPI-Compliant System
(ISA) IRQ 103	Microsoft ACPI-Compliant System
(ISA) IRQ 104	Microsoft ACPI-Compliant System
(ISA) IRQ 105	Microsoft ACPI-Compliant System
(ISA) IRQ 106	Microsoft ACPI-Compliant System
(ISA) IRQ 107	Microsoft ACPI-Compliant System
(ISA) IRQ 108	Microsoft ACPI-Compliant System
(ISA) IRQ 109	Microsoft ACPI-Compliant System
(ISA) IRQ 110	Microsoft ACPI-Compliant System
(ISA) IRQ 111	Microsoft ACPI-Compliant System
(ISA) IRQ 112	Microsoft ACPI-Compliant System
(ISA) IRQ 113	Microsoft ACPI-Compliant System
(ISA) IRQ 114	Microsoft ACPI-Compliant System
(ISA) IRQ 115	Microsoft ACPI-Compliant System
(ISA) IRQ 116	Microsoft ACPI-Compliant System
(ISA) IRQ 117	Microsoft ACPI-Compliant System
(ISA) IRQ 118	Microsoft ACPI-Compliant System
(ISA) IRQ 119	Microsoft ACPI-Compliant System
(ISA) IRQ 120	Microsoft ACPI-Compliant System
(ISA) IRQ 121	Microsoft ACPI-Compliant System
(ISA) IRQ 122	Microsoft ACPI-Compliant System
(ISA) IRQ 123	Microsoft ACPI-Compliant System
(ISA) IRQ 124	Microsoft ACPI-Compliant System
(ISA) IRQ 125	Microsoft ACPI-Compliant System

<b>IRQ MAP</b>	<b>ASSIGNMENT</b>
(ISA) IRQ 126	Microsoft ACPI-Compliant System
(ISA) IRQ 127	Microsoft ACPI-Compliant System
(ISA) IRQ 128	Microsoft ACPI-Compliant System
(ISA) IRQ 129	Microsoft ACPI-Compliant System
(ISA) IRQ 130	Microsoft ACPI-Compliant System
(ISA) IRQ 131	Microsoft ACPI-Compliant System
(ISA) IRQ 132	Microsoft ACPI-Compliant System
(ISA) IRQ 133	Microsoft ACPI-Compliant System
(ISA) IRQ 134	Microsoft ACPI-Compliant System
(ISA) IRQ 135	Microsoft ACPI-Compliant System
(ISA) IRQ 136	Microsoft ACPI-Compliant System
(ISA) IRQ 137	Microsoft ACPI-Compliant System
(ISA) IRQ 138	Microsoft ACPI-Compliant System
(ISA) IRQ 139	Microsoft ACPI-Compliant System
(ISA) IRQ 140	Microsoft ACPI-Compliant System
(ISA) IRQ 141	Microsoft ACPI-Compliant System
(ISA) IRQ 142	Microsoft ACPI-Compliant System
(ISA) IRQ 143	Microsoft ACPI-Compliant System
(ISA) IRQ 144	Microsoft ACPI-Compliant System
(ISA) IRQ 145	Microsoft ACPI-Compliant System
(ISA) IRQ 146	Microsoft ACPI-Compliant System
(ISA) IRQ 147	Microsoft ACPI-Compliant System
(ISA) IRQ 148	Microsoft ACPI-Compliant System
(ISA) IRQ 149	Microsoft ACPI-Compliant System
(ISA) IRQ 150	Microsoft ACPI-Compliant System
(ISA) IRQ 151	Microsoft ACPI-Compliant System
(ISA) IRQ 152	Microsoft ACPI-Compliant System

<b>IRQ MAP</b>	<b>ASSIGNMENT</b>
(ISA) IRQ 153	Microsoft ACPI-Compliant System
(ISA) IRQ 154	Microsoft ACPI-Compliant System
(ISA) IRQ 155	Microsoft ACPI-Compliant System
(ISA) IRQ 156	Microsoft ACPI-Compliant System
(ISA) IRQ 157	Microsoft ACPI-Compliant System
(ISA) IRQ 158	Microsoft ACPI-Compliant System
(ISA) IRQ 159	Microsoft ACPI-Compliant System
(ISA) IRQ 160	Microsoft ACPI-Compliant System
(ISA) IRQ 161	Microsoft ACPI-Compliant System
(ISA) IRQ 162	Microsoft ACPI-Compliant System
(ISA) IRQ 163	Microsoft ACPI-Compliant System
(ISA) IRQ 164	Microsoft ACPI-Compliant System
(ISA) IRQ 165	Microsoft ACPI-Compliant System
(ISA) IRQ 166	Microsoft ACPI-Compliant System
(ISA) IRQ 167	Microsoft ACPI-Compliant System
(ISA) IRQ 168	Microsoft ACPI-Compliant System
(ISA) IRQ 169	Microsoft ACPI-Compliant System
(ISA) IRQ 170	Microsoft ACPI-Compliant System
(ISA) IRQ 171	Microsoft ACPI-Compliant System
(ISA) IRQ 172	Microsoft ACPI-Compliant System
(ISA) IRQ 173	Microsoft ACPI-Compliant System
(ISA) IRQ 174	Microsoft ACPI-Compliant System
(ISA) IRQ 175	Microsoft ACPI-Compliant System
(ISA) IRQ 176	Microsoft ACPI-Compliant System
(ISA) IRQ 177	Microsoft ACPI-Compliant System
(ISA) IRQ 178	Microsoft ACPI-Compliant System
(ISA) IRQ 179	Microsoft ACPI-Compliant System

<b>IRQ MAP</b>	<b>ASSIGNMENT</b>
(ISA) IRQ 180	Microsoft ACPI-Compliant System
(ISA) IRQ 181	Microsoft ACPI-Compliant System
(ISA) IRQ 182	Microsoft ACPI-Compliant System
(ISA) IRQ 183	Microsoft ACPI-Compliant System
(ISA) IRQ 184	Microsoft ACPI-Compliant System
(ISA) IRQ 185	Microsoft ACPI-Compliant System
(ISA) IRQ 186	Microsoft ACPI-Compliant System
(ISA) IRQ 187	Microsoft ACPI-Compliant System
(ISA) IRQ 188	Microsoft ACPI-Compliant System
(ISA) IRQ 189	Microsoft ACPI-Compliant System
(ISA) IRQ 190	Microsoft ACPI-Compliant System
(PCI) IRQ 5	Ethernet Controller
(PCI) IRQ 5	SM Bus Controller
(PCI) IRQ 10	Universal Serial Bus (USB) Controller
(PCI) IRQ 11	Ethernet Controller
(PCI) IRQ 11	Video Controller (VGA Compatible)
(PCI) IRQ 16	PCI standard PCI-to-PCI bridge
(PCI) IRQ 17	PCI standard PCI-to-PCI bridge
(PCI) IRQ 18	PCI standard PCI-to-PCI bridge
(PCI) IRQ 18	SDA Standard Compliant SD Host Controller
(PCI) IRQ 19	PCI standard PCI-to-PCI bridge
(PCI) IRQ 19	Standard AHCI 1.0 Serial ATA Controller
(PCI) IRQ 22	High Definition Audio Controller
(PCI) IRQ 23	Standard Enhanced PCI to USB Host Controller

**Note:** The resource information is gathered by Windows 7 (the IRQ could be assigned differently depending on your OS).

## **I/O MAP**

<b>I/O MAP</b>	<b>ASSIGNMENT</b>
0x00000000-0x0000006F	PCI bus
0x00000020-0x00000021	Programmable interrupt controller
0x00000024-0x00000025	Programmable interrupt controller
0x00000028-0x00000029	Programmable interrupt controller
0x0000002C-0x0000002D	Programmable interrupt controller
0x0000002E-0x0000002F	Motherboard resources
0x00000030-0x00000031	Programmable interrupt controller
0x00000034-0x00000035	Programmable interrupt controller
0x00000038-0x00000039	Programmable interrupt controller
0x0000003C-0x0000003D	Programmable interrupt controller
0x00000040-0x00000043	System timer
0x0000004E-0x0000004F	Motherboard resources
0x00000050-0x00000053	System timer
0x00000061-0x00000061	Motherboard resources
0x00000063-0x00000063	Motherboard resources
0x00000065-0x00000065	Motherboard resources
0x00000067-0x00000067	Motherboard resources
0x00000070-0x00000070	Motherboard resources
0x00000070-0x00000070	System CMOS/real time clock
0x00000078-0x000000CF7	PCI bus
0x00000080-0x0000008F	Motherboard resources
0x00000092-0x00000092	Motherboard resources
0x000000A0-0x000000A1	Programmable interrupt controller
0x000000A4-0x000000A5	Programmable interrupt controller
0x000000A8-0x000000A9	Programmable interrupt controller



I/O MAP	ASSIGNMENT
0x000000AC-0x000000AD	Programmable interrupt controller
0x000000B0-0x000000B1	Programmable interrupt controller
0x000000B2-0x000000B3	Motherboard resources
0x000000B4-0x000000B5	Programmable interrupt controller
0x000000B8-0x000000B9	Programmable interrupt controller
0x000000BC-0x000000BD	Programmable interrupt controller
0x000002E0-0x000002E7	Communications Port (COM6)
0x000002E8-0x000002EF	Communications Port (COM4)
0x000002F0-0x000002F7	Communications Port (COM5)
0x000002F8-0x000002FF	Communications Port (COM2)
0x000003B0-0x000003BB	VgaSave
0x000003C0-0x000003DF	VgaSave
0x000003E8-0x000003EF	Communications Port (COM3)
0x000003F8-0x000003FF	Communications Port (COM1)
0x00000400-0x0000047F	Motherboard resources
0x000004D0-0x000004D1	Programmable interrupt controller
0x00000500-0x000005FE	Motherboard resources
0x00000600-0x0000061F	Motherboard resources
0x00000680-0x0000069F	Motherboard resources
0x00000A00-0x00000A0F	Motherboard resources
0x00000A10-0x00000A1F	Motherboard resources
0x00000A20-0x00000A2F	Motherboard resources
0x00000D00-0x0000FFFF	PCI bus
0x0000D000-0x0000D01F	Ethernet Controller
0x0000D000-0x0000DFFF	PCI standard PCI-to-PCI bridge
0x0000E000-0x0000E01F	Ethernet Controller
0x0000E000-0x0000EFFF	PCI standard PCI-to-PCI bridge

**Appendix B Technical Summary**

---

---

<b>I/O MAP</b>	<b>ASSIGNMENT</b>
0x0000F000-0x0000F01F	SM Bus Controller
0x0000F020-0x0000F03F	Standard AHCI 1.0 Serial ATA Controller
0x0000F040-0x0000F043	Standard AHCI 1.0 Serial ATA Controller
0x0000F050-0x0000F057	Standard AHCI 1.0 Serial ATA Controller
0x0000F060-0x0000F063	Standard AHCI 1.0 Serial ATA Controller
0x0000F070-0x0000F077	Standard AHCI 1.0 Serial ATA Controller
0x0000F080-0x0000F087	Video Controller (VGA Compatible)

## MEMORY MAP

MEMORY	ASSIGNMENT
0x000A0000-0x000BFFFF	PCI Bus
0x000A0000-0x000BFFFF	Vga Save
0x000C0000-0x000DFFFF	PCI Bus
0x000E0000-0x000FFFFFF	PCI Bus
0x80000000-0xD0A1AFFF	PCI Bus
0xC0000000-0xCFFFFFFF	Video Controller (VGA Compatible)
0xD0000000-0xD03FFFFF	Video Controller (VGA Compatible)
0xD0400000-0xD04FFFFF	Intel Device
0xD0500000-0xD05FFFFF	Intel Device
0xD0600000-0xD06FFFFF	PCI standard PCI-to-PCI bridge
0xD0600000-0xD07FFFFF	Ethernet Controller
0xD0700000-0xD0703FFF	Ethernet Controller
0xD0800000-0xD08FFFFF	PCI standard PCI-to-PCI bridge
0xD0800000-0xD09FFFFF	Ethernet Controller
0xD0900000-0xD0903FFF	Universal Serial Bus (USB) Controller
0xD0A00000-0xD0A0FFFF	High Definition Audio Controller
0xD0A10000-0xD0A013FFF	SM Bus Controller
0xD0A14000-0xD0A01401F	Standard Enhanced PCI to USB Host Controller
0xD0A15000-0xD0A153FF	Standard AHCI 1.0 Serial ATA Controller
0xD0A16000-0xD0A167FF	SDA Standard Compliant SD Host Controller
0xD0A17000-0xD0A17FFF	SDA Standard Compliant SD Host Controller
0xD0A18000-0xD0A18FFF	Motherboard resources
0xE0000000-0xEFFFFFFF	High precision event timer
0xFED00000-0xFED003FF	Motherboard resources
0xFED01000-0xFED01FFF	Motherboard resources
0xFED03000-0xFED03FFF	Motherboard resources
0xFED04000-0xFED04FFF	Motherboard resources
0xFED08000-0xFED08FFF	Motherboard resources
0xFED0C000-0xFED0FFFF	Motherboard resources
0xFED1C000-0xFED1CFFF	Motherboard resources

<b>MEMORY</b>	<b>ASSIGNMENT</b>
0xFEE00000-0xFEEFFFFFFF	Motherboard resources
0xFEFE0000-0xFEFFFFFFF	Motherboard resources
0xE0000-0xFFFFF	PCI Express Root Complex

## **WATCHDOG TIMER CONFIGURATION**

The I/O port address of the watchdog timer is 2E (hex) and 2F (hex). 2E (hex) is the address port. 2F (hex) is the data port. User must first assign the address of register by writing address value into address port 2E (hex), then write/read data to/from the assigned register through data port 2F (hex).

### **Configuration Sequence**

To program [F81866](#) configuration registers, the following configuration sequence must be followed:

- (1) Enter the extended function mode
- (2) Configure the configuration registers
- (3) Exit the extended function mode

#### **(1) Enter the extended function mode**

To place the chip into the Extended Function Mode, [two successive writes of 0x87](#) must be applied to Extended Function Enable Registers (EFERs, i.e. 2Eh or 4Eh).

#### **(2) Configure the configuration registers**

The chip selects the Logical Device and activates the desired Logical Devices through Extended Function Index Register (EFIR) and Extended Function Data Register (EFDR). The EFIR is located at the same address as the EFER, and the EFDR is located at address (EFIR+1). First, write the Logical Device Number (i.e. 0x07) to the EFIR and then write the number of the desired Logical Device to the EFDR. If accessing the Chip (Global) Control Registers, this step is not required. Secondly, write the address of the desired configuration register within the Logical Device to the EFIR and then write (or read) the desired configuration register through the EFDR.

#### **(3) Exit the extended function mode**

To exit the Extended Function Mode, [writing 0xAA to the EFER](#) is required. Once the chip exits the Extended Function Mode, it is in the normal running mode and is ready to enter the configuration mode.

## Code example for watch dog timer

Enable watchdog timer and set timeout interval to 30 seconds.

```
;----- Enter to extended function mode -----  
mov    dx,    2eh  
mov    al,    87h  
out    dx,    al  
out    dx,    al  
;----- Select Logical Device 8 of watchdog timer -----  
mov    al,    07h  
out    dx,    al  
inc    dx  
mov    al,    08h  
out    dx,    al  
;----- Set second as counting unit -----  
dec    dx  
mov    al,    0f5h  
out    dx,    al  
inc    dx  
in     al,    dx  
and    al,    not 08h  
out    dx,    al  
;----- Set timeout interval as 30seconds and start counting -----  
dec    dx  
mov    al,    0f6h  
out    dx,    al  
inc    dx  
mov    al,    30  
out    dx,    al  
;----- Exit the extended function mode -----  
dec    dx  
mov    al,    0aah  
out    dx,    al
```

## FLASH BIOS UPDATE

### A. Before System BIOS update

1. Prepare a bootable media (ex. USB storage device) which can boot system to DOS prompt.
2. Download and save the BIOS file (ex. [81240TDA.bin](#)) to the bootable device.
3. Copy AMI flash utility – AFUDOS.exe (v5.06.01) into bootable device.
4. Make sure the target system can first boot to the bootable device.
  - a. Connect the bootable USB device.
  - b. Turn on the computer and press <ESC> or <DEL> key during boot to enter BIOS Setup.
  - c. System will go into the BIOS setup menu.
  - d. Select [Boot] menu.
  - e. Select [Hard Drive BBS Priorities], set the USB bootable device to be the 1<sup>st</sup> boot device.
  - f. Press <F4> key to save configuration and exit the BIOS setup menu.

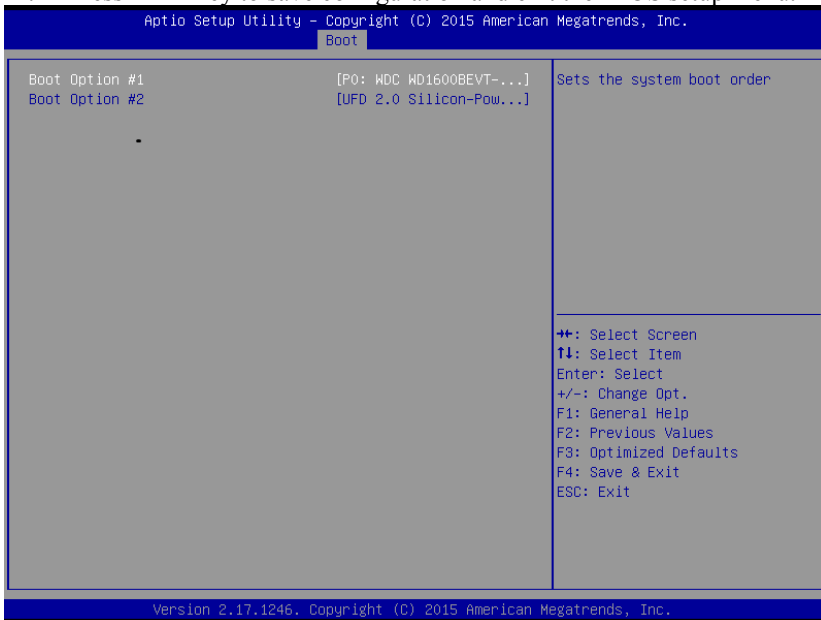

### **B. AFUDOS command for system BIOS update**

AFUDOS.exe is the AMI firmware update utility; the command line is shown as below:

**AFUDOS <ROM File Name> [option1] [option2]....**

User can type “AFUDOS/?” to see all the definition of each control options. The recommended options for BIOS ROM update include following parameters:

- /P**: Program main BIOS image.
- /B**: Program Boot Block.
- /N**: Program NVRAM.
- /X**: Don't check ROM ID.

### **C. BIOS update procedure**

1. Use the bootable USB storage to boot up system into the DOS command prompt.
2. Type "**AFUDOS 8124xxxx.bin /p /b /n /x**" and press enter to start the flash procedure.  
(Note that **xxxx** means the BIOS revision part, ex. 0PD1...)
3. During the update procedure, you will see the BIOS update process status and its percentage. Beware! Do not turn off system power or reset your computer if the whole procedure are not complete yet, or it may crash the BIOS ROM and make system unable to boot up next time.
4. After BIOS update procedures is complete, the messages should be like the figure shown below.

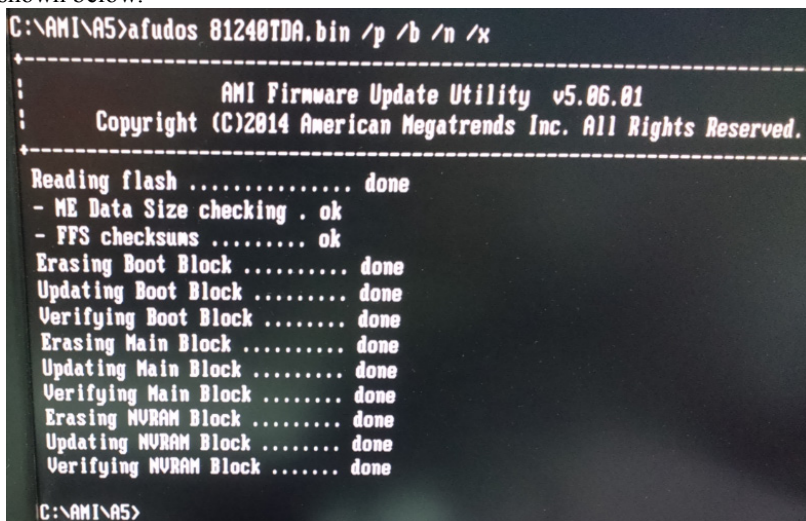

```
C:\AMI\A5>afudos 81240TDA.bin /p /b /n /x
-----
                AMI Firmware Update Utility v5.06.01
                Copyright (C)2014 American Megatrends Inc. All Rights Reserved.
-----
Reading flash ..... done
- ME Data Size checking . ok
- FFS checksums ..... ok
Erasing Boot Block ..... done
Updating Boot Block ..... done
Verifying Boot Block ..... done
Erasing Main Block ..... done
Updating Main Block ..... done
Verifying Main Block ..... done
Erasing NVRAM Block ..... done
Updating NVRAM Block ..... done
Verifying NVRAM Block ..... done
C:\AMI\A5>
```

5. User can restart the system and boot up with new BIOS now.



6. Update is complete after restart.
7. Verify during following boot that the BIOS version displayed at initialization screen has changed.

