

# **USER'S MANUAL**

**SA-5872**

**Intel® 2<sup>nd</sup> Gen. Core™ i7/i5/i3  
& Pentium® & Celeron®  
Book-sized PC**

SA-5872 M1

---

---

***SA-5872 Intel<sup>®</sup> 2<sup>nd</sup> Gen. Core<sup>™</sup>  
i7/i5/i3 & Pentium<sup>®</sup> & Celeron<sup>®</sup>  
Book-sized PC  
With Audio/2LAN/VGA***

**COPYRIGHT NOTICE**

All trademarks and registered trademarks mentioned herein are the property of their respective owners.

This manual is copyrighted in Oct. 2013. You may not reproduce or transmit in any form or by any means, electronic, or mechanical, including photocopying and recording.

**DISCLAIMER**

This operation manual is meant to assist both Embedded Computer manufacturers and end users in installing and setting up the system. The information contained in this document is subject to change without any notice.

**CE NOTICE**

This is a class A product. In a domestic environment this product may cause radio interference in which case the user may be required to take adequate measures.

---

---

---

---

## FCC NOTICE

This equipment has been tested and found to comply with the limits for a Class A digital device, pursuant to part 15 of the FCC Rules. These limits are designed to provide reasonable protection against harmful interference when the equipment is operated in a commercial environment. This equipment generates, uses, and can radiate radio frequency energy and, if not installed and used in accordance with the instruction manual, may cause harmful interference to radio communications. Operation of this equipment in a residential area is likely to cause harmful interference in which case the user will be required to correct the interference at his own expense.

You are cautioned that any change or modifications to the equipment not expressly approve by the party responsible for compliance could void your authority to operate such equipment.

**CAUTION!** Danger of explosion if battery is incorrectly replaced. Replace only with the same or equivalent type recommended by the manufacturer. Dispose of used batteries according to the manufacturer's instructions.

**WARNING!** Some internal parts of the system may have high electrical voltage. And therefore we strongly recommend that qualified engineers open and disassemble the system.

---

---

## TABLE OF CONTENTS

### CHAPTER 1 INTRODUCTION

1-1	About This Manual.....	1-2
1-2	System Illustration.....	1-3
1-3	System Specification.....	1-5
1-4	Safety Precautions.....	1-6

### CHAPTER 2 HARDWARE CONFIGURATION

2-1	Jumper & Connector Quick Reference Table.....	2-2
2-2	Component Locations.....	2-3
2-3	How to Set the Jumpers.....	2-4
2-4	COM Port.....	2-6
2-5	LAN & USB Port.....	2-7
2-6	VGA Port.....	2-9
2-7	Keyboard & Mouse Connector.....	2-9
2-8	COM2 RS-232/422/485 Selection.....	2-10
2-9	COM2 Auto Detect Selection.....	2-11
2-10	USB Connector.....	2-12
2-11	Front Panel Connector & Selection.....	2-13
2-12	Clear CMOS Data Selection.....	2-15
2-13	Fan Connector.....	2-16
2-14	SATA Connector.....	2-17
2-15	Display Port Connector.....	2-18
2-16	Digital Input/Output Connector.....	2-18
2-17	ATX Power Connector.....	2-19
2-18	Audio Connector.....	2-20
2-19	Printer Connector.....	2-21

### CHAPTER 3 SOFTWARE UTILITIES

3-1	Introduction.....	3-2
3-2	Intel® Chipset Software Installation Utility.....	3-3

---

3-3	Intel® Management Engine Components Utility.....	3-4
3-4	VGA Driver Utility.....	3-5
3-5	LAN Driver Utility.....	3-6
3-6	Sound Driver Utility.....	3-7

**CHAPTER 4 BIOS SETUP**

4-1	Introduction.....	4-2
4-2	Entering Setup.....	4-4
4-3	Main.....	4-6
4-4	Advanced.....	4-8
4-5	Chipset.....	4-26
4-6	Boot.....	4-39
4-7	Security.....	4-44
4-8	Save & Exit.....	4-45

**APPENDIX A SYSTEM DIAGRAMS**

Exploded Diagram for the Whole System.....	A-2
--	-----

**APPENDIX B TECHNICAL SUMMARY**

Block Diagram.....	B-2
Interrupt Map.....	B-3
DMA Channels Map.....	B-4
I/O Map.....	B-5
Memory Map.....	B-8
Watchdog Timer Configuration.....	B-9
Flash BIOS Update.....	B-11

# ***INTRODUCTION***

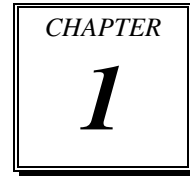

This chapter gives you the information for SA-5872. It also outlines the System specification.

Section includes:

- About This Manual
- System Specifications
- Safety Precautions

**Experienced users can skip to chapter 2 on page 2-1 for Quick Start.**

## **1-1. ABOUT THIS MANUAL**

Thank you for purchasing our SA-5872 Intel® 2<sup>nd</sup> Gen. Core™ i7/i5/i3 & Pentium® & Celeron® Book-sized PC with Audio/2LAN/VGA. SA-5872 provides faster processing speed, greater expandability and can handle more task than before. This manual is designed to assist you how to install and set up the system. It contains four chapters. The user can apply this manual for configuration according to the following chapters:

### ***Chapter 1 Introduction***

This chapter introduces you to the background of this manual, and the specifications for this system. The final page of this chapter will indicate how to avoid damaging this board.

### ***Chapter 2 Hardware Configuration***

This chapter outlines the component locations and their functions. In the end of this chapter, you will learn how to set jumper and how to configure this card to meet your own needs.

### ***Chapter 3 Software Utilities***

This chapter contains helpful information for proper installations of the VGA utility, LAN utility, and Sound utility.

### ***Chapter 4 AMI BIOS Setup***

This chapter indicates you how to set up the BIOS configurations.

### ***Appendix A System Diagrams***

This appendix shows the exploded diagrams and part numbers of SA-5872 components.

### ***Appendix B Technical Summary***

This appendix gives you the information about the Technical maps, Watchdog-timer configuration, and Flash BIOS Update.

## 1-2. SYSTEM ILLUSTRATION

Front View

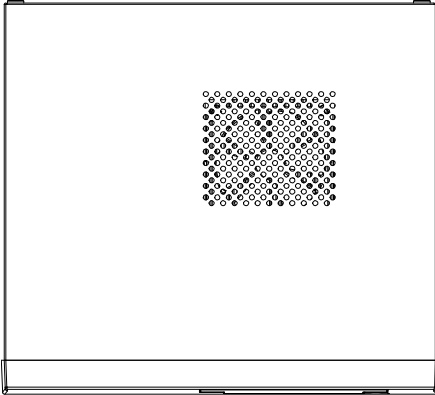

Rear View



Top View

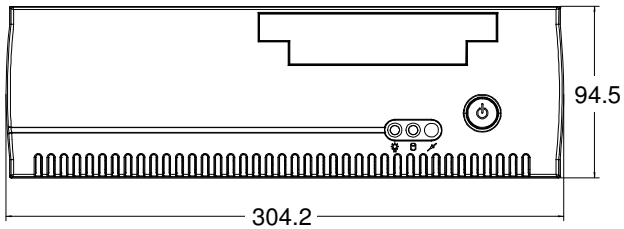

Bottom View

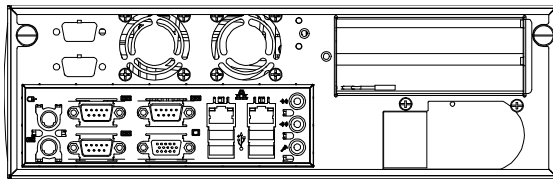

Unit: mm



Side View

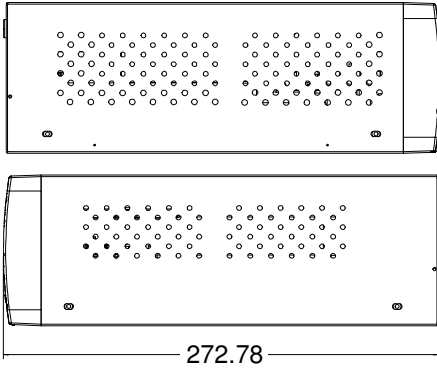

Quarter View

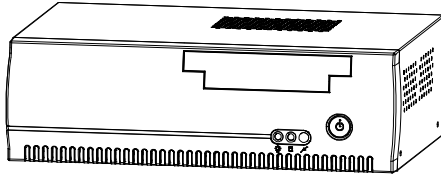

Unit: mm

## 1-3. SYSTEM SPECIFICATION

### System

CPU Support	Intel® 2 <sup>nd</sup> Gen. Core™ i7/i5/i3 & Pentium® & Celeron®
Chipset	Intel® PCH H61
Memory Support	2 x DDR3 1333/1066 MHz DIMM socket (up to 16GB)
Power Supply	ATX 220W
Operating System	Microsoft Windows 7/XP
Drive Bay	2 x 2.5" SATA HDD 1 x Slim DVD-ROM
BIOS	AMI BIOS
System Weight	5 kg (11lb)
Dimension (WxHxD)	300 x 94 x 270 mm (11.8" x 3.7" x 10.6" )
Certificate	FCC/CE

### I/O Ports

USB	4 x USB 2.0
Serial Port	3 x COM port <ul style="list-style-type: none"> <li>▪ <b>COM1/3</b> for RS-232 only</li> <li>▪ <b>COM2</b> for RS-232/422/485</li> </ul>
Keyboard / Mouse	2 x PS/2
LAN	2 x RJ45, 10/100/1000 Mbps, Wake-on-LAN <ul style="list-style-type: none"> <li>▪ <b>LAN1:</b> Intel® 82579V</li> <li>▪ <b>LAN2:</b> Intel® 82583V</li> </ul>
VGA	1 x VGA
Audio	Line-in/Line-out/Mic, Realtek ALC888S High Definition
Expansion Slots	<ul style="list-style-type: none"> <li>▪ 2 x Mini-PCIe</li> <li>▪ 1 x PCIe 16x</li> </ul>

### Environment

Operation Temp.	0 ~ 40°C (32 ~ 104°F)
Storage Temp.	-20 ~ 60°C (-4 ~ 140°F)
Humidity	20 ~ 90%

## **1-4. SAFETY PRECAUTIONS**

Follow the messages below to avoid your systems from damage:

1. Keep your system away from static electricity on all occasions.
2. Prevent electric shock. Don't touch any components of this card when the card is power-on. Always disconnect power when the system is not in use.
3. Disconnect power when you change any hardware devices. For instance, when you connect a jumper or install any cards, a surge of power may damage the electronic components or the whole system.

# ***HARDWARE CONFIGURATION***

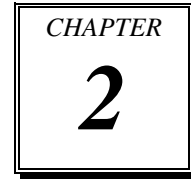

## ***\*\* QUICK START \*\****

Helpful information describes the jumper & connector settings, and component locations.

Sections included:

- Jumper & Connector Quick Reference Table
- Component Locations
- Configuration and Jumper settings
- Connector's Pin Assignments

**2-1. JUMPER & CONNECTOR QUICK REFERENCE TABLE**

<b>JUMPER / CONNECTOR</b>	<b>NAME</b>
COM Port	COM1, COM2, COM3, COM4
LAN & USB Port	LAN1_USB1, LAN2_USB1
VGA Port	VGA1
Keyboard & Mouse Port	KB_MS1
COM2 RS-232/422/485 Selection	JP8
COM2 Auto Detect Selection	JP7
USB Connector	USB45, USB89
Front Panel Connector & Selection	FP1
Clear CMOS Data Selection	JP2
Fan Connector	CPU_FAN1, SYS_FAN1
SATA Connector	SATA1, SATA2, SATA4
Display Port Connector	JDP1
Digital Input/Out Connector	DIO1
ATX Power Connector	ATX_PWR1, ATX_PWR2
Audio Connector	AUDIO1
Printer Connector	LPT1

## 2-2. COMPONENT LOCATIONS

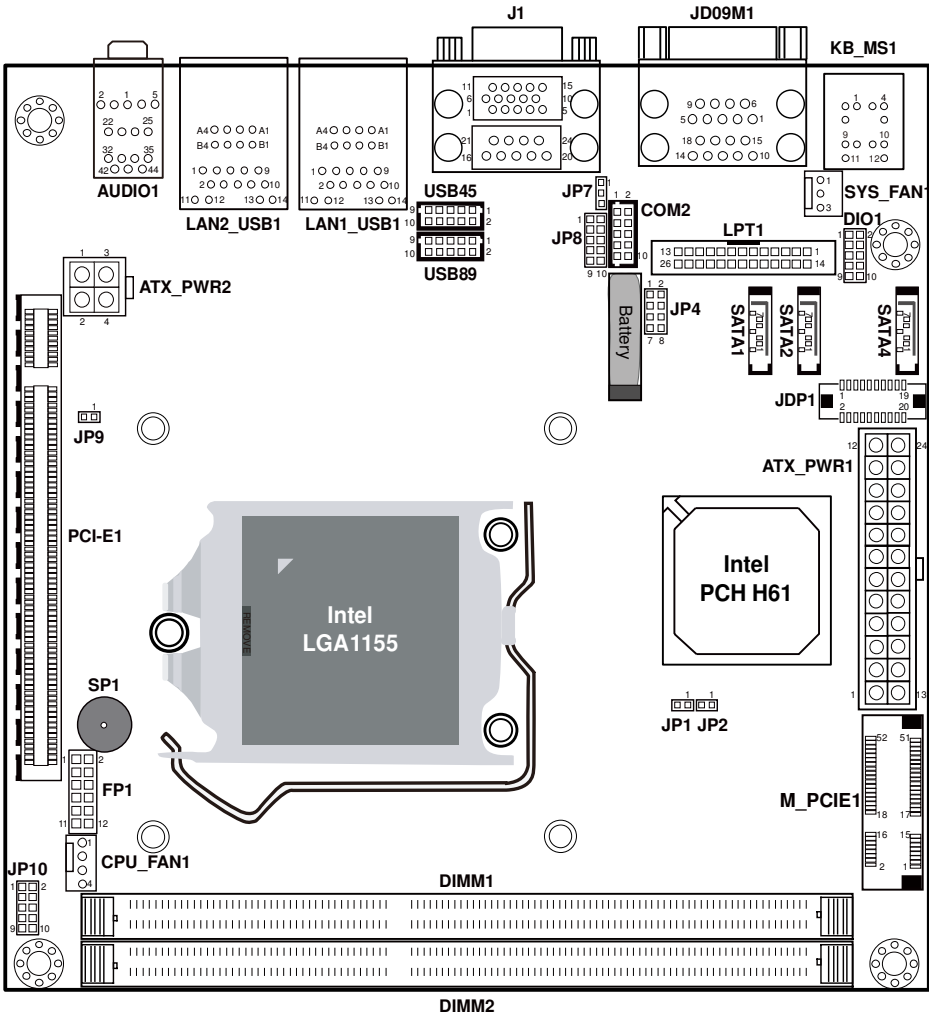

SA-5872 Front Connector, Jumper and Component locations

## 2-3. HOW TO SET THE JUMPERS

You can configure your board by setting jumpers. Jumper is consists of two or three metal pins with a plastic base mounted on the card, and by using a small plastic "cap", Also known as the jumper cap (with a metal contact inside), you are able to connect the pins. So you can set-up your hardware configuration by "open" or "close" pins.

The jumper can be combined into sets that called jumper blocks. When the jumpers are all in the block, you have to put them together to set up the hardware configuration. The figure below shows how this looks like.

### JUMPERS AND CAPS

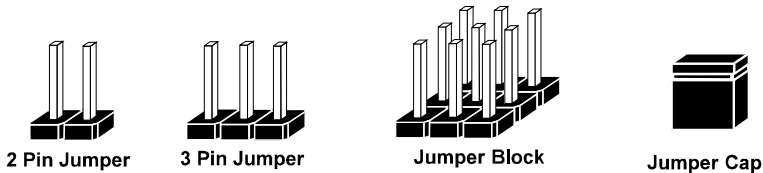

If a jumper has three pins (for examples, labelled PIN1, PIN2, and PIN3), You can connect PIN1 & PIN2 to create one setting by shorting. You can either connect PIN2 & PIN3 to create another setting. The same jumper diagrams are applied all through this manual. The figure below shows what the manual diagrams look and what they represent.

**JUMPER DIAGRAMS**



Jumper Cap  
looks like this



2 pin Jumper  
looks like this

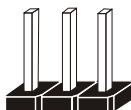

3 pin Jumper  
looks like this

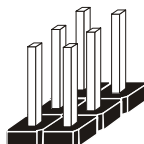
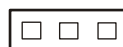

Jumper Block  
looks like this

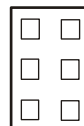

**JUMPER SETTINGS**



2 pin Jumper close(enabled)  
Looks like this



3 pin Jumper  
2-3 pin close(enabled)  
Looks like this



Jumper Block  
1-2 pin close(enabled)  
Looks like this

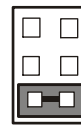



## 2-4. COM PORT

**COM1, COM3, COM4:** COM Ports, fixed as RS-232

The pin assignments are as follows:

PIN	ASSIGNMENT	PIN	ASSIGNMENT
1	COM_DCD#	6	COM_DSR#
2	COM_RX	7	COM_RTS#
3	COM_TX	8	COM_CTS#
4	COM_DTR#	9	COM_RI#
5	GND		

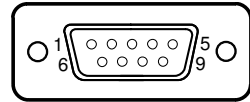

**COM1/  
COM3/  
COM4**

**COM2:** COM2 Port, selectable as RS-232/422/485

The pin assignments are as follows:

PIN	ASSIGNMENT		
	RS-232	RS-422	RS-485
1	COM_DCD#	TX-	485-
2	COM_RX	TX+	485+
3	COM_TX	RX+	X
4	COM_DTR#	RX-	X
5	GND	GND	GND
6	COM_DSR#	X	X
7	COM_RTS#	X	X
8	COM_CTS#	X	X
9	COM_RI#	X	X
10	NC	NC	NC

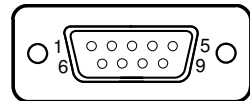

**COM2**

## 2-5. LAN & USB PORT

### LAN1\_USB1: USB & LAN Connector

The pin assignments are as follows:

#### LAN Signal:

PIN	ASSIGNMENT	PIN	ASSIGNMENT
1	LAN1_MDI_0P	5	LAN1_MDI_2P
2	LAN1_MDI_0N	6	LAN1_MDI_2N
3	LAN1_MDI_1P	7	LAN1_MDI_3P
4	LAN1_MDI_1N	8	LAN1_MDI_3N

#### LAN LED Indicator:

Left Side LED

Red Color Blinking	Giga LAN Speed Indicator
Off	No LAN Switch/Hub Connected

Right Side LED

Orange Color on	LAN Message Activer
Off	No LAN Message Active

#### USB Signal:

PIN	ASSIGNMENT	PIN	ASSIGNMENT
A1	VCCUSB1	B1	VCCUSB0
A2	USBP0N	B2	USBP1N
A3	USBP0P	B3	USBP1P
A4	GND	B4	GND

Red Orange

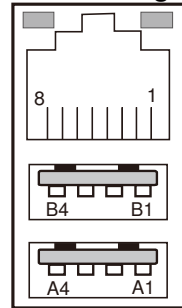

**LAN1\_USB1**

**LAN2\_USB1: USB & LAN Connector**

The pin assignments are as follows:

**LAN Signal:**

PIN	ASSIGNMENT	PIN	ASSIGNMENT
1	LAN2_MDI_0P	5	LAN2_MDI_2P
2	LAN2_MDI_0N	6	LAN2_MDI_2N
3	LAN2_MDI_1P	7	LAN2_MDI_3P
4	LAN2_MDI_1N	8	LAN2_MDI_3N

Red Orange

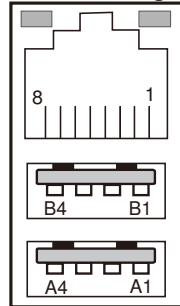

**LAN2\_USB1**

**LAN LED Indicator:**

Left Side LED

Red Color Blinking	Giga LAN Speed Indicator
Off	No LAN Switch/Hub Connected

Right Side LED

Orange Color on	LAN Message Activer
Off	No LAN Message Active

**USB Signal:**

PIN	ASSIGNMENT	PIN	ASSIGNMENT
A1	VCCUSB3	B1	VCCUSB2
A2	USBP2N	B2	USBP3N
A3	USBP2P	B3	USBP3P
A4	GND	B4	GND

## 2-6. VGA PORT

### VGA1: VGA Port

The pin assignments are as follows:

PIN	ASSIGNMENT	PIN	ASSIGNMENT
1	CRTRED	9	CRTVCC_L
2	CRTGREEN	10	GND
3	CRTBLUE	11	NC
4	NC	12	CRTDATA
5	GND	13	HSYNC
6	CRT_ALWAYS_ON	14	VSYNC
7	GND	15	CRTCLK
8	GND		

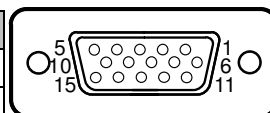

**VGA1**

## 2-7. KEYBOARD & MOUSE CONNECTOR

### KB\_MS1: Keyboard and PS/2 Mouse Connector

The pin assignments are as follows:

PIN	ASSIGNMENT	PIN	ASSIGNMENT
1	KBDATA	7	MSDATA
2	NC	8	NC
3	GND	9	GND
4	VCC5	10	VCC5
5	KBCLK	11	MSCLK
6	NC	12	NC

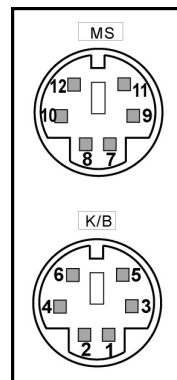

**KB\_MS1**

## 2-8. COM2 RS-232/422/485 SELECTION

**JP8:** COM2 RS-232/422/485 Selection Connector, used to set COM2 function.

The jumper settings are as follows:

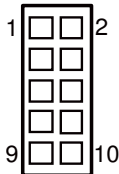
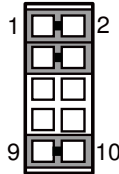
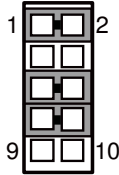

SELECTION	JUMPER SETTINGS	JUMPER ILLUSTRATION
RS-232	All Open	 <p><b>JP8</b></p>
RS-422	1-2, 3-4, 9-10	 <p><b>JP8</b></p>
RS-485	1-2, 5-6, 7-8	 <p><b>JP8</b></p>

**Note:** Manufacturing default is RS-232.

## 2-9. COM2 AUTO DETECT SELECTION

### JP7: COM2 Auto Detect Selection

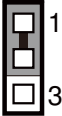
The jumper settings are as follows:

SELECTION	JUMPER SETTINGS	JUMPER ILLUSTRATION
Normal	1-2	 <b>JP7</b>
Auto Gating	2-3	 <b>JP7</b>

**Note:** Manufacturing default is Normal.

## 2-10. USB CONNECTOR

**USB45, USB89:** USB Connectors

The pin assignments are as follows:

### USB45:

PIN	ASSIGNMENT	PIN	ASSIGNMENT
1	USB_45_VCC5	6	USBP5
2	USB_45_VCC5	7	GND
3	USBN4	8	GND
4	USBN5	9	GND
5	USBP4	10	GND



**USB45/  
USB89**

### USB89:

PIN	ASSIGNMENT	PIN	ASSIGNMENT
1	USB_89_VCC5	6	USBP9
2	USB_89_VCC5	7	GND
3	USBN8	8	GND
4	USBN9	9	GND
5	USBP8	10	GND

## 2-11. FRONT PANEL CONNECTOR & SELECTION

### FP1: Front Panel Connector

The pin assignments are as follows:

PIN	ASSIGNMENT	PIN	ASSIGNMENT
1	HDD_LED+	7	RST_BTN
2	PWR_LED+	8	SPEAKER SIGNAL
3	HDD_LED-	9	PWRBTN_SW
4	PWR_LED-	10	SPEAKER SIGNAL
5	GND	11	GND
6	SPK_VCC	12	SPEAKER SIGNAL

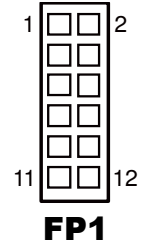

Front Panel selections are as follows:

SELECTION	JUMPER SETTINGS	JUMPER ILLUSTRATION
HDD LED	1-3	<p style="text-align: center;"><b>FP1</b></p>
Power LED	2-4	<p style="text-align: center;"><b>FP1</b></p>



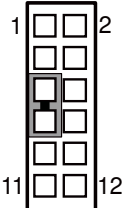
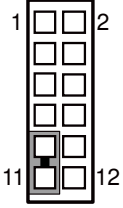
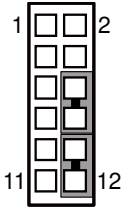

SELECTION	JUMPER SETTINGS	JUMPER ILLUSTRATION
Reset Button	5-7	 <p style="text-align: center;"><b>FP1</b></p>
ATX Power Button	9-11	 <p style="text-align: center;"><b>FP1</b></p>
External Speaker	6-8-10-12	 <p style="text-align: center;"><b>FP1</b></p>

## 2-12. CLEAR CMOS DATA SELECTION

### JP2: Clear CMOS Data Selection

The pin assignments are as follows:

SELECTION	JUMPER SETTING	JUMPER ILLUSTRATION
Normal	Open	 1 <b>JP2</b>
Clear CMOS*	Close	 1 <b>JP2</b>

**Note:** Manufacturing default – Normal

\*To clear CMOS data, user must power-off the computer and set the jumper to “Clear CMOS” as illustrated above. After five to six seconds, set the jumper back to “Normal” and power-on the computer.

## 2-13. FAN CONNECTOR

### CPU\_FAN1: CPU Fan Connector

The pin assignments are as follows:

PIN	ASSIGNMENT
1	GND
2	VCC12
3	CPUFAN_TAC1
4	CPUFAN_CTL1

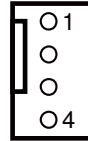

**CPU\_FAN1**

### SYS\_FAN1: System Fan Connector

The pin assignments are as follows:

PIN	ASSIGNMENT
1	GND
2	VCC12
3	LPC1_FANIO2

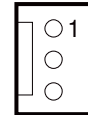

**SYS\_FAN1**

## 2-14. SATA CONNECTOR

**SATA1, SATA2, SATA4:** Serial ATA Connectors

The pin assignments are as follows:

### SATA1:

PIN	ASSIGNMENT	PIN	ASSIGNMENT
1	GND	5	SATA_RXNC0
2	SATA_TXPC0	6	SATA_RXPC0
3	SATA_TXNC0	7	GND
4	GND		



**SATA1/  
SATA2/  
SATA4**

### SATA2:

PIN	ASSIGNMENT	PIN	ASSIGNMENT
1	GND	5	SATA_RXNC1
2	SATA_TXPC1	6	SATA_RXPC1
3	SATA_TXNC1	7	GND
4	GND		

### SATA4:

PIN	ASSIGNMENT	PIN	ASSIGNMENT
1	GND	5	SATA_RXNC4
2	SATA_TXPC4	6	SATA_RXPC4
3	SATA_TXNC4	7	GND
4	GND		

## 2-15. DISPLAY PORT CONNECTOR

### JDP1 Display Port Connector

The pin assignments are as follows:

PIN	ASSIGNMENT	PIN	ASSIGNMENT
1	DP_C_DATA0+	11	GND
2	GND	12	DP_C_DATA3-
3	DP_C_DATA0-	13	DP_C_AUX_ENJ
4	DP_C_DATA1+	14	GND
5	GND	15	DP_C_AUX+
6	DP_C_DATA1-	16	DP_C_HPD
7	DP_C_DATA2+	17	DP_C_AUX-
8	GND	18	DP_VCC3_3
9	DP_C_DATA2-	19	DP_VCC5
10	DP_C_DATA3+	20	DP_VCC3_3



**JDP1**

## 2-16. DIGITAL INPUT/OUTPUT CONNECTOR

### DIO1: Digital I/O Connectors

The pin assignments are as follows:

PIN	ASSIGNMENT	PIN	ASSIGNMENT
1	VCC5	6	DOUT1
2	GND	7	DIN2
3	DIN0	8	DOUT2
4	DOUT0	9	DIN3
5	DIN1	10	DOUT3

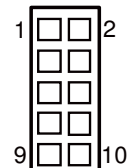

**DIO1**

## 2-17. ATX POWER CONNECTOR

### ATX\_PWR1: ATX Power Connector

The pin assignments are as follows:

PIN	ASSIGNMENT	PIN	ASSIGNMENT
1	+3.3V	13	+3.3V
2	+3.3V	14	-12V
3	GND	15	GND
4	+5V	16	PSON
5	GND	17	GND
6	+5V	18	GND
7	GND	19	GND
8	POK	20	-5V
9	5VSB	21	+5V
10	+12V	22	+5V
11	+12V	23	+5V
12	+3.3V	24	GND

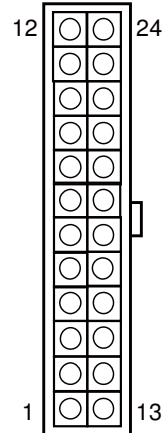

**ATX\_PWR1**

### ATX\_PWR2: ATX Power Connector

The pin assignments are as follows:

PIN	ASSIGNMENT
1	GND
2	GND
3	+12V
4	+12V

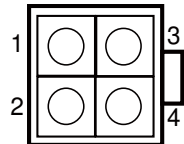

**ATX\_PWR2**

## 2-18. AUDIO CONNECTOR

**AUDIO1:** Audio Connector, including Line-In, Line-Out & MIC, also can support only MIC connector.

The pin assignments are as follows:

### Line-In: (Blue)

PIN	ASSIGNMENT
32	HD_LINE-L
33	GND
34	GND
35	HD_LINE-R

### Line-Out: (Green)

PIN	ASSIGNMENT
22	HD_OUT-L
23	NC
24	NC
25	HD_OUT-R

### MIC-In: (Pink)

PIN	ASSIGNMENT
1	GND
2	HD_MIC1
3	HD_MIC_GND
4	NC
5	HD_MIC_VCC

### SPDIF: (Optional, he same port as Line-In)

PIN	ASSIGNMENT
42	GND
43	VCC_AUD
44	SPDIF OUT

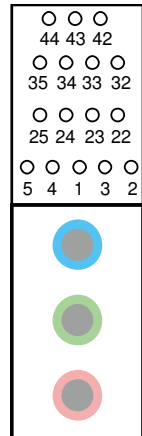

**AUDIO1**

## 2-19. PRINTER CONNECTOR

### LPT1: Printer Connector

To link to a printer, connect both DB25 connector & parallel port with a cable.

The pin assignments are as follows:

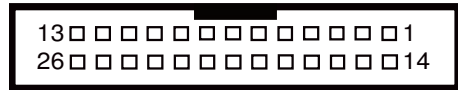

### LPT1

PIN	ASSIGNMENT	PIN	ASSIGNMENT
1	STB	14	AFD#
2	PDR0	15	ERR#
3	PDR1	16	INIT#
4	PDR2	17	SLIN#
5	PDR3	18	GND
6	PDR4	19	GND
7	PDR5	20	GND
8	PDR6	21	GND
9	PDR7	22	GND
10	ACK#	23	GND
11	BUSY	24	GND
12	PE	25	GND
13	SLCT	26	NC



# ***SOFTWARE UTILITIES***

CHAPTER

**3**

This chapter comprises the detailed information of VGA driver, LAN driver, and Sound driver.

Sections included:

- Introduction.
- Intel® Chipset Software Installation Utility
- Intel® Management Engine Components Utility
- VGA Driver Utility
- LAN Driver Utility
- Sound Driver Utility

### 3-1. INTRODUCTION

Enclosed with our SA-5872 package are our driver utilities, which come in a format of CD ROM or floppy disk. Refer to the following table for driver locations:

<b>FILENAME</b> <b>(Assume that CD ROM drive is D:)</b>	<b>PURPOSE</b>
D:\Driver\UTILITY	Intel® Chipset Device Software Installation Utility
D:\Driver\ME	For Intel® Management Engine Interface
D:\Driver\VGA	Intel® HD Graphics Media Accelerator for VGA driver installation
D:\Driver\LAN	Intel® 82579 & 82583 for LAN driver installation
D:\Driver\SOUND	Realtek ALC888S HD audio driver installation

**Note:** Be sure to install the Utility right after the OS fully installed.

## **3-2. INTEL® CHIPSET SOFTWARE INSTALLATION UTILITY**

### **3-2-1. Introduction**

The Intel® Chipset Device Software installs Windows \*.INF files to the target system, and this package contains the drivers for all the interfaces such as USB, SATA, I2C, SPI of the Intel® Platform Controller Hub EG20T with information about a piece of hardware on the system. These files outline to the operating system how to configure the Intel® chipset components in order to ensure that the following features function properly:

- DMA Support
- GPIO Support
- I<sup>2</sup>C Support
- Packet HUB Support
- Serial Peripheral Interface (SPI) Support
- PCIe Support
- IDE/ATA33/ATA66/ATA100 Storage Support
- SATA Storage Support
- USB Support

### **3-2-2. Installation of Utility for Windows XP/7**

The Utility Pack is to be installed only for Windows XP/7 series (32 bit), and it should be installed right after the OS installation. Please follow the steps below:

1. Insert the driver disk into a CD ROM device.
2. Under Windows system, go to the directory where the Utility driver is located.
3. Run the application with administrative privileges.

## **3-3. INTEL® MANAGEMENT ENGINE COMPONENTS UTILITY**

### **3-3-1. Introduction**

The Intel® ME software components that need to be installed depend on the system's specific hardware and firmware features. The installer, compatible with Windows XP/7 (32 bit), detects the system's capabilities and installs the relevant drivers and applications.

### **3-3-2. Installation Instructions for Windows XP/7**

1. Insert the driver disk into a CD ROM device.
2. Under Windows system, go to the directory where the driver is located.
3. Run the application with administrative privileges.

## 3-4. VGA DRIVER UTILITY

### 3-4-1. Introduction

The VGA interface embedded with our SA-5872 can support a wide range of display. You can display CRT, LVDS simultaneously with the same mode.

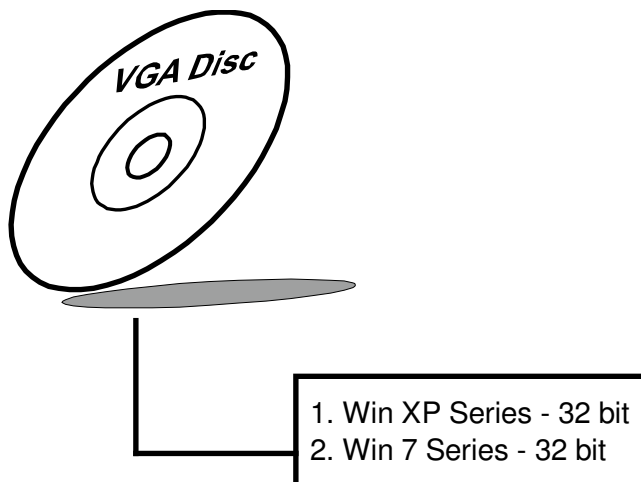

### 3-4-2. Installation of VGA Driver

To install the VGA Driver, simply follow the following steps:

1. Insert the driver disk into a CD ROM device.
2. Under Windows system, go to the directory where the VGA driver is located.
3. Run the application with administrative privileges..

## 3-5. LAN DRIVER UTILITY

### 3-5-1. Introduction

SA-5872 is enhanced with LAN function that can support various network adapters. Installation programs for LAN drivers are listed as follows:

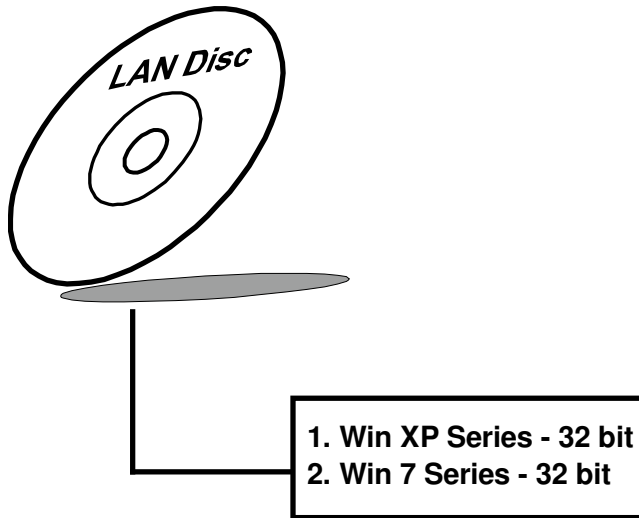

For more details on Installation procedure, please refer to Readme.txt file found on LAN Driver Utility.

## 3-6. SOUND DRIVER UTILITY

### 3-6-1. Introduction

The Realtek sound function enhanced in this system is fully compatible with Windows XP/7. Below, you will find the content of the Sound driver:

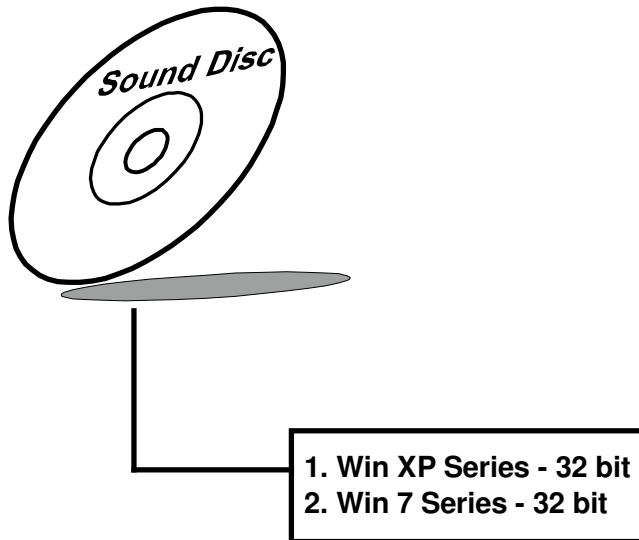

### 3-6-2. Installation of Sound Driver

1. Insert the driver disk into a CD ROM device.
2. Under Windows system, go to the directory where the Sound driver is located.
3. Run the application with administrative privileges..
4. Follow the instructions on the screen to complete the installation.
5. Once the installation is completed, shut down the system and restart in order for the changes to take effect.

# ***BIOS SETUP***

*CHAPTER*

***4***

This chapter shows how to set up the AMI BIOS.

Section includes:

- Introduction
- Entering Setup
- Main
- Advanced
- Chipset
- Boot
- Security
- Save & Exit



## 4-1. INTRODUCTION

The system SA-5872 uses an AMI Aptio BIOS that is stored in the Serial Peripheral Interface Flash Memory (SPI Flash) and can be updated. The SPI Flash contains the BIOS setup menu, Power-on Self-test (POST), the PCI auto-configuration utility, LAN EEPROM information, and Plug and Play support.

Aptio is AMI's BIOS firmware based on the UEFI (Unified Extensible Firmware Interface) specifications and the Intel Platform Innovation Framework for EFI. The UEFI specification defines an interface between an operating system and platform firmware. The interface consists of data tables that contain platform-related information, boot service calls, and runtime service calls that are available to the operating system and its loader. These provide standard environment for booting an operating system and running pre-boot applications.

Following illustration shows Extensible Firmware Interface's position in the software stack.

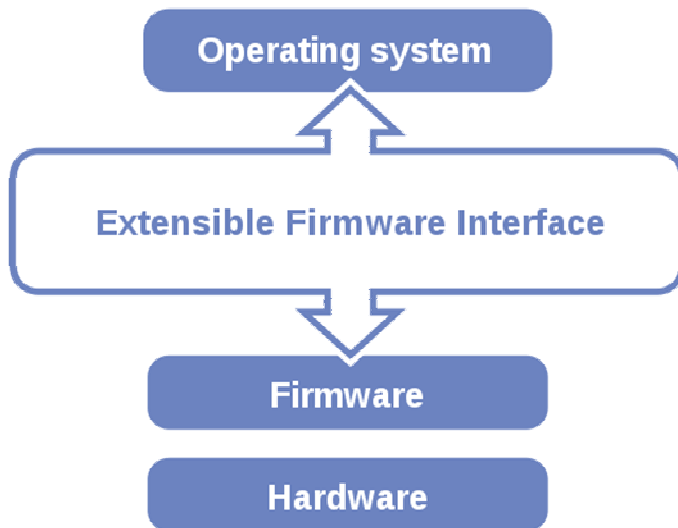

EFI BIOS provides an user interface allow users the ability to modify hardware configuration, e.g. change system date and time, enable or disable a system component, decide bootable device priorities, setup personal password, etc., which is convenient for modifications and customization of the computer system and allows technicians another method for finding solutions if hardware has any problems.

The BIOS setup menu can be used to view and change the BIOS settings for the computer. The BIOS setup menu is accessible by pressing the <Del> or <F2> key on keyboard during the POST stage, right before the operating system is loading. All the settings are described in chapter to be followed.

## **4-2. ENTERING SETUP**

When the system is powered on, the BIOS will enter the Power-on Self-test (POST) routines and the following message will appear on the lower screen:



POST screen

As long as this message is present on the screen you may press the <ESC> or <Del> key (the one that shares the decimal point at the bottom of the number keypad) to access the setup menu. In a moment, the main menu of the Aptio Setup Utility will appear on the screen:

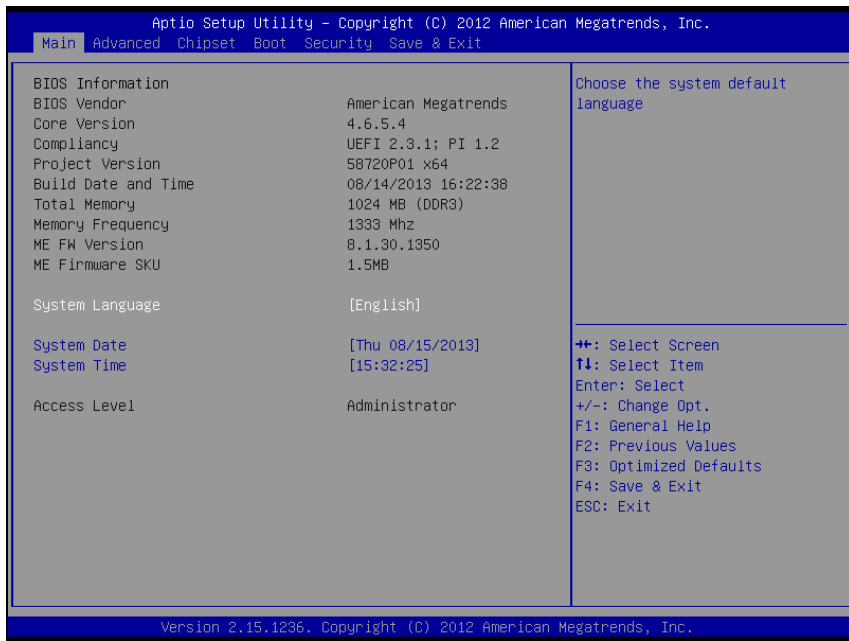

**BIOS setup program initial screen**

You may move the cursor by up/down keys to highlight the individual menu items. As you highlight each item, a brief description of the highlighted selection will appear at the bottom of the screen.

### 4-3. MAIN

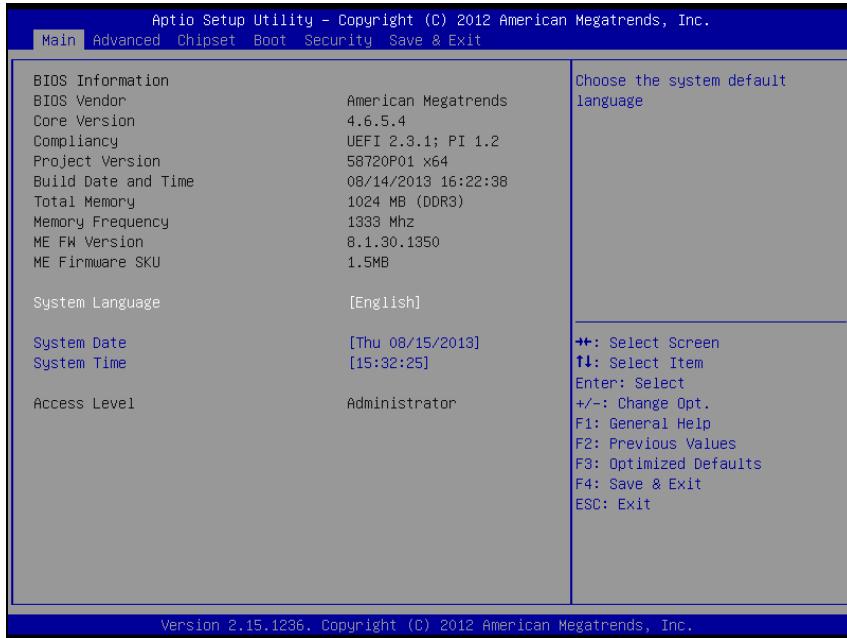

Main Screen

BIOS Setting	Options	Description/Purpose
BIOS Vendor	No changeable options	Displays the BIOS vendor.
Core Version	No changeable options	Displays the current BIOS core version.
Project Version	No changeable options	Displays the version of the BIOS currently installed on the platform.
Build Date	No changeable options	Displays the date of current BIOS version.
Total Memory	No changeable options	Displays the current memory installed amount and type.
Memory Frequency	No changeable options	Displays the current memory frequency
ME FW Version	No changeable options	Displays the ME firmware version

<b>BIOS Setting</b>	<b>Options</b>	<b>Description/Purpose</b>
ME Firmware SKU	No changeable options	Displays the ME firmware SKU
System Date	Month, day, year	Specifies the current date.
System Time	Hour, minute, second	Specifies the current time.

## 4-4. ADVANCED

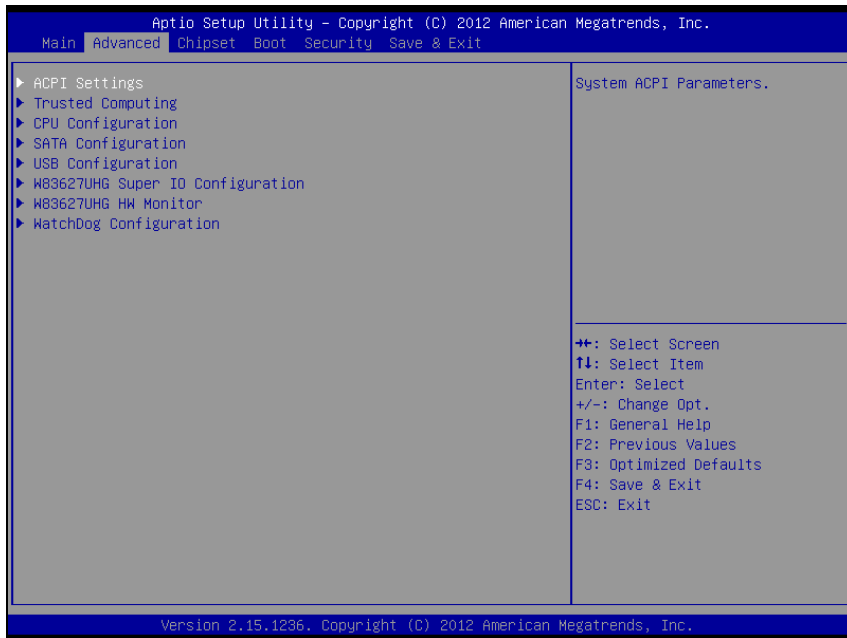

Advanced screen

BIOS Setting	Options	Description/Purpose
ACPI Settings	Enter	System ACPI Parameters
Trusted Computing	Enter	Trusted Computing Settings
CPU Configuration	Enter	CPU Configuration Parameters
SATA Configuration	Enter	SATA Configuration
USB Configuration	Enter	USB Configuration Parameters
W83627UHG Super IO Configuration	Enter	System Super IO Chip Parameters.
W83627UHG HW Monitor	Enter	Monitor hardware status.
WatchDog Configuration	Enter	Watchdog Configuration Settings

### 4-4-1. Advanced – APCI Settings

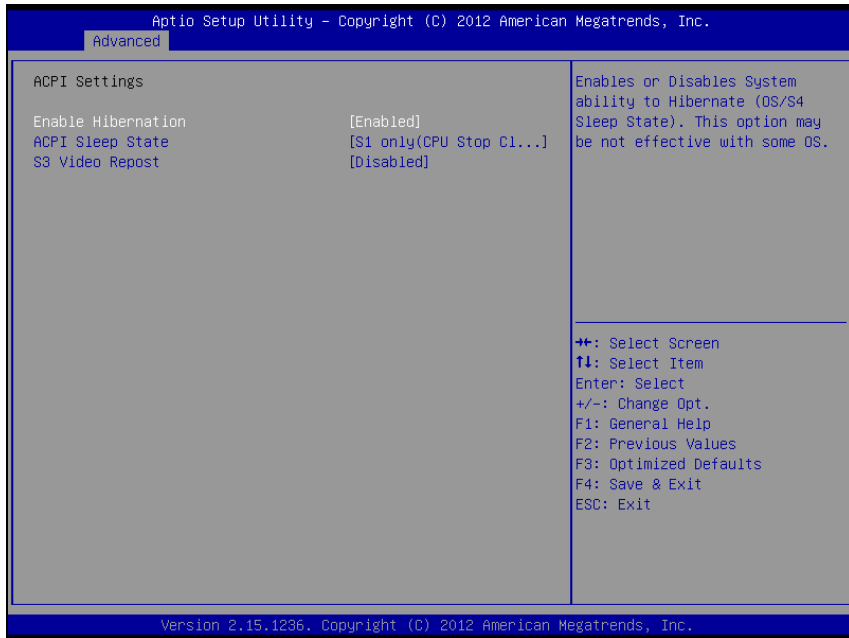

APCI Settings screen

BIOS Setting	Options	Description/Purpose
Enable Hibernation	-Disabled -Enabled	Enables or Disables System ability to Hibernate (OS/S4 Sleep State). This may not be effective with some OS.
ACPI Sleep State	-Suspend Disabled -S1 (CPU Stop Clock) -S3 (Suspend to RAM)	Specifies the ACPI sleep state. <ul style="list-style-type: none"> <li>▪ <b>Disabled</b> disables ACPI sleep feature.</li> <li>▪ <b>S1</b> mode allows the CPU stop executing instructions.</li> <li>▪ <b>S3</b> allows the platform to enter Sleep mode (also known as Standby or Suspend to RAM).</li> </ul>
S3 Video Report	-Disabled -Enabled	Enable or Disable S3 Video Report.



4-4-2. Advanced – Trusted Computing

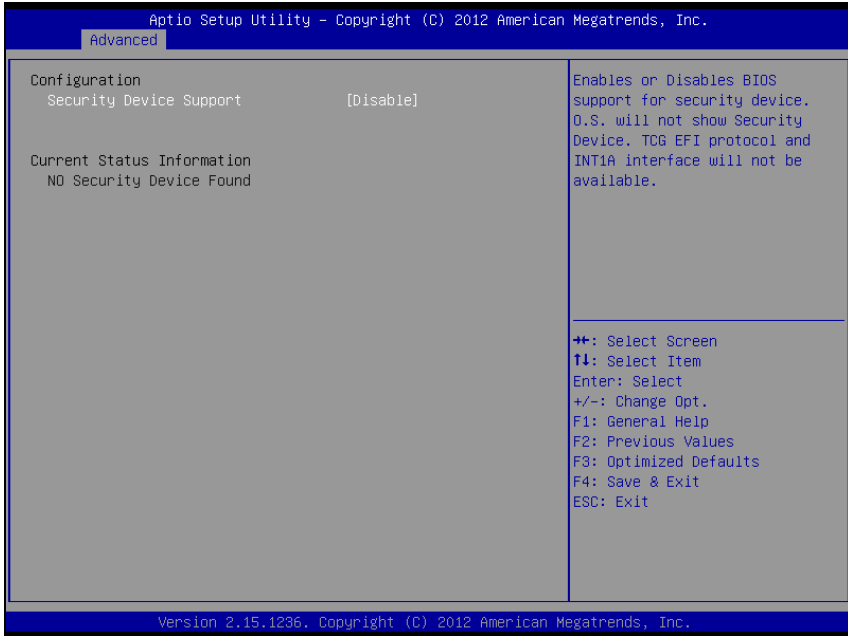

Trusted Computing screen

BIOS Setting	Options	Description/Purpose
Security Device Support	-Disabled -Enabled	Enables or Disables BIOS support for security device. O.S. will not show Security Device. TCG EFI protocol and INT1A interface will not be available.

## 4-4-3. Advanced - CPU Configuration

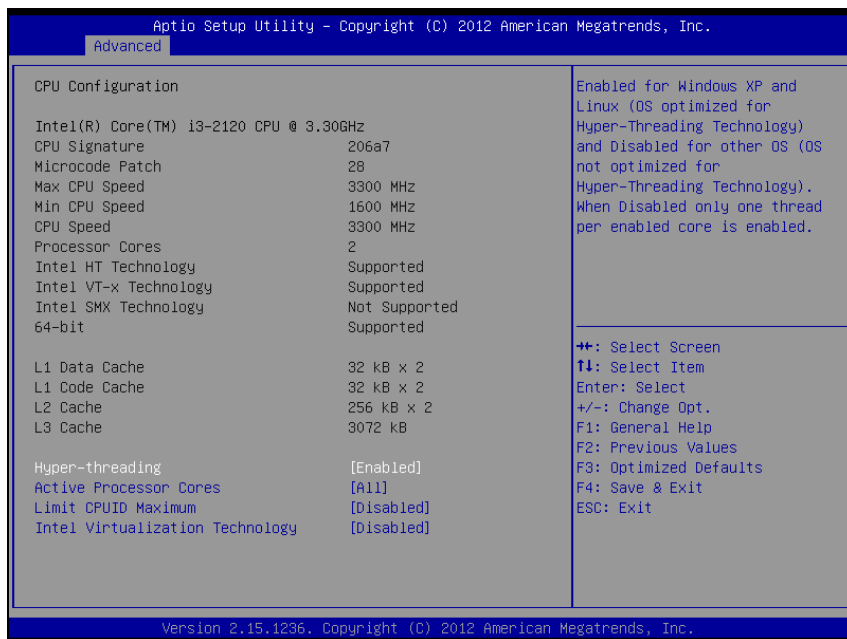

CPU Configuration screen

BIOS Setting	Options	Description/Purpose
Hyper-threading	-Disabled -Enabled	When disabled, only one thread per active core will operate.
Active Processor Cores	-All -1	Indicates the number of cores to enable in processor.
Limit CPUID Maximum	-Disabled -Enabled	Disabled for Windows XP
Intel Virtualization Technology	-Disabled -Enabled	Enables or disables Intel Virtualization Technology (VT-x). Takes affect only after power cycling.

4-4-4. Advanced – SATA Configuration

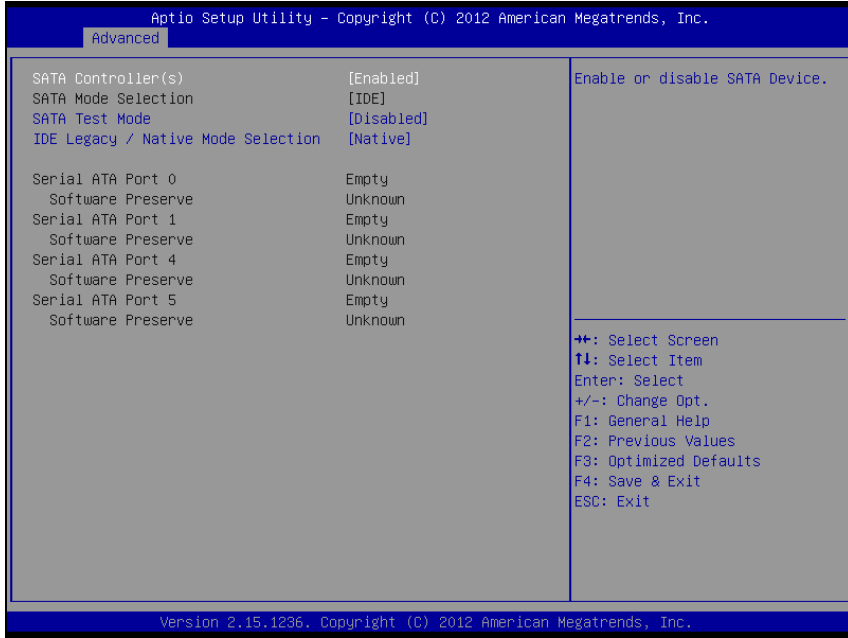

SATA Configuration screen

BIOS Setting	Options	Description/Purpose
SATA Controller(s)	-Disable -Enhanced	Enable or disable SATA Device.
SATA Mode Selection	IDE	SATA Mode Selection
SATA Test Mode	-Disabled -Enabled	Enabled or disable Test Mode
IDE Legacy / Native Mode Selection	-Native -Legacy	IDE Legacy/Native Mode Selection
Serial ATA Port x	[drive]	Displays the SATA device type string
Software Preserve	[drive]	Displays “Support” or “Unknown”

### 4-4-5. Advanced – USB Configuration

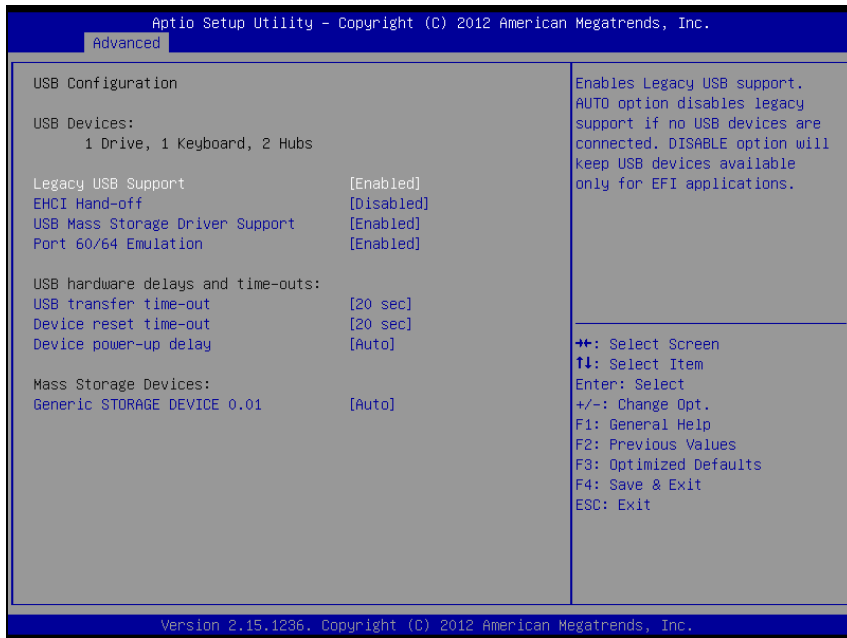

USB Configuration screen

BIOS Setting	Options	Description/Purpose
USB Devices	No changeable options	Displays number of available USB devices.
Legacy USB Support	-Auto -Disabled -Enabled	Enables support for legacy USB.
EHCI Hand-off	-Disabled -Enabled	When enabled it allows BIOS support control of the EHCI controller and the OS handoff synchronization capability.
USB Mass Storage Driver Support	-Disabled -Enabled	Enable/Disable USB Mass Storage Driver Support

<b>BIOS Setting</b>	<b>Options</b>	<b>Description/Purpose</b>
Port 60/64 Emulation	-Disabled -Enabled	Enables I/O port 60h/64h emulation support. This should be enabled for the complete USB keyboard legacy support for non-USB aware OS.
USB transfer time-oujt	-1 sec -5 sec -10 sec -20 sec	Specifies the value for USB transfer time-out.
Device Reset timeout	-10 sec -20 sec -30 sec -40 sec	Specifies the value for device reset timeout.
Device power-up delay	-Auto -Manual	Maximum time the device will take before it properly reports itself to the Host Controller, 'Auto' uses default value: for a Root port it is 100ms, ofr a Hub port the delay is taken from Hub descriptor.
Device power-up delay in seconds	1-40	Delay range is 1~40 seconds, in one second increments.

4-4-6. Advanced – W83627UHG Super IO Configuration

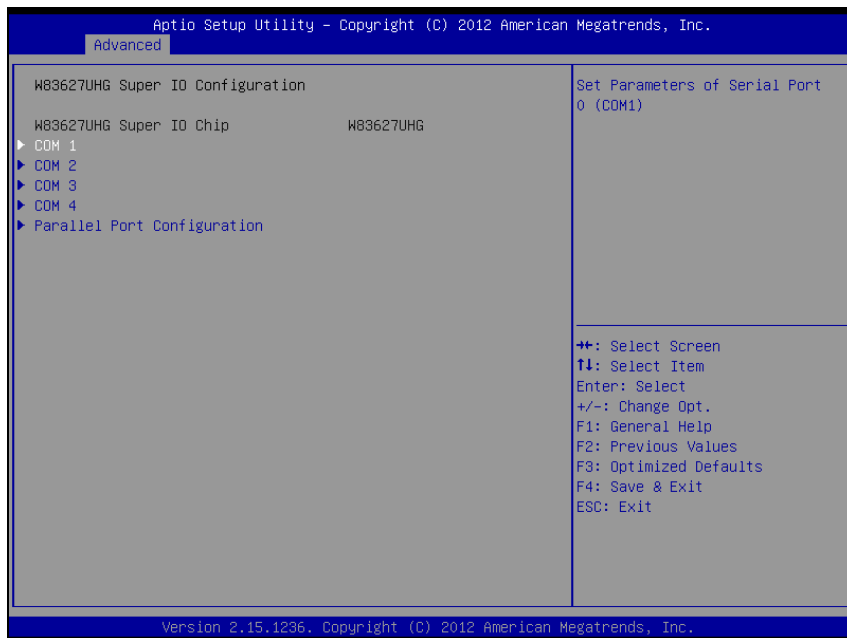

W83627UHG Super IO Configuration screen

BIOS Setting	Options	Description/Purpose
Super IO Chip	No changeable options	Displays the super IO chip model and its manufacturer.
COM 1-4	Enter	Set Parameters of Serial Port 0-3 (COM1-4)
Parallel Port Configuration	Enter	Set Parameters of Parallel Port ( LPT / LPTE )

4-4-6-1. W83627UHG Super IO Configuration – COM 1

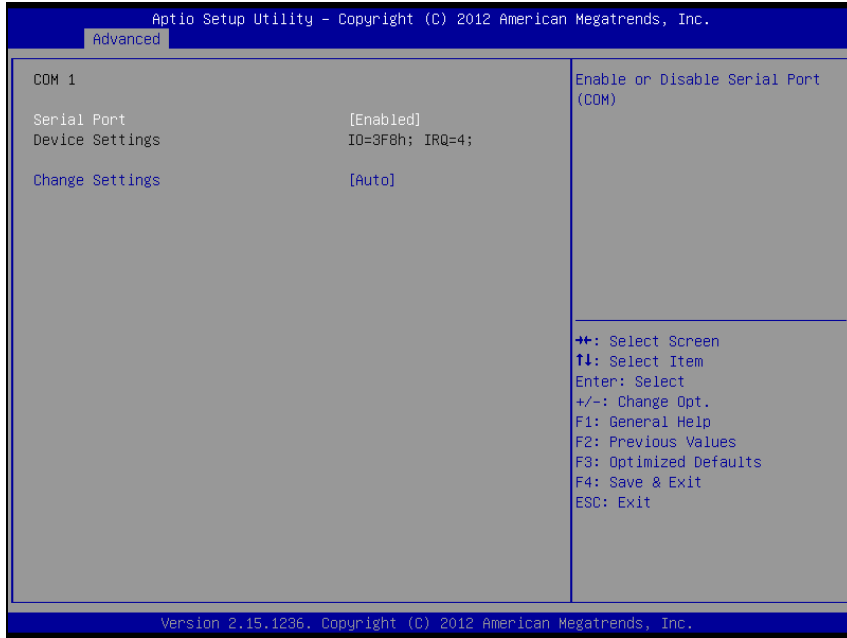

COM 1 Configuration screen

BIOS Setting	Options	Description/Purpose
Serial Port	-Disabled -Enabled	Configures the serial port 1.
Device Settings	No changeable options	Reports the current serial port 1 setting.
Change Settings	-Auto -IO=3F8h; IRQ=4 -IO=3F8h; IRQ=3,4,5,6,7,10,11,12 -IO=2F8h; IRQ=3,4,5,6,7,10,11,12 -IO=3E8h; IRQ=3,4,5,6,7,10,11,12 -IO=2E8h; IRQ=3,4,5,6,7,10,11,12	Specifies the base I/O address and interrupt request for the serial port 1 if enabled.

4-4-6-2. W83627UHG Super IO Configuration – COM 2

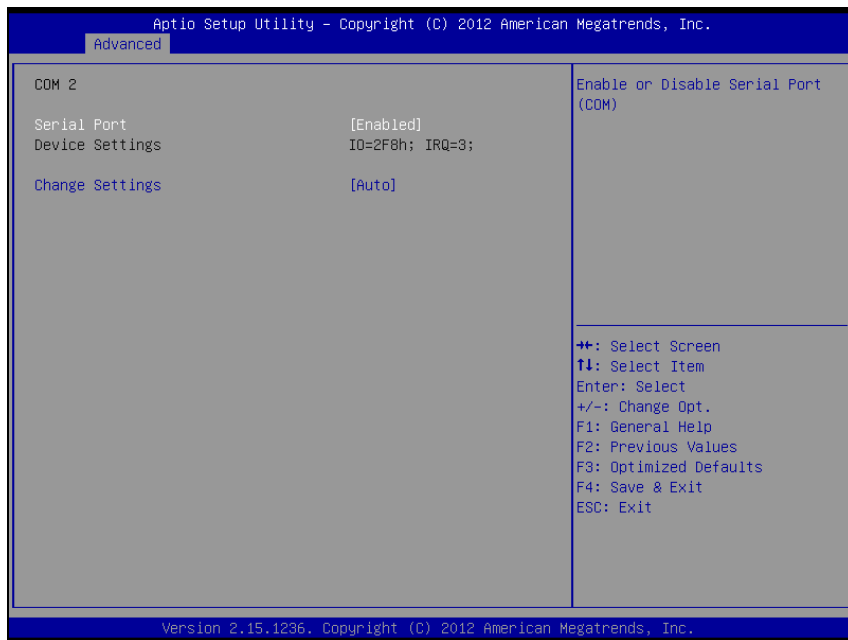

COM 2 Configuration screen

BIOS Setting	Options	Description/Purpose
Serial Port	-Disabled -Enabled	Configures the serial port 2.
Device Settings	No changeable options	Reports the current serial port 2 setting.
Change Settings	-Auto -IO=2F8h; IRQ=3 -IO=3F8h; IRQ=3,4,5,6,7,10,11,12 -IO=2F8h; IRQ=3,4,5,6,7,10,11,12 -IO=3E8h; IRQ=3,4,5,6,7,10,11,12 -IO=2E8h; IRQ=3,4,5,6,7,10,11,12	Specifies the base I/O address and interrupt request for the serial port 2 if enabled.



4-4-6-3. W83627UHG Super IO Configuration – COM 3

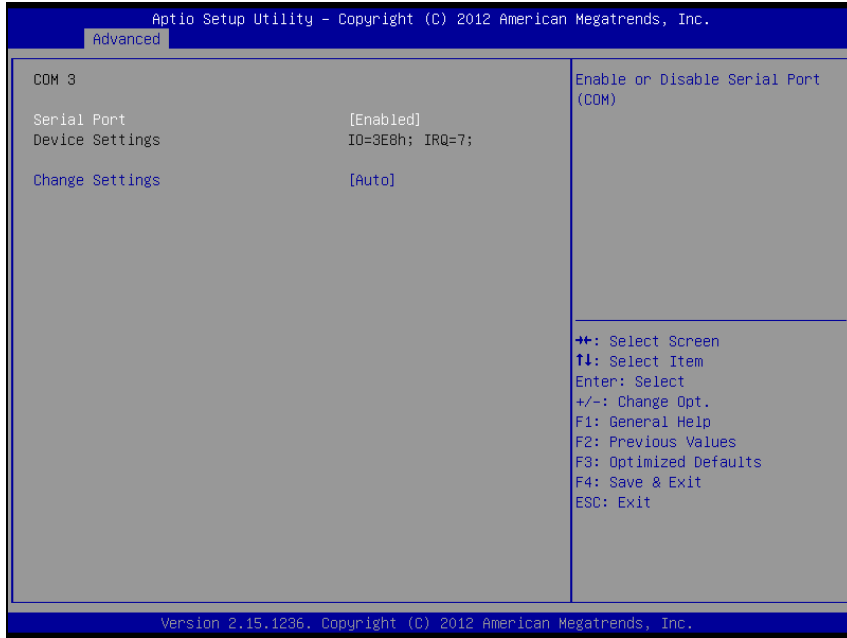

COM 3 Configuration screen

BIOS Setting	Options	Description/Purpose
Serial Port	-Disabled -Enabled	Configures the serial port 3.
Device Settings	No changeable options	Reports the current serial port 3 setting.
Change Settings	-Auto -IO=3E8h; IRQ=7 -IO=3F8h; IRQ=3,4,5,6,7,10,11,12 -IO=2F8h; IRQ=3,4,5,6,7,10,11,12 -IO=3E8h; IRQ=3,4,5,6,7,10,11,12 -IO=2E8h; IRQ=3,4,5,6,7,10,11,12	Specifies the base I/O address and interrupt request for the serial port 3 if enabled.

4-4-6-4. W83627UHG Super IO Configuration – COM 4

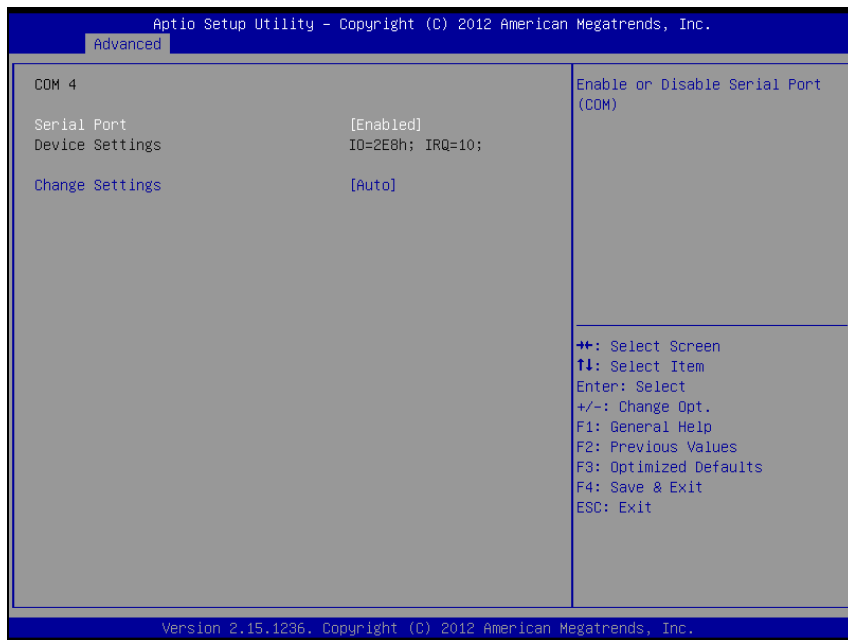

COM 4 Configuration screen

BIOS Setting	Options	Description/Purpose
Serial Port	-Disabled -Enabled	Configures the serial port 4.
Device Settings	No changeable options	Reports the current serial port 4 setting.
Change Settings	-Auto -IO=2E8h; IRQ=10 -IO=3F8h; IRQ=3,4,5,6,7,10,11,12 -IO=2F8h; IRQ=3,4,5,6,7,10,11,12 -IO=3E8h; IRQ=3,4,5,6,7,10,11,12 -IO=2E8h; IRQ=3,4,5,6,7,10,11,12	Specifies the base I/O address and interrupt request for the serial port 4 if enabled.

4-4-6-5. W83627UHG Super IO Configuration – Parallel Port Configuration

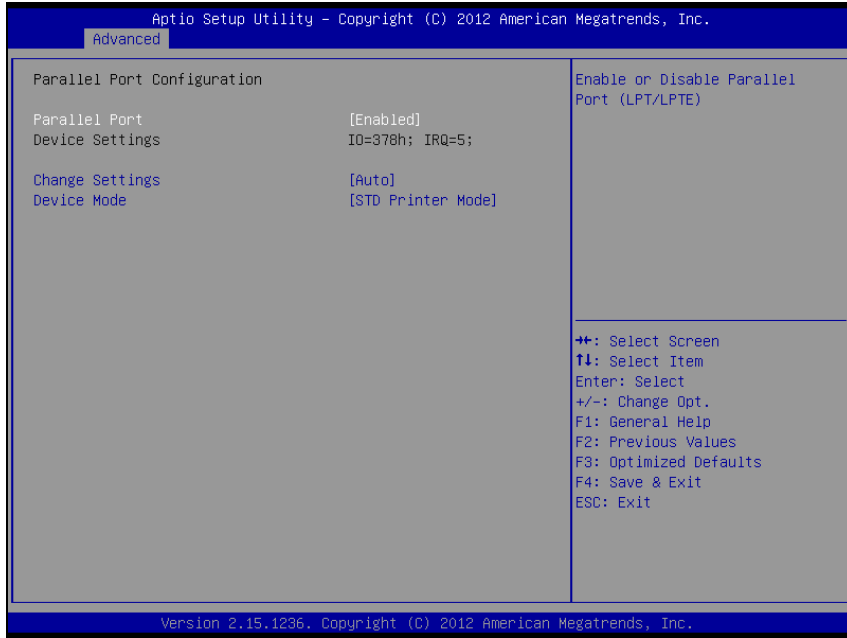

Parallel Port Configuration screen

BIOS Setting	Options	Description/Purpose
Parallel Port	-Disabled -Enabled	Configures the parallel port.
Device Settings	No changeable options	Reports the current parallel port setting.
Change Settings	-Auto -IO=378h; IRQ=5 -IO=378h; IRQ=5,6,7,10,11,12 -IO=278h; IRQ=5,6,7,10,11,12 -IO=3BCh; IRQ=5,6,7,10,11,12 -IO=378h; -IO=278h; -IO=3BCh;	Specifies the base I/O address and interrupt request for the parallel port if enabled.

<b>BIOS Setting</b>	<b>Options</b>	<b>Description/Purpose</b>
Device Mode	-STD Printer Mode -SPP Mode -EPP-1.9 and SPP Mode -EPP-1.7 and SPP Mode -ECP Mode -ECP and EPP 1.9 Mode -ECP and EPP 1.7 Mode	Selects the mode for the parallel port. Not available if the parallel port is disabled. <ul style="list-style-type: none"><li>▪ SPP is Standard Parallel Port mode, a bi-directional mode for printers.</li><li>▪ EPP is Enhanced Parallel Port mode, a high-speed bi-directional mode for non-printer peripherals.</li><li>▪ ECP is Enhanced Capability Port mode, a high-speed bi-directional mode for printers and scanners.</li></ul>

4-4-7. Advanced – W83627UHG HW Monitor

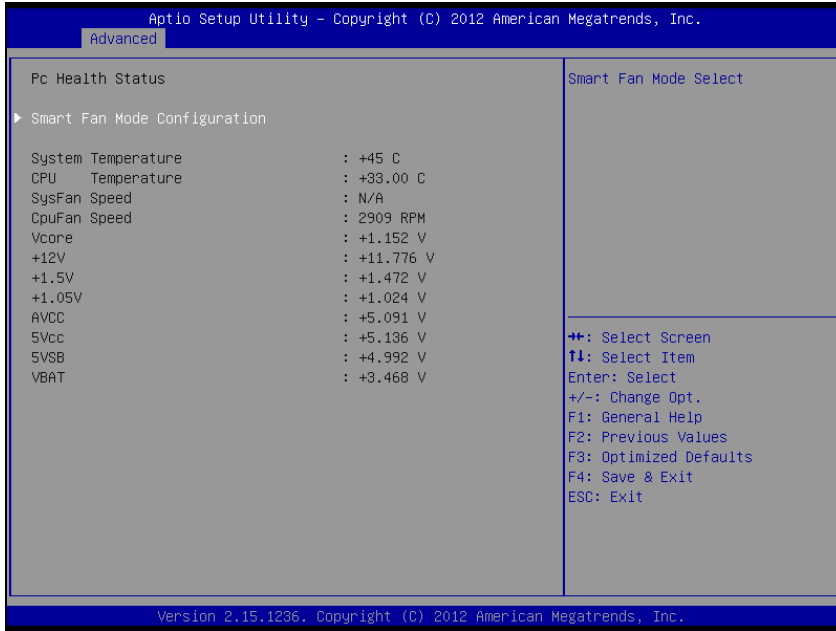

W83627UHG HW Monitor screen

BIOS Setting	Options	Description/Purpose
Smart Fan Mode Configuration	Enter	Smart Fan Mode Select
System Temperature	No changeable options	Displays temperature in the remote thermal sensor zone.
CPU Temperature	No changeable options	Displays processor's temperature.
System Fan Speed	No changeable options	Displays fan speed of the chassis fan.
CPU Fan Speed	No changeable options	Displays fan speed of the CPU fan.
VCORE	No changeable options	Displays voltage level of the +VCORE in supply.
+12V	No changeable options	Displays voltage level of the +12V in supply.
+1.5V	No changeable options	Displays voltage level of the +1.5V in supply.

<b>BIOS Setting</b>	<b>Options</b>	<b>Description/Purpose</b>
+1.05V	No changeable options	Displays voltage level of the +1.5V in supply.
AVCC	No changeable options	Displays voltage level of the AVCC in supply.
5Vcc	No changeable options	Displays voltage level of the 5Vcc in supply.
5VSB	No changeable options	Displays voltage level of the +5VSB in supply.
VBAT	No changeable options	Displays voltage level of the backup CMOS battery.

4-4-7-1. W83627UHG HW Monitor – Smart Fan Mode Configuration

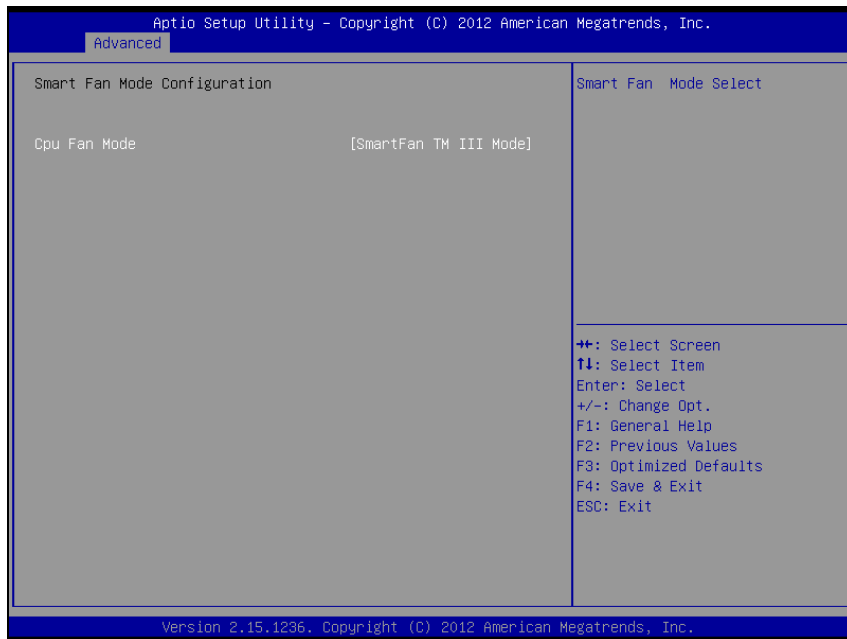

Smart Fan Mode Configuration screen

BIOS Setting	Options	Description/Purpose
Cpu Fan Mode	-Manual Mode -SmartFan TM III Mode	Select SmartFan mode
Cpu Fan PWM Output Duty	0~255	Cpu fan PWM output value, rang 0~255

4-4-8. Advanced – Watchdog Configuration

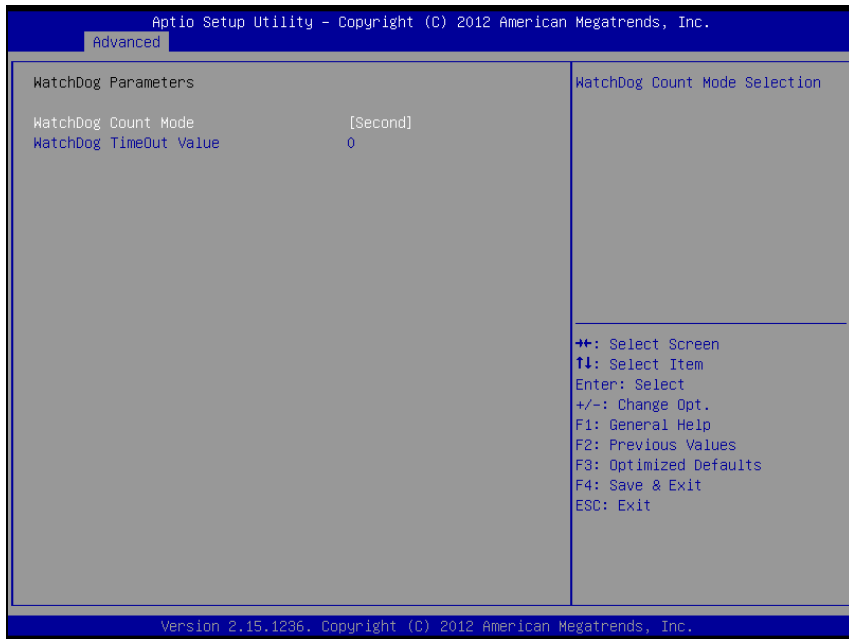

Watchdog Configuration screen

BIOS Setting	Options	Description/Purpose
WatchDog Count Mode	-Second	Unit for watchdog timer.
WatchDog TimeOut value	Multiple options ranging from 0 to 255	Sets the desired value for watchdog timer.



## 4-5. Chipset

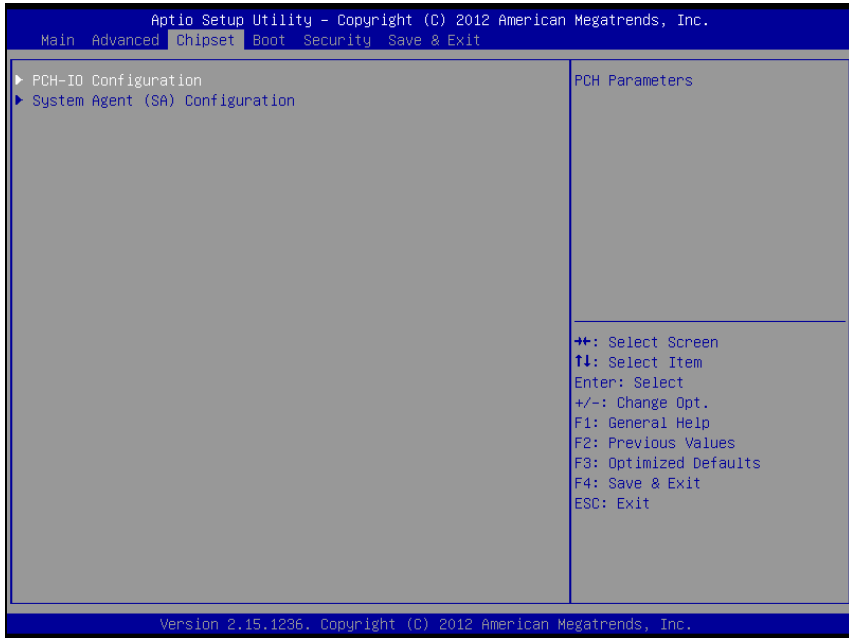

Chipset screen

4-5-1. Chipset – PCH IO Configuration

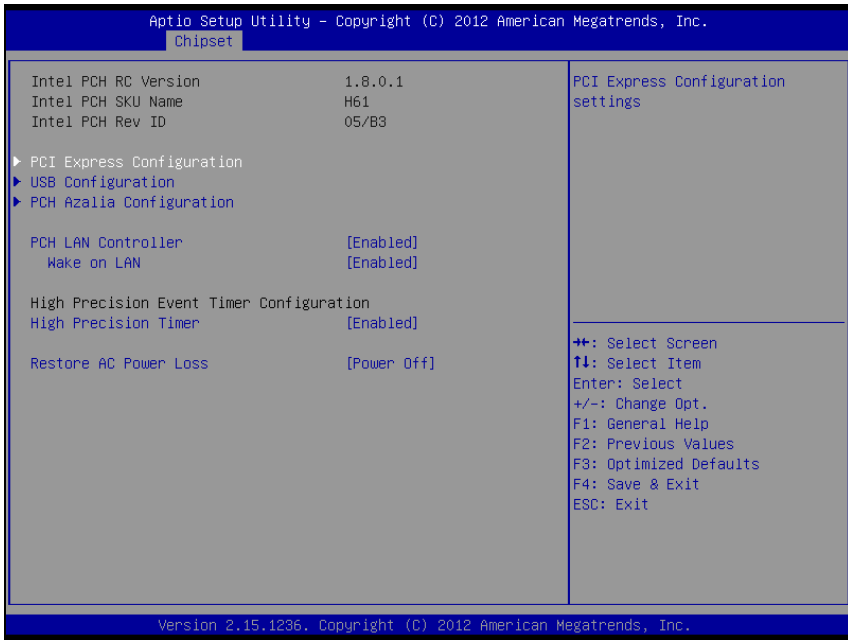

PCH IO Configuration screen

BIOS Setting	Options	Description/Purpose
PCI Express Configuration	Enter	PCI Express Configuration settings
USB Configuration	Enter	USB configuration settings
PCH Azalia Configuration	Enter	PCH Azalia Configuration settings
PCH LAN Controller	-Disabled -Enabled	Enable or disable onboard NIC
Wake on LAN	-Disabled -Enabled	Enable or disable integrated LAN to wake the system. (The Wake On LAN cannot be disabled if ME is on at Sx state)

<b>BIOS Setting</b>	<b>Options</b>	<b>Description/Purpose</b>
High Precision Timer	-Disabled -Enabled	Enable or Disable the high precision event timer.
Restore AC Power Loss	-Power off -Power on	Select AC power state when power is re-applied after a power failure

### 4-5-1-1. PCH IO Configuration – PCI Express Configuration

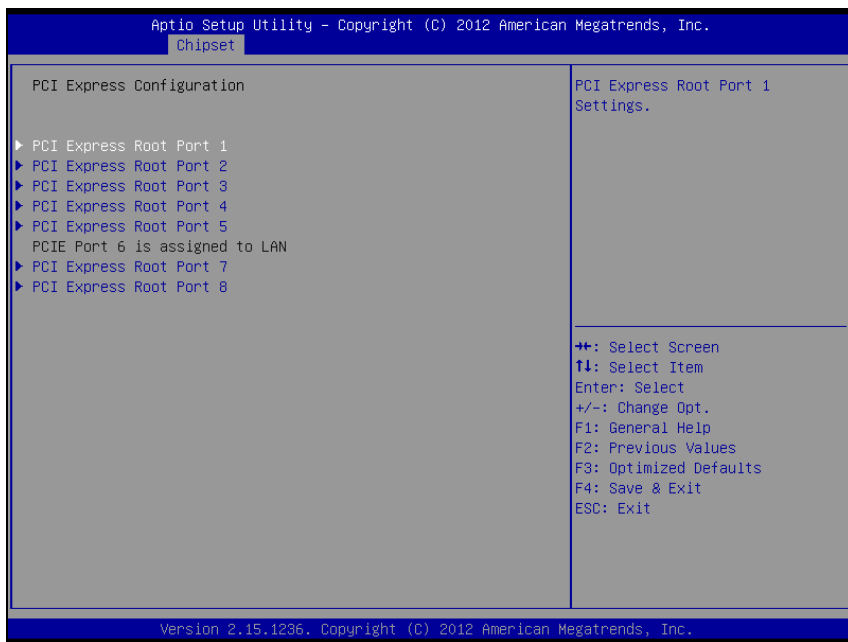

**PCI Express Configuration screen**

BIOS Setting	Options	Description/Purpose
PCI Express Root Port 1-8	Enter	PCI Express Root Port 1-8 settings

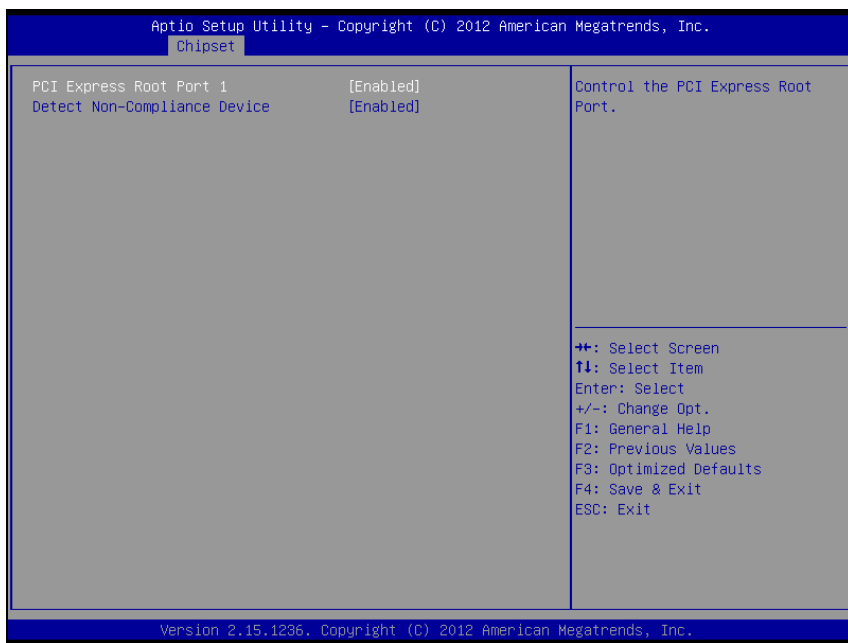

PCI Express Express Root Port screen

BIOS Setting	Options	Description/Purpose
PCI Express Root Port 1-8	-Disabled -Enabled	Control the PCI Express Root Port
Detect Non-Compliance Device	-Disabled -Enabled	Detect Non-Compliance PCI Express Device. If enable, it will take more time at POST time.

4-5-1-2. PCH IO Configuration – USB Configuration

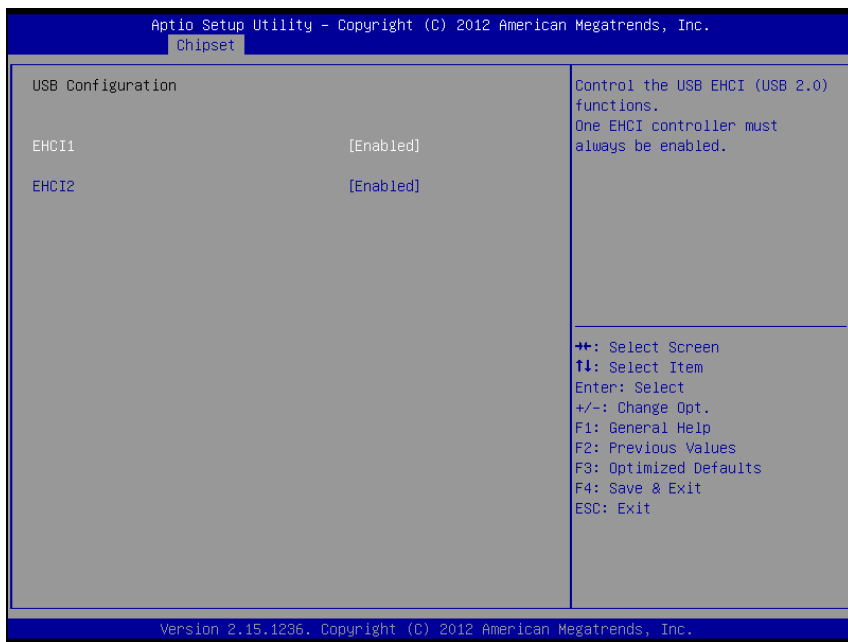

USB Configuration screen

BIOS Setting	Options	Description/Purpose
EHCI1	-Disabled	Control the USB EHCI (USB 2.0) functions. One EHCI controller must always be enabled.
	-Enabled	
EHCI2	-Disabled	
	-Enabled	

4-5-1-3. PCH IO Configuration – PCH Azalia Configuration

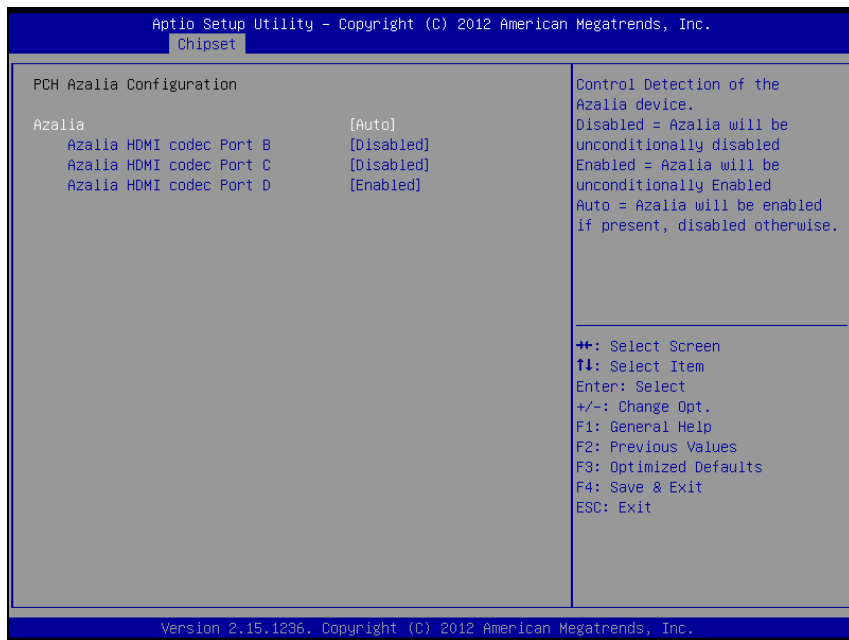

PCH Azalia Configuration screen

BIOS Setting	Options	Description/Purpose
Azalia	-Auto -Disabled -Enabled	Control Detection of the Azalia device.
Azalia HDMI codec Port B	-Disabled -Enabled	Enable or disable internal HDMI codec Port for Azalia.
Azalia HDMI codec Port C	-Disabled -Enabled	Enable or disable internal HDMI codec Port for Azalia.
Azalia HDMI codec Port D	-Disabled -Enabled	Enable or disable internal HDMI codec Port for Azalia.

### 4-5-2. Chipset – System Agent (SA) Configuration

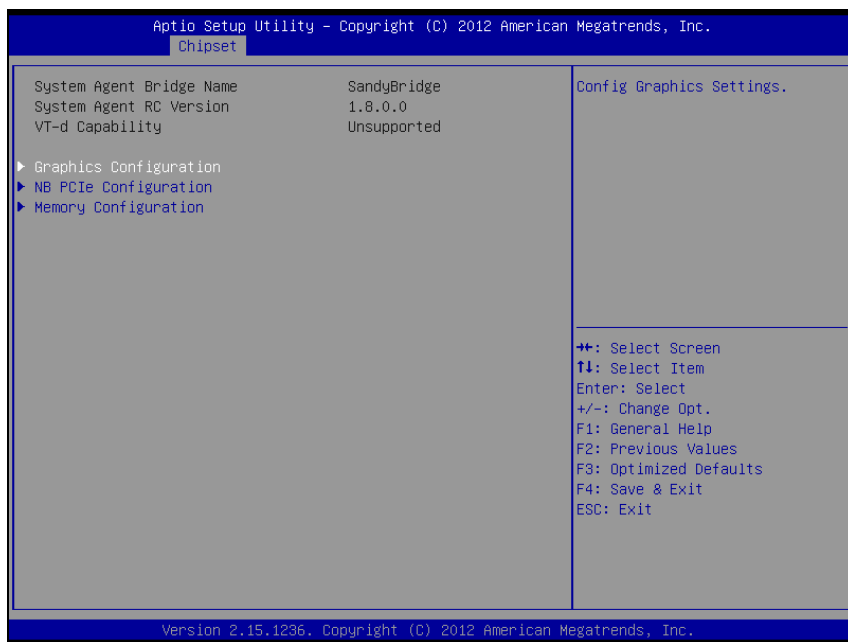

**System Agent screen**

BIOS Setting	Options	Description/Purpose
Graphics Configuration	Enter	Config Graphics Settings
NB PCIe Configuration	Enter	Config NB PCIE Settings
Memory Configuration	Enter	Config Memory Parameters



4-5-2-1. System Agent Configuration – Graphics Configuration

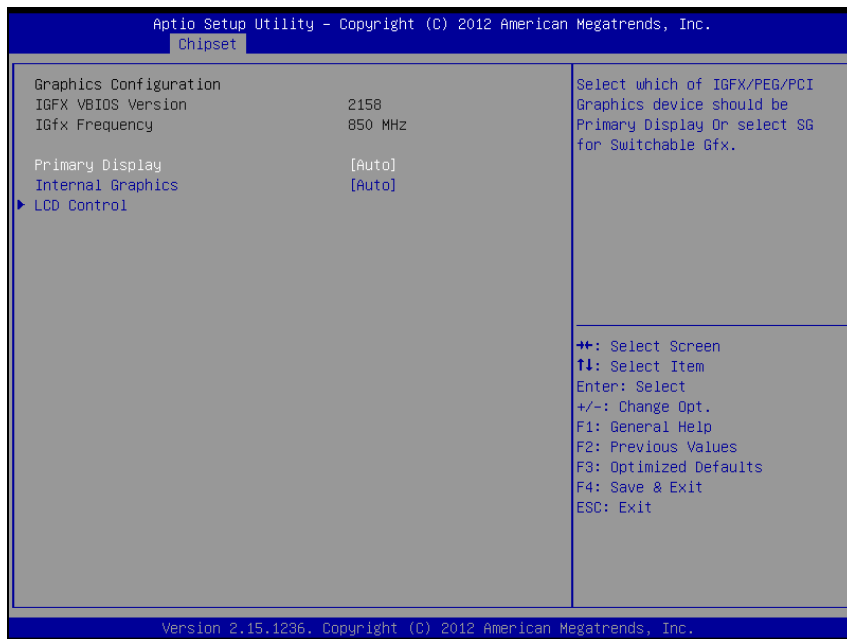

Graphics Configuration screen

BIOS Setting	Options	Description/Purpose
Primary Display	-Auto -IGFX -PEG -PCI -SG	Select which of IGFX/PEG/PCI Graphics device should be Primary Display Or select SG for switchable Gfx.
Internal Graphics	-Auto -Disabled -Enabled	Keep IGD enabled based on the setup options.
LCD Control	Enter	LCD Control

4-5-2-2. Graphics Configuration – LCD Control

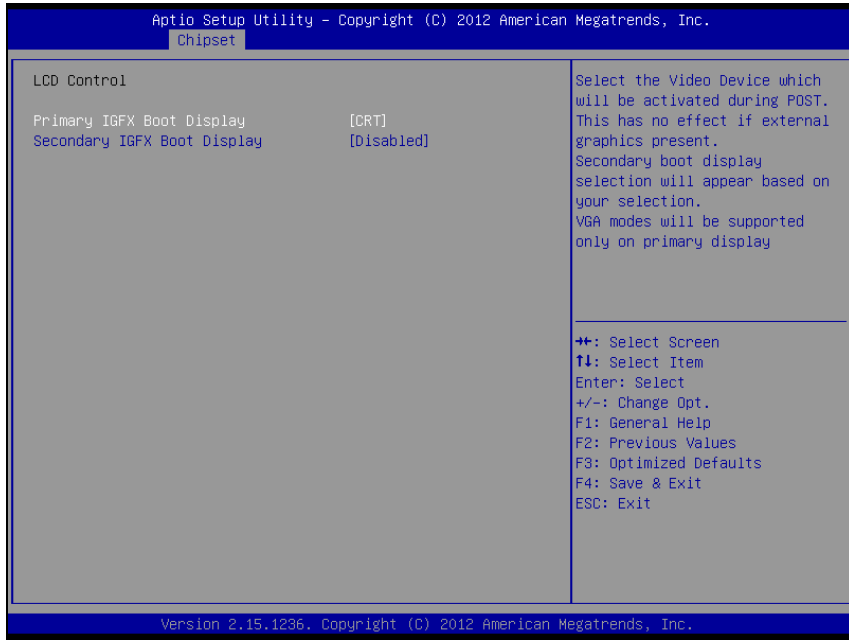

LCD Control screen

BIOS Setting	Options	Description/Purpose
Primary IGFX Boot Display	-VBIOS Default -CRT -EFP -LFP -EFP3 -EFP2 -LFP2	Select the video Device which will be activated during POST. This has no effect if external graphics present. Secondary boot display selection will appear based on your selection. VGA modes will be supported only on primary display.
Secondary IGFX Boot Display	-Disabled -CRT -EFP -LFP -EFP3 -EFP2 -LFP2	Select secondary Display Device.

4-5-2-3. Graphics Configuration – NB PCIe Configuration

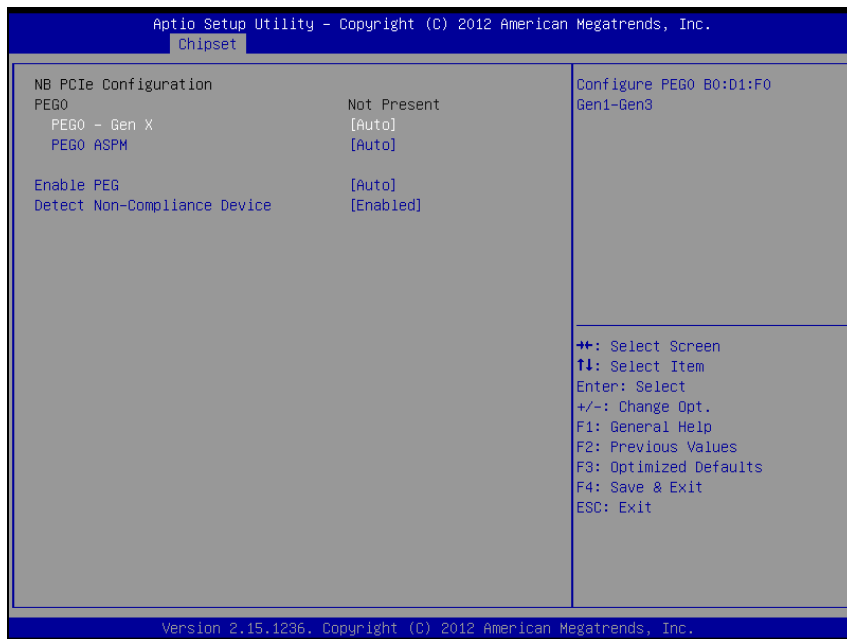

NB PCIe Configuration screen

BIOS Setting	Options	Description/Purpose
PEG0 – Gen x	-Auto -Gen1 -Gen2 -Gen3	Configure PEG0 B0:D1:F0 Gen1-Gen3
PEG0 ASPM	-Auto -Disabled -ASPM L0s -ASPM L1 -ASPM L0sL1	Control ASPM support for the PEG: Device 1 Function 0. This has no effect if PEG is not the currently active device.
Enable PEG	-Auto -Disabled -Enabled	To enable or disable the PEG

<b>BIOS Setting</b>	<b>Options</b>	<b>Description/Purpose</b>
Detect Non-Compliance Device	-Disabled -Enabled	Detect Non-Compliance PCI Express Device in PEG.

4-5-2-4. Graphics Configuration – Memory Configuration

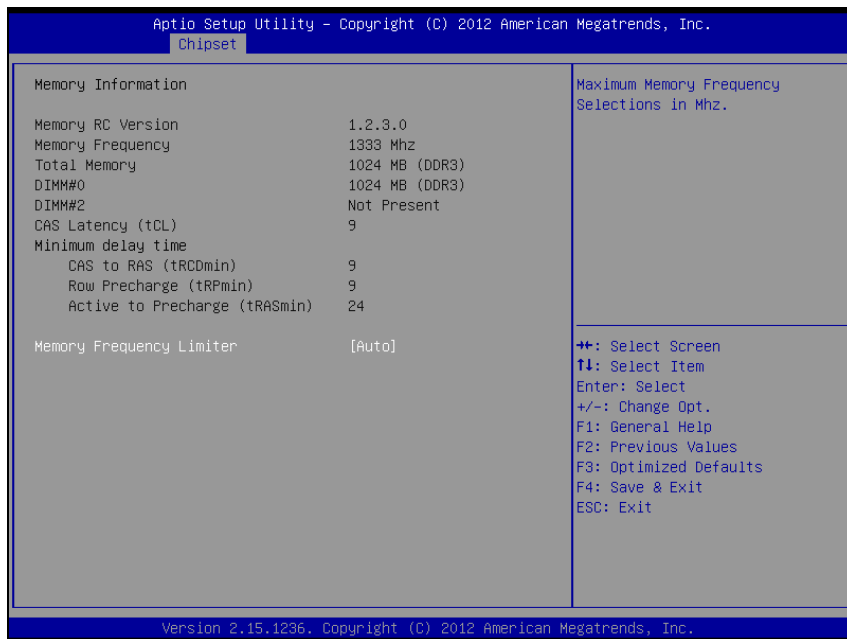

Memory Configuration screen

BIOS Setting	Options	Description/Purpose
Memory Frequency Limiter	-Auto -1067 -1333 -1600 -1867 -2133 -2400 -2667	Maximum Memory Frequency Selections in Mhz.

## 4-6. Boot

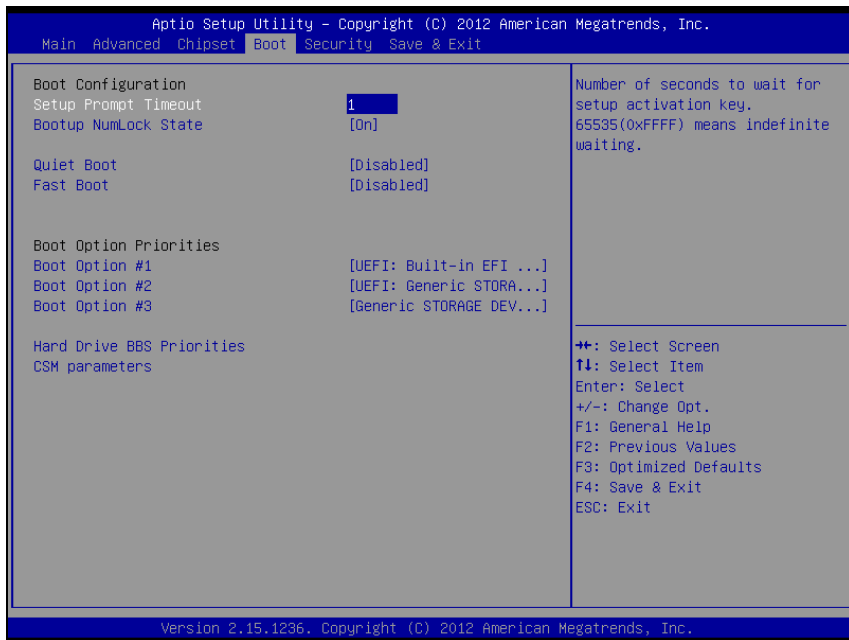

Boot screen

BIOS Setting	Options	Description/Purpose
Setup Prompt Timeout	1-65535	Number of seconds to wait for setup activation key. 65535 (0xFFFF) means indefinite waiting.
Bootup NumLock Status	-On -Off	Specifies the power-on state of the numlock feature on the numeric keypad of keyboard.
Quiet Boot	-Disabled -Enabled	When quiet boot is enabled, it displays OEM logo instead of POST messages during boot.
Fast Boot	-Disabled -Enabled	Enables or disables boot with initialization of a minimal set of devices required to launch active boot option. Has no effect for BBS boot options.

<b>BIOS Setting</b>	<b>Options</b>	<b>Description/Purpose</b>
Hard Dirve BBS Priorities	Enter	Set the order of the legacy devices in this group.
CSM parameters	Enter	OpROM execution, boot options filter, etc.

### 4-6-1. Boot – Hard Drive BBS Priorities

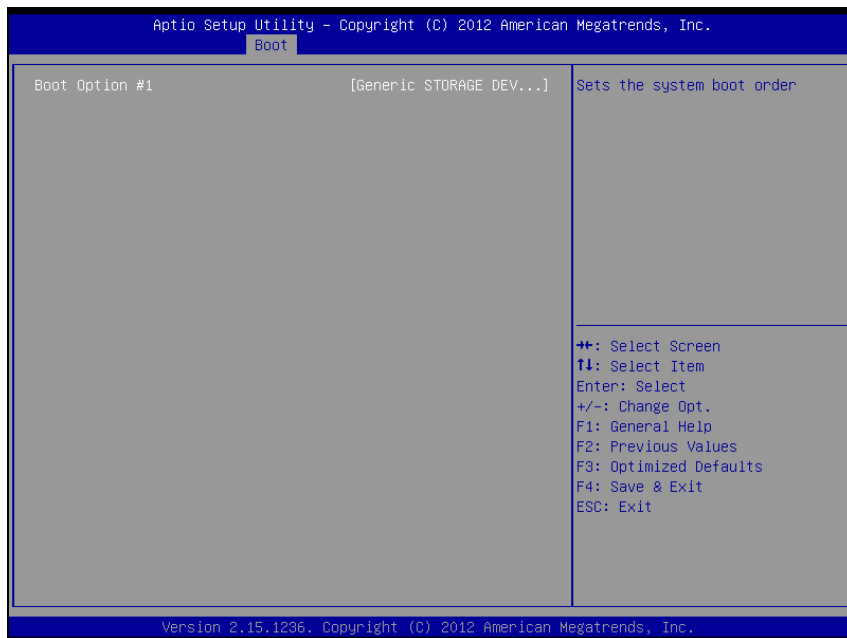

Hard Drive BBS Priorities screen

BIOS Setting	Options	Description/Purpose
Boot Option #1	-[drive(s)] -Disabled	Allows setting the boot order of available drive(s).



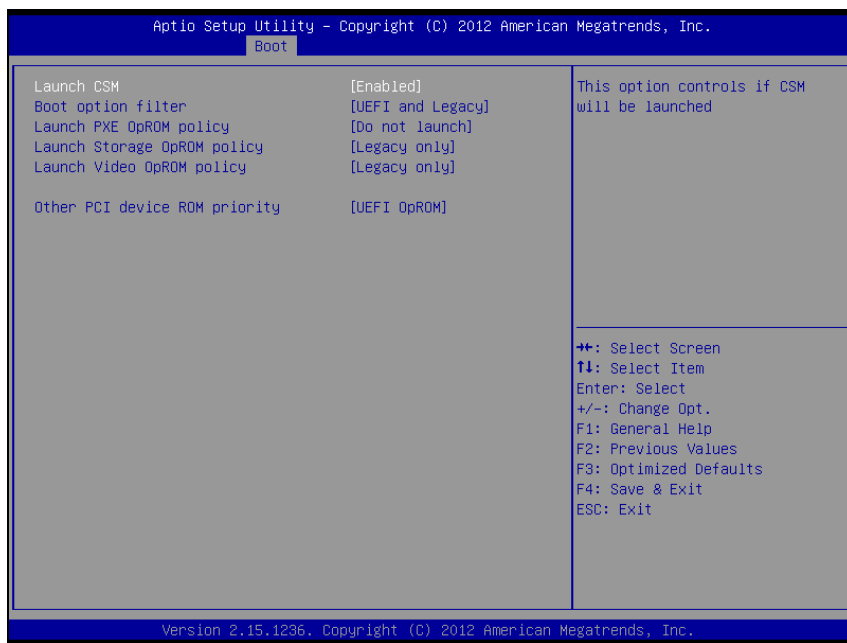

Hard Drive BBS Priorities screen

BIOS Setting	Options	Description/Purpose
Launch CSM	-Disabled -Enabled	This option controls if CSM will be launched.
Boot option filter	-UEFI and Legacy -Legacy only -UEFI only	This option controls what devices system can boot to.
Launch PXE OpROM policy	-Do not launch -UEFI only -Legacy only	Controls the execution of UEFI and Legacy PXE OpROM.
Launch Storage OpROM Policy	-Do not launch -UEFI only -Legacy only	Controls the execution of UEFI and Legacy Storage OpROM.

<b>BIOS Setting</b>	<b>Options</b>	<b>Description/Purpose</b>
Launch Video OpROM policy	-Do not launch -UEFI only -Legacy only -Legacy first -UEFI first	Controls the execution of UEFI and Legacy Video OpROM
Other PCI device ROM priority	-UEFI OpROM -Legacy OpROM	For PCI devices other than Network, Mass storage or Video defines which OpROM to launch.

## 4-7. Security

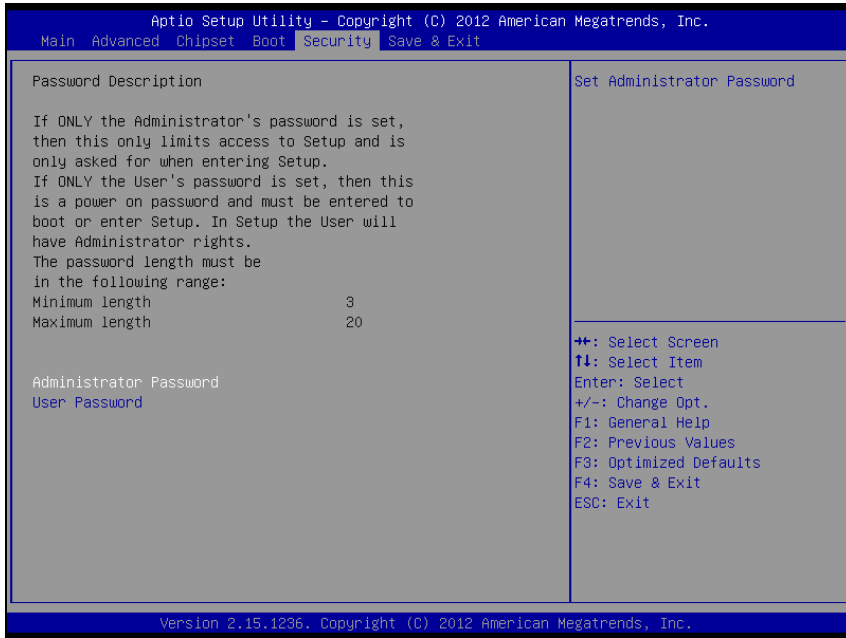

Security screen

BIOS Setting	Options	Description/Purpose
Administrator Password	Password can be up to 20 alphanumeric characters.	Specifies the administrator password.
User Password	Password can be up to 20 alphanumeric characters.	Specifies the user password.

## 4-8. Save & Exit

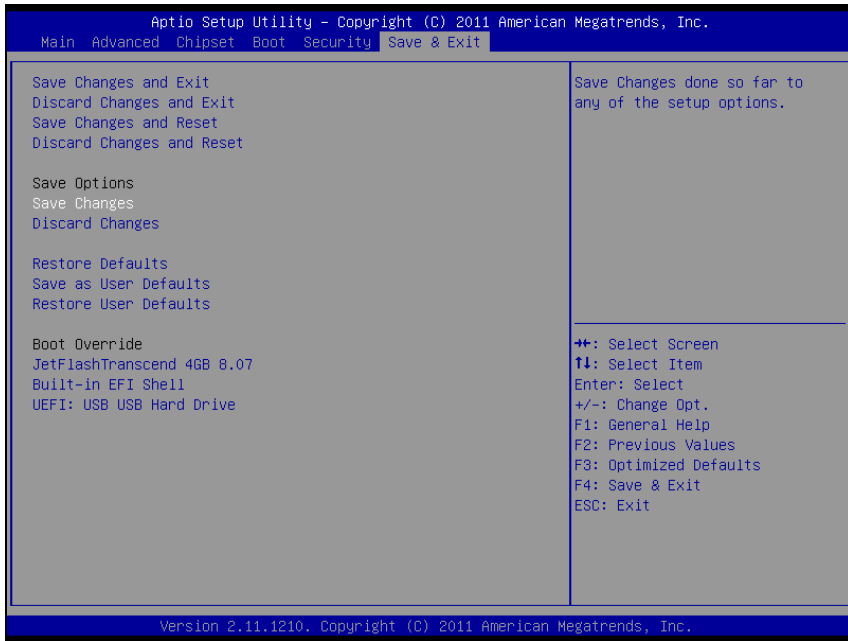

Save & Exit screen

BIOS Setting	Options	Description/Purpose
Save Changes and Exit	No changeable options	Exits and saves the changes in CMOS SRAM.
Discard Changes and Exit	No changeable options	Exits without saving any changes made in BIOS settings.
Save Changes and Reset	No changeable options	Saves the changes in CMOS SRAM and resets.
Discard Changes and Reset	No changeable options	Resets without saving any changes made in BIOS settings.
Save Changes	No changeable options	Saves the changes done in BIOS settings so far.
Discard Changes	No changeable options	Discards the changes done in BIOS settings so far.

<b>BIOS Setting</b>	<b>Options</b>	<b>Description/Purpose</b>
Restore Defaults	No changeable options	Loads the optimized defaults for BIOS settings.
Save as User Defaults	No changeable options	Saves the current values as user defaults.
Restore User Defaults	No changeable options	Loads the user defaults for BIOS settings.
Boot Override	-[drive(s)]	Forces to boot from selected [drive(s)].

# ***SYSTEM ASSEMBLY***

*APPENDIX*

***A***

This appendix contains the exploded diagram of the SA-5872 system.

Section includes:

- Exploded Diagram for the Whole System

**EXPLODED DIAGRAM FOR THE WHOLE SYSTEM**

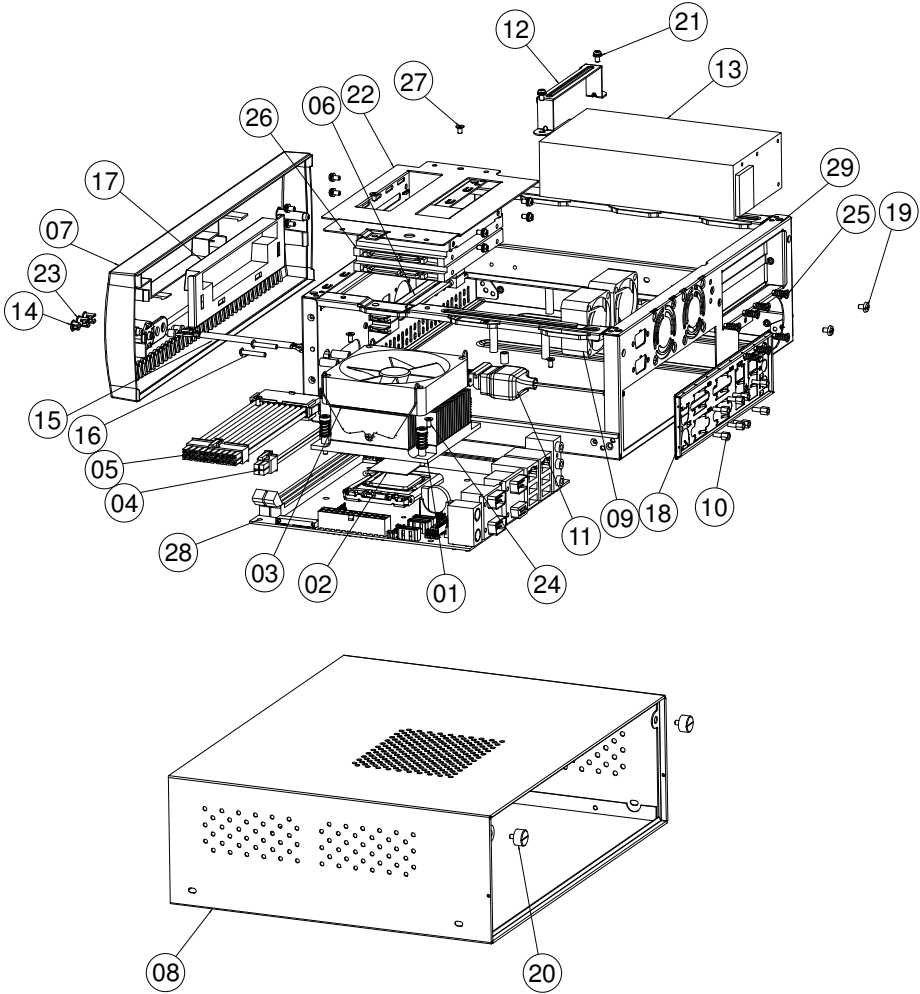

NO.	COMPONENT NAME	PART NO.	Q'TY
1	HEAT SINK	21-002-19090004	1
2	THERMAL PAD	81-006-83030002	1
3	DC FAN	21-004-08080132	1
4	POWER CABLE	27-012-00003071	1
5	POWER CABLE(20M to 20F)	27-012-00002073	1
6	MINI SATA LOCK CABLE	27-008-22704031	2
7	FRONT PANEL STD	30-003-08610006	1
8	TOP CHASSIS	20-015-03061272	1
9	SYSTEM FAN	21-004-04040369	1
10	HEX CU BOSS	22-692-40048051	8
11	POWER SWITCH CABLE	27-019-25104071	1
12	POWER SUPPLY HOLDER	20-029-03001082	1
13	POWER SUPPLY	52-001-23220601	1
14	HOLD PLUG	30-054-04100000	1
15	LED CABLE	27-018-08204071	1
16	PAN HEAD SCREW	22-222-30018011	2
17	FRONR PANEL CD-ROM FDD LID	30-003-08410006	1
18	I/O SHIELD	80-010-07001212	1
19	PAN HEAD SCREW	22-622-60005011	2
20	HANDEL HEAD SCREW	22-382-06005031	2
21	SPRING WASHER SCREW	22-232-30060211	10
22	DRIVER BAY	20-006-03001203	1
23	LED HOUSING	30-014-04100009	2
24	FLAT HEAD SCREW	22-215-30060011	4
25	FLAT HEAD SCREW	82-712-47011018	8
26	2.5" SATA HDD	SEE ORDER	2
27	FLAT HEAD SCREW	22-212-30005311	2
28	PCBA	BM-0872	1
29	INNER CHASSIS ASSY	20-015-03001272	1



# ***TECHNICAL SUMMARY***

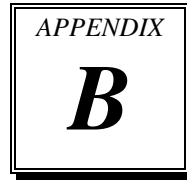

This section introduce you the maps concisely.

Sections included:

- Block Diagram
- Interrupt Map
- DMA Channel Map
- I/O Map
- Memory Map
- Watchdog Timer Configuration
- Flash BIOS Update

**BLOCK DIAGRAM**

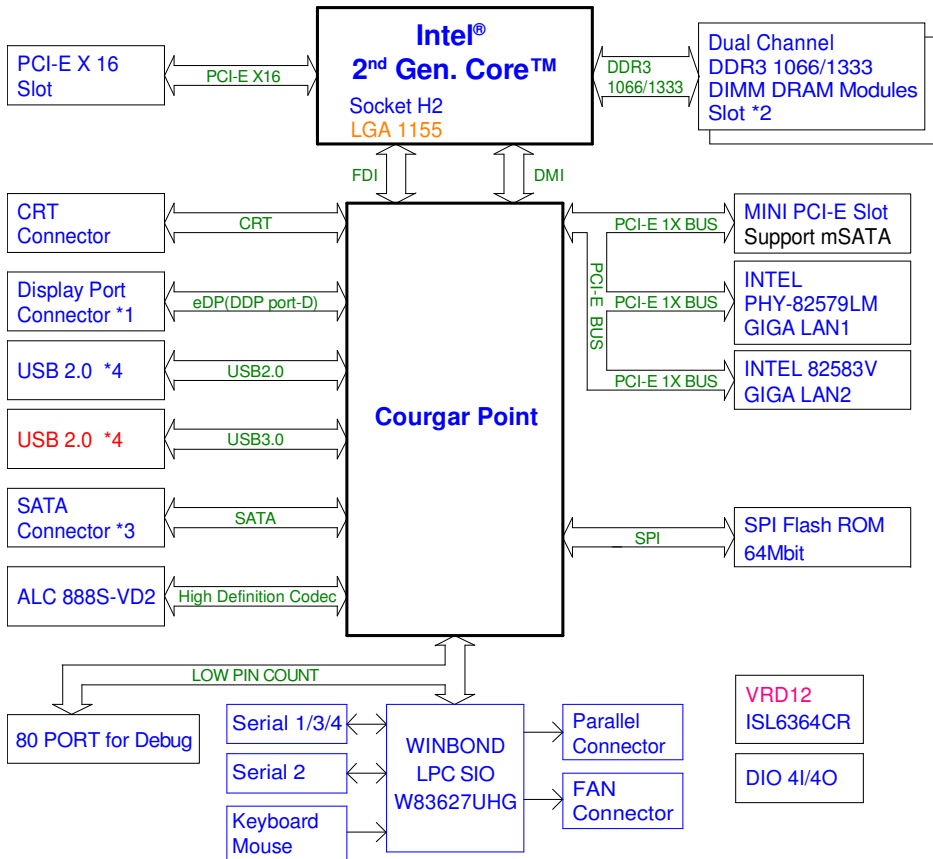

## INTERRUPT MAP

IRQ	ASSIGNMENT
0	System timer
1	Standard 101/102-Key or Microsoft Natural PS/2 Keyboard
3	Communications Port (COM2)
4	Communications Port (COM1)
5	Parallel Port(LPT)
7	Communications Port (COM3)
8	System CMOS/real time clock
9	Microsoft ACPI-Compliant System
10	Communications Port (COM4)
10	Intel® 6 Series/C200 Series Chipset Family SMBus Controller
12	Microsoft PS/2 Mouse
13	Numeric data processor
14	Secondary IDE Channel
16	Intel® HD Graphics Family
16	Intel® Management Engine Interface
16	Intel® 6 Series/C200 Series Chipset Family USB Enhanced Host Controller
17	Intel® 6 Series/C200 Series Chipset Family PCI Express Root Port 1
18	Standard dual channel PCI IDE controller
18	Intel® 6 Series/C200 Series Chipset Family PCI Express Root Port 3
18	Intel® 82583V Gigabit Network Connection
19	Intel® 6 Series/C200 Series Chipset Family 2 port Serial ATA Storage Controller
20	Intel® 82579LM Gigabit Network Connection
22	Microsoft UAA Bus Driver for High Definition Audio
23	Intel® 6 Series/C200 Series Chipset Family USB Enhanced Host Controller

## **DMA CHANNELS MAP**

<b>TIMER CHANNEL</b>	<b>ASSIGNMENT</b>
Channel 2	Standard FDC Controller
Channel 4	Direct memory access controller

## I/O MAP

I/O MAP	ASSIGNMENT
0x00000000-0x000003AF	PCI bus
0x00000000-0x000003AF	Direct memory access controller
0x00000010-0x0000001F	Motherboard resources
0x00000020-0x00000021	Programmable interrupt controller
0x00000022-0x0000003F	Motherboard resources
0x00000040-0x00000043	System timer
0x00000044-0x0000005F	Motherboard resources
0x00000060-0x00000060	Standard 101/102-Key or Microsoft Natural PS/2 Keyboard
0x00000061-0x00000061	System speaker
0x00000062-0x00000063	Motherboard resources
0x00000064-0x00000064	Standard 101/102-Key or Microsoft Natural PS/2 Keyboard
0x00000065-0x0000006F	Motherboard resources
0x00000070-0x00000071	System CMOS/real time clock
0x00000072-0x0000007F	Motherboard resources
0x00000080-0x00000080	Motherboard resources
0x00000081-0x00000083	Direct memory access controller
0x00000084-0x00000086	Motherboard resources
0x00000087-0x00000087	Direct memory access controller
0x00000088-0x00000088	Motherboard resources
0x00000089-0x0000008B	Direct memory access controller
0x0000008C-0x0000008E	Motherboard resources
0x0000008F-0x0000008F	Direct memory access controller
0x00000090-0x0000009F	Motherboard resources
0x000000A0-0x000000A1	Programmable interrupt controller
0x000000A2-0x000000BF	Motherboard resources
0x000000C0-0x000000DF	Direct memory access controller
0x000000E0-0x000000EF	Motherboard resources
0x000000F0-0x000000FF	Numeric data processor

<b>I/O MAP</b>	<b>ASSIGNMENT</b>
0x00000170-0x00000177	Secondary IDE channel
0x000001F0-0x000001F7	Primary IDE channel
0x00000274-0x00000277	ISAPNP Read Data Port
0x00000279-0x00000279	ISAPNP Read Data Port
0x00000295-0x00000296	Motherboard resources
0x000002E8-0x000002EF	Communications Port (COM4)
0x000002F8-0x000002FF	Communications Port (COM2)
0x00000376-0x00000376	Secondary IDE Channel
0x00000378-0x0000037F	Printer Port (LPT1)
0x000003B0-0x000003DF	PCI bus
0x000003B0-0x000003DF	Intel® HD Graphics Family
0x000003C0-0x000003DF	Intel® HD Graphics Family
0x000003E0-0x00000CF7	PCI bus
0x000003E8-0x000003EF	Communications Port (COM3)
0x000003F6-0x000003F6	Primary IDE Channel
0x000003F7-0x000003F7	Standard FDC controller
0x000003F8-0x000003FF	Communications Port (COM1)
0x00000400-0x00000453	System board
0x00000454-0x00000457	Motherboard resources
0x00000458-0x0000047F	System board
0x000004D0-0x000004D1	Motherboard resources
0x00000500-0x0000057F	System board
0x00000778-0x0000077F	Motherboard resources
0x00000A79-0x00000A79	ISAPNP Read Data Port
0x00000D00-0x0000FFFF	PCI bus
0x00001180-0x0000119F	System board
0x0000E000-0x0000EFFF	Intel® 6 Series/C200 Series Chipset Family PCI Express Root Port 3
0x0000E000-0x0000EFFF	Intel® 82583V Gigabit Network Connection
0x0000F000-0x0000F03F	Intel® HD Graphics Family
0x0000F040-0x0000F05F	Intel® 6 Series/C200 Series Chipset Family SMBus Controller

<b>I/O MAP</b>	<b>ASSIGNMENT</b>
0x0000F060-0x0000F07F	Intel® 82579LM Gigabit Network Connection
0x0000F080-0x0000F08F	Intel® 6 Series/C200 Series Chipset Family 2 port Serial ATA Storage Controller
0x0000F090-0x0000F09F	Intel® 6 Series/C200 Series Chipset Family 2 port Serial ATA Storage Controller
0x0000F0A0-0x0000F0A3	Intel® 6 Series/C200 Series Chipset Family 2 port Serial ATA Storage Controller
0x0000F0B0-0x0000F0B7	Intel® 6 Series/C200 Series Chipset Family 2 port Serial ATA Storage Controller
0x0000F0C0-0x0000F0C3	Intel® 6 Series/C200 Series Chipset Family 2 port Serial ATA Storage Controller
0x0000F0D0-0x0000F0D7	Intel® 6 Series/C200 Series Chipset Family 2 port Serial ATA Storage Controller
0x0000F0E0-0x0000F0EF	Intel® 6 Series/C200 Series Chipset Family 4 port Serial ATA Storage Controller
0x0000F0F0-0x0000F0FF	Intel® 6 Series/C200 Series Chipset Family 4 port Serial ATA Storage Controller
0x0000F150-0x0000F15F	Standard dual channel PCI IDE controller
0x0000F160-0x0000F163	Standard dual channel PCI IDE controller
0x0000F170-0x0000F177	Standard dual channel PCI IDE controller
0x0000F180-0x0000F183	Standard dual channel PCI IDE controller
0x0000F190-0x0000F197	Standard dual channel PCI IDE controller

## MEMORY MAP

<b>MEMORY MAP</b>	<b>ASSIGNMENT</b>
0xFE000000-0xFE3FFFFFFF	Intel® HD Graphics Family
0xD0000000-0xDFFFFFFF	Intel® HD Graphics Family
0xFE529000-0xFE52900F	Intel® Management Engine Interface
0xFE500000-0xFE51FFFF	Intel® 82579LM Gigabit Network Connection
0xFE527000-0xFE527FFF	Intel® 82579LM Gigabit Network Connection
0xFE526000-0xFE5263FF	Intel® 6 Series/C200 Series Chipset Family USB Enhanced Host Controller
0xFE520000-0xFE523FFF	Microsoft UAA Bus Driver for High Definition Audio
0xFE400000-0xFE4FFFFFFF	Intel® 6 Series/C200 Series Chipset Family PCI Express Root Port 3
0xFE400000-0xFE4FFFFFFF	Intel® 82583V Gigabit Network Connection
0xFE420000-0xFE423FFF	Intel® 82583V Gigabit Network Connection
0xFE525000-0xFE5253FF	Intel® 6 Series/C200 Series Chipset Family USB Enhanced Host Controller
0xFE524000-0xFE5240FF	Intel® 6 Series/C200 Series Chipset Family SMBus Controller
0xFED10000-0xFED19FFF	System board
0xE0000000-0xEFFFFFFF	System board
0xFED90000-0xFED93FFF	System board
0xFED20000-0xFED3FFFF	System board
0xFEE00000-0xFEE0FFFF	System board
0xFED1C000-0xFED1FFFF	System board
0xFEC00000-0xFECFFFFF	System board
0xFED08000-0xFED08FFF	System board
0xFF000000-0xFFFFFFFF	System board
0xFED00000-0xFED003FF	High precision event timer
0xA0000-0xBFFFF	PCI bus
0xA0000-0xBFFFF	Intel® HD Graphics Family
0xC0000-0xDFFFF	PCI bus
0x3DA00000-0xFFFFFFFF	PCI bus



## **WATCHDOG TIMER CONFIGURATION**

The I/O port address of the watchdog timer is 2E (hex) and 2F (hex). 2E (hex) is the address port. 2F (hex) is the data port. User must first assign the address of register by writing address value into address port 2E (hex), then write/read data to/from the assigned register through data port 2F (hex).

### **Configuration Sequence**

To program W83627UHG configuration registers, the following configuration sequence must be followed:

1. Enter the extended function mode
2. Configure the configuration registers
3. Exit the extended function mode

#### **1. Enter the extended function mode**

To place the chip into the Extended Function Mode, two successive writes of 0x87 must be applied to Extended Function Enable Registers (EFERs, i.e. 2Eh or 4Eh).

#### **2. Configure the configuration registers**

The chip selects the Logical Device and activates the desired Logical Devices through Extended Function Index Register (EFIR) and Extended Function Data Register (EFDR). The EFIR is located at the same address as the EFER, and the EFDR is located at address (EFIR+1). First, write the Logical Device Number (i.e. 0x07) to the EFIR and then write the number of the desired Logical Device to the EFDR. If accessing the Chip (Global) Control Registers, this step is not required. Secondly, write the address of the desired configuration register within the Logical Device to the EFIR and then write (or read) the desired configuration register through the EFDR.

#### **3. Exit the extended function mode**

To exit the Extended Function Mode, writing 0xAA to the EFER is required. Once the chip exits the Extended Function Mode, it is in the normal running mode and is ready to enter the configuration mode.

### Example Program

Enable watchdog timer and set 30 sec. as timeout interval

```
;----- Enter to extended function mode -----  
Mov    dx,    2eh  
Mov    al,    87h  
Out    dx,    al  
Out    dx,    al  
;----- Select Logical Device 8 of watchdog timer -----  
Mov    al,    07h  
Out    dx,    al  
Inc    dx  
Mov    al,    08h  
Out    dx,    al  
;----- Set second as counting unit -----  
Dec    dx  
Mov    al,    0f5h  
Out    dx,    al  
Inc    dx  
In     al,    dx  
And    al,    not 08h  
Out    dx,    al  
;----- Set timeout interval as 30seconds and start counting -----  
Dec    dx  
Mov    al,    0f6h  
Out    dx,    al  
Inc    dx  
Mov    al,    30  
Out    dx,    al  
;----- Exit the extended function mode -----  
Dec    dx  
Mov    al,    0aah  
Out    dx,    al
```

## Flash BIOS Update

### I. Before System BIOS update

1. Prepare a bootable media (ex. USB storage device) which can boot system to DOS prompt.
2. Download and save the BIOS file (ex. 58720P01.bin) to the bootable device.
3. Copy AMI flash utility – AFUDOS.exe into bootable device.

```
C:\>dir

Volume in drive C is PROTECH
Volume Serial Number is 3CCE-a150
Directory of C:\

                <DIR>                12-14-12    5.50P
                <DIR>                12-14-12    5.50P
AFUDOS   EXE           159,008    03-04-10    4.16p
README  TXT              2,684    03-04-10    2.33p
AFUDOS  TXT              2,906    03-04-10    3.02p
620x0Pxx BIN           8,388,608  07-19-13    2.20p
         4 file(d)                   8,553,206 bytes
         2 dir(s)                   787,197,952 bytes free

C:\>
```

4. Make sure the target system can first boot to the bootable device.
  - a. Make sure the target system can first boot to the bootable device. Connect the bootable USB device.
  - b. Turn on the computer and press <F2> or <Del> key during boot to enter BIOS Setup.
  - c. System will go into the BIOS setup menu.

- d. Select [Boot] menu.
- e. Select [Hard Drive BBS Priorities], set the USB bootable device to be the 1<sup>st</sup> boot device.
- f. Press <F4> key to save configuration and exit the BIOS setup menu.

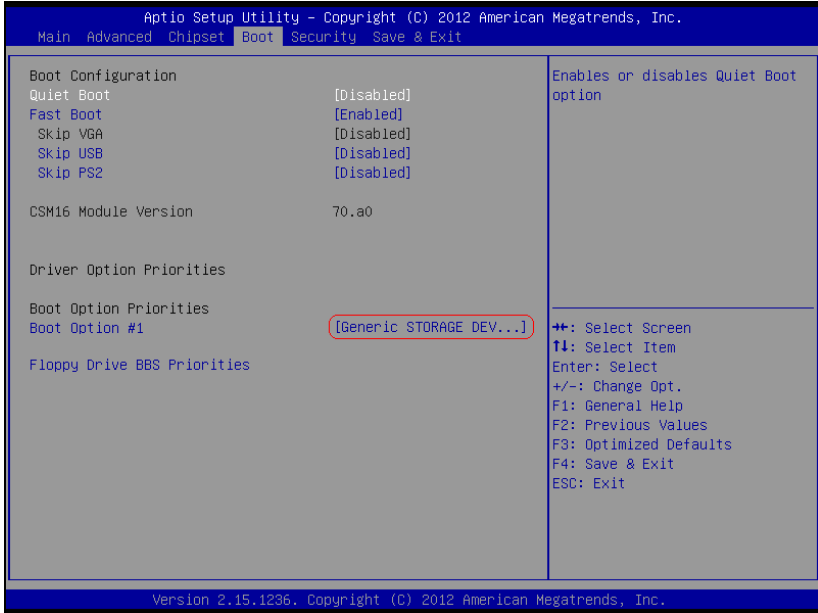

## II. AFUDOS Command for System BIOS Update

AFUDOS.exe is the AMI firmware update utility; the command line is shown as below:

AFUDOS <ROM File Name> [option1] [option2]...

You can type **AFUDOS /?** to see all the definition of each control options. The recommended options for BIOS ROM update consist of following parameters:

**/P:** program main BIOS image

**/B:** program Boot Block

**/N:** program NVRAM

**/X:** don't check ROM ID

### III. BIOS update procedure

1. Use the bootable USB device to boot up system into the MS-DOS command prompt.
2. Type in [AFUDOS 5872xxxx.bin/p/b/n/x](#) and press enter to start the flash procedure.

**Note:** “xxxx” means the BIOS revision part, i.e. 0P01...

3. During the update procedure, you will see the BIOS update process status and its percentage. Beware! Do not turn off system power or reset your computer if the whole procedure are not complete yet, or it may crash the BIOS ROM and make system unable to boot up next time.
4. After BIOS update procedures is complete, the messages should be like the figure shown below:

```
C:\>afudos 58720P01.BIN /P /B /N /X
+-----+
|          AMI Firmware Update Utility(APTIO)          v2.35          |
| Copyright (C) 2010 American Megatrends Inc. All Rights Reserved. |
+-----+
Reading file ..... done
FFS checksums ..... ok
Erasing flash ..... done
Writing flash ..... done
Verifying flash ..... done
Erasing NVRAM ..... done
Writing NVRAM ..... done
Verifying NVRAM ..... done
Erasing BootBlock .... done
Writing BootBlock .... done
Verifying BootBlock ... done

C:\>_
```

5. You can restart the system and boot up with new BIOS now.
6. Update is complete after restart.
7. Verify during following boot that the BIOS version displayed at initialization screen has changed.

