

USER MANUAL

PA-3222

10.1" POS Terminal

Powered by Intel® Celeron®

J1900 Quad-Core

PA-3222 M1

PA-3222 POS System

With SATA/ 3COM/5USB

COPYRIGHT NOTICE & TRADEMARK

All trademarks and registered trademarks mentioned herein are the property of their respective owners.

This manual is copyrighted in May 2017. You may not reproduce or transmit in any form or by any means, electronic, or mechanical, including photocopying and recording.

DISCLAIMER

This user's manual is meant to assist users in installing and setting up the system. The information contained in this document is subject to change without any notice.

CE NOTICE

This is a class A product. In a domestic environment this product may cause radio interference in which case the user may be required to take adequate measures.

FCC NOTICE

This equipment has been tested and found to comply with the limits for a Class A digital device, pursuant to part 15 of the FCC Rules. These limits are designed to provide reasonable protection against harmful interference when the equipment is operated in a commercial environment. This equipment generates, uses, and can radiate radio frequency energy and, if not installed and used in accordance with the instruction manual, may cause harmful interference to radio communications. Operation of this equipment in a residential area is likely to cause harmful interference in which case the user will be required to correct the interference at his own expense.

You are cautioned that any change or modifications to the equipment not expressly approve by the party responsible for compliance could void your authority to operate such equipment.

	<p>CAUTION: Danger of explosion may occur when the battery is incorrectly replaced. Replace the battery only with the same or equivalent type recommended by the manufacturer. Dispose of used batteries according to the manufacturer's instructions.</p>
------------------------------------------------------------------------------------	-------------------------------------------------------------------------------------------------------------------------------------------------------------------------------------------------------------------------------------------------------------------

	<p>WARNING: Some internal parts of the system may have high electrical voltage. We strongly recommend that only qualified engineers are allowed to service and disassemble the system. If any damages should occur on the system and are caused by unauthorized servicing, it will not be covered by the product warranty. Please operate the LCD and Touchscreen with extra care as they can break easily.</p>
-------------------------------------------------------------------------------------	------------------------------------------------------------------------------------------------------------------------------------------------------------------------------------------------------------------------------------------------------------------------------------------------------------------------------------------------------------------------------------------------------------------------

Contents

Revision History	ix
1 Introduction	1-1
1.1 About This Manual	1-2
2 Getting Started	2-1
2.1 Package List.....	2-2
2.2 System Views Without i-Button and Fingerprint Modules	2-3
2.2.1 Front View	2-3
2.2.2 Rear View	2-3
2.2.3 Top View	2-4
2.2.4 Bottom View	2-5
2.2.5 Quarter View.....	2-5
2.2.6 Side View.....	2-6
2.3 System Views With i-Button Module	2-7
2.3.1 Front View	2-7
2.3.2 Rear View	2-7
2.3.3 Top View	2-8
2.3.4 Bottom View	2-9
2.3.5 Quarter View.....	2-9
2.3.6 Side View.....	2-10
2.4 System Views With Fingerprint Module	2-11
2.4.1 Front View	2-11
2.4.2 Rear View	2-11
2.4.3 Top View	2-12
2.4.4 Bottom View	2-13
2.4.5 Side View.....	2-13

2.5	System Specifications	2-14
2.6	Safety Precautions	2-16
3	System Configuration.....	3-1
3.1	External System I/O Ports Diagram & Pin Assignment.....	3-2
3.1.1	Rear I/O Ports Diagram	3-2
3.2	Jumper & Connector Quick Reference Table.....	3-3
3.3	Component Locations Of System Main Board.....	3-4
3.3.1	Top View of System Main Board	3-4
3.4	How To Set Jumpers	3-6
3.5	Function Buttons and I/O Ports	3-8
3.5.1	Power Button	3-8
3.5.2	DC_IN Port (DC_IN).....	3-8
3.5.3	VGA Port (VGA).....	3-8
3.5.4	COM Ports (COM1, COM2, COM3)	3-9
3.5.5	USB Ports (USB0, USB1, USB2, USB3, USB5)	3-10
3.5.6	LAN Port (LAN).....	3-10
3.5.7	Cash Drawer Port (DRW1).....	3-11
3.6	Setting Main Board Connectors and Jumpers	3-12
3.6.1	COM, Cash Drawer Port Voltage Selection (JP_COM2, JP_COM3).....	3-12
3.6.2	COM Connectors (COM1_1, COM2_1, COM3_1, COM4_1)	3-13
3.6.3	i-Button Connector (I-BUT).....	3-13
3.6.4	COM2 & i-Button Function Selection (JP10, JP11, JP12)	3-13
3.6.5	Cash Drawer Control Selection (JP15)	3-14

3.6.6	USB Connectors (USB6, USB7)	3-18
3.6.7	LED Connector (LED1)	3-19
3.6.8	Speaker Connector (SPK1_1)	3-19
3.6.9	Power Connectors (DC12V, DC24V)	3-20
3.6.10	Inverter Connector (INV1)	3-21
3.6.11	Reserved Connectors (SPK2_1, GPIO1)	3-21
3.6.12	Panel Resolution Selection (JP5, JP6).....	3-22
3.6.13	Mini PCIE USB Selection (JP13).....	3-22
3.6.14	MSR / Card Reader Connector (PS2)	3-23
3.6.15	LVDS Connector (LVDS1)	3-24
3.6.16	Touch Panel Signal Interface Selection (JP8, JP9).....	3-25
3.6.17	SATA & SATA Power Connector (SATA1, SATA2, SATA_PWR1, SATA_PWR2).....	3-26
3.6.18	BIOS Update Selection (JP1).....	3-27
3.6.19	Clear CMOS Data Selection (JP2)	3-27
3.6.20	LVDS Link (JP16)	3-28
3.6.21	LVDS Voltage Selection (JP17)	3-28
3.6.22	Panel Enable Selection (JP20).....	3-29
3.6.23	Mini-PCle Connector (M_PCI_E1)	3-29
3.7	Printer Board Component Locations & Pin Assignment	3-30
3.7.1	Printer Board: PDAC-3100	3-30
3.7.2	Jumper & Connector Quick Reference Table	3-31
3.7.3	Setting Printer Board Connectors and Jumpers: PDAC-3100	3-32
3.7.3.1	Power Supply Connector	3-32
3.7.3.2	RS-232 Interface Connector	3-32
3.7.3.3	Auto-Cutter Connector	3-33
3.7.3.4	USB Connector	3-33
3.7.3.5	Thermal Head/Motor/Sensor Connector	3-34
3.7.3.6	Terminal Assignment Connector	3-36

3.7.4	Printer Board: MB-1030 series	3-37
3.7.4.1	Jumper & Connector Quick Reference Table.....	3-38
3.7.5	Setting Printer Board Connectors and Jumpers.....	3-39
3.7.5.1	Power Supply Connector	3-39
3.7.5.2	RS-232 Interface Connector	3-39
3.7.5.3	Thermal Head/Motor/Sensor Connector	3-40
3.7.5.4	Auto-Cutter Connector	3-42
3.7.5.5	Paper-Near-END Sensor Connector.....	3-42
3.7.5.6	USB Interface Connector	3-43
3.7.5.7	Terminal Assignment Connector	3-43
3.7.6	Printer Board: MB-1011 & MB-1013.....	3-44
3.7.6.1	Jumper & Connector Quick Reference Table.....	3-45
3.7.7	Setting Printer Board Connectors and Jumpers: MB-1011 & MB-1013.....	3-46
3.7.7.1	Power Supply Connector	3-46
3.7.7.2	RS-232 Interface Connector	3-46
3.7.7.3	Auto-Cutter Connector	3-47
3.7.7.4	Thermal Head/Motor/Sensor Connector	3-47
3.7.7.5	Terminal Assignment Connector	3-49
3.7.7.6	USB Interface Connector	3-49
3.8	VFD Board Component Locations & Pin Assignment.....	3-50
3.8.1	VFD Board: MB-4103, LD720	3-50
3.8.2	Jumper & Connector Quick Reference Table	3-51
3.8.3	Setting MB-4103 & LD720 VFD Board Connectors and Jumpers.....	3-52
3.8.3.1	Power Switch Selection	3-52
3.8.3.2	RS-232 Serial Interface Connector	3-53
3.9	MSR Board Component Locations & Pin Assignment	3-54

3.9.1	ID TECH	3-54
3.9.1.1	Main Connector.....	3-54
3.9.2	MB-3012	3-55
3.9.2.1	Information Button Reader	3-55
3.9.2.2	Output Connector.....	3-55
4	Software Utilities	4-1
4.1	Introduction.....	4-2
4.2	Installing Intel® Chipset Software Installation Utility	4-3
4.2.1	Installing Intel® Chipset Driver	4-3
4.3	Installing VGA Driver Utility	4-4
4.4	Installing LAN Driver Utility.....	4-4
4.5	Installing Sound Driver Utility	4-6
4.6	Installing Fingerprint Driver Utility (Optional)	4-7
4.7	Installing RFID Module Driver Utility (Optional)	4-7
4.8	Installing Wireless Module Driver Utility (Optional)	4-8
4.9	Peripheral Devices	4-9
4.9.1	Printer Board: MB-1030.....	4-9
4.9.1.1	Commands List	4-9
4.9.1.2	OPOS Printer Driver.....	4-55
4.9.2	VFD: MB-4103 (RS-232)	4-63
4.9.2.1	Commands List	4-63
4.9.2.2	OPOS Driver	4-64
4.9.3	MSR: MB-3102 (PS/2).....	4-69
4.9.3.1	OPOS Driver	4-69
4.9.4	MSR: GIGA-TMS MJR243 (RS-232).....	4-75
4.9.4.1	Commands List	4-75

4.9.4.2	OPOS MSR Register	4-77
4.9.4.3	OPOS MSR Tester	4-85
4.10	API.....	4-89
4.10.1	API Package Content	4-89
4.10.2	API Procedure	4-90
4.10.3	Cash Drawer.....	4-93
4.10.4	Watchdog.....	4-94
4.11	API Function.....	4-95
4.11.1	Cash Drawer Function.....	4-95
4.11.2	Watch Dog Function	4-96
5	BIOS SETUP	5-1
5.1	Introduction.....	5-2
5.2	Accessing Setup Utility.....	5-3
5.3	Main.....	5-7
5.4	Advanced	5-9
5.4.1	Advanced – ACPI Settings	5-10
5.4.2	Advanced – F81866 Super IO Configuration	5-11
5.4.3	Advanced – Hardware Monitor	5-17
5.4.4	Advanced – F81866 Watchdog Configuration.....	5-18
5.4.5	Advanced – CPU Configuration	5-19
5.4.6	Advanced – CPU Configuration > Socket 0 CPU Information	5-20
5.4.7	Advanced – IDE Configuration (AHCI Mode).....	5-22
5.4.8	Advanced – OS Selection	5-24
5.4.9	Advanced – CSM Configuration	5-25
5.4.10	Advanced – USB Configuration.....	5-27

5.5	Chipset	5-28
5.5.1	North Bridge	5-29
5.5.1.1	North Bridge – LCD Control	5-30
5.5.2	South Bridge.....	5-31
5.6	Security	5-32
5.7	Boot	5-33
5.7.1	Boot – Hard Drive BBS Priorities.....	5-34
5.8	Save & Exit.....	5-35
 Appendix A System Diagrams		A-1
	Exploded Diagram For System Top Case	A-2
	System Exploded Diagram	A-3
	Exploded Diagrams For System LCD Panel	A-5
	Exploded Diagrams For System LCD Panel	A-6
	Exploded Diagrams For System LCD Panel	A-7
	Exploded Diagram For HDD.....	A-8
	Exploded Diagram For MSR Module.....	A-9
	Exploded Diagram For Fingerprint Module	A-10
	Exploded Diagram For 3-Inch Printer (1)	A-11
	Exploded Diagram For 3-Inch Printer (2)	A-12
	Exploded Diagram For 2-Inch Printer (1)	A-13
	Exploded Diagram For 2-Inch Printer (2)	A-14
	Exploded Diagram For VFD Module	A-16
 Appendix B Technical Summary		B-1
	Interrupt Map	B-2
	DMA MAP	B-5
	I/O Map	B-6
	Memory Map.....	B-8

Configuring WatchDog Timer	B-10
Flash BIOS Update.....	B-13

Revision History

The revision history of PA-3222 User Manual is described below:

Version No.	Revision History	Page No.	Date
M1	Initial Release	-	2017/05/10

1

Introduction

This chapter provides the introduction for the PA-3222 system as well as the framework of the user manual.

The following topic is included:

- About This Manual

1.1 About This Manual

Thank you for purchasing our PA-3222 system. The PA-3222 is an updated system designed to be comparable with the highest performance of IBM AT personal computers. The PA-3222 provides faster processing speed, greater expandability and can handle more tasks than before. This manual is designed to assist you how to install and set up the whole system. It contains 5 chapters and 2 appendixes. Users can configure the system according to their own needs. This user manual is intended for service personnel with strong hardware background. It is not intended for general users.

The following section describes the structure of this user manual.

Chapter 1 Introduction

This chapter introduces the framework of this user manual.

Chapter 2 Getting Started

This chapter describes the package contents and system specifications, and illustrates the physical appearances for the PA-3222 system. Read the safety reminders carefully on how to take care of your system properly.

Chapter 3 System Configuration

This chapter describes the locations and functions of the system motherboard components. You will learn how to properly configure the connectors and system configuration jumpers on the motherboard and configure the system to meet your own needs.

Chapter 4 Software Utilities

This chapter introduces how to install Intel Chipset Software Installation Utility, Intel Management Engine Components Installer Driver Utility, Intel USB 3.0 Extensible Host Controller Driver Utility, Graphics Driver Utility, LAN Driver Utility and Sound Driver Utility.

Chapter 5 AMI BIOS Setup

This chapter provides BIOS setup information.

Appendix A System Assembly Diagrams

This appendix provides the exploded diagrams and part numbers of the PA-3222.

Appendix B Technical Summary

This appendix provides the information about the allocation maps for system resources, Watchdog Timer Configuration and Flash BIOS Update.

2 Getting Started

This chapter provides the information for the PA-3222 system. It describes how to set up the system quickly and outlines the system specifications.

The following topics are included:

- Package List
- System Overview
- System Diagrams
- System Specification
- Safety Precautions

Experienced users can go to Chapter 3 System Configuration on page 3-1 for a quick start.

2.1 Package List

If you discover any of the items listed below are damaged or list, please contact your local distributor immediately.

Item	Q'ty
PA-3222	1
Manual / Driver DVD	1
Quick Reference Guide	1
AC Power Cord (Optional)	1
MSR Card Reader (Optional)	1
i-Button + MSR Card Reader (Optional)	1
Wireless LAN (IEEE 802.11 b+g) (Optional)	1
VFD (Optional)	1

2.2 System Views Without i-Button and Fingerprint Modules

2.2.1 Front View

Unit: mm

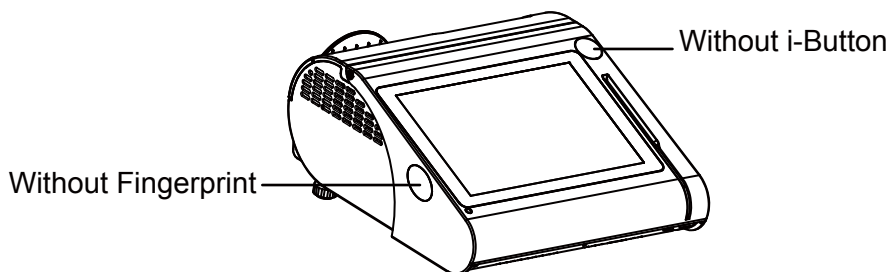

2.2.2 Rear View

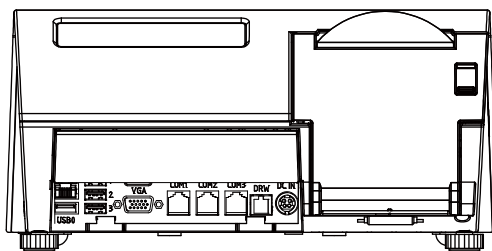

2.2.3 Top View

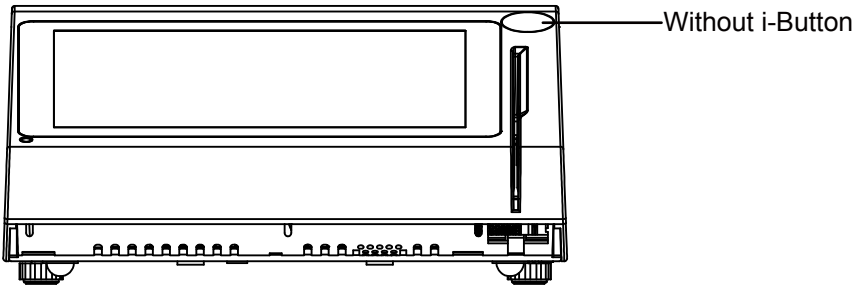
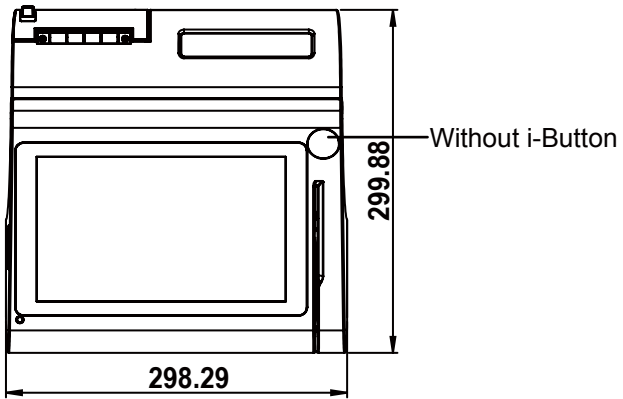

2.2.4 Bottom View

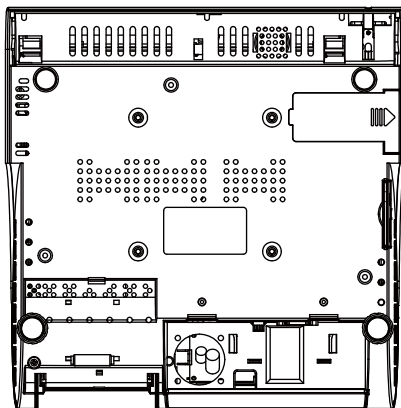

2.2.5 Quarter View

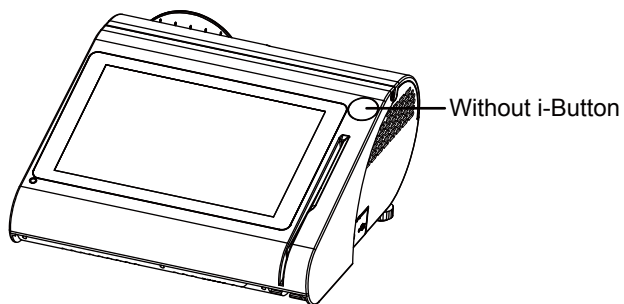

2.2.6 Side View

Unit: mm

Without Fingerprint module

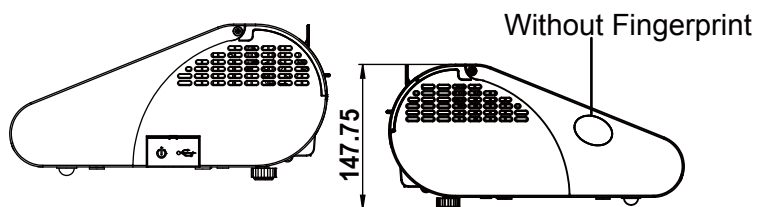

2.3 System Views With i-Button Module

2.3.1 Front View

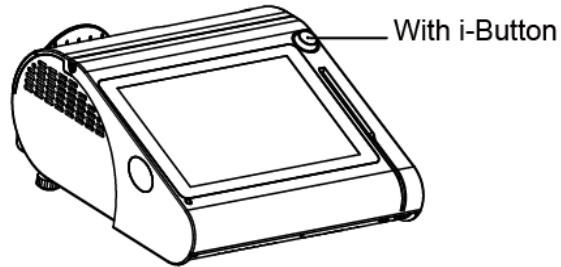

2.3.2 Rear View

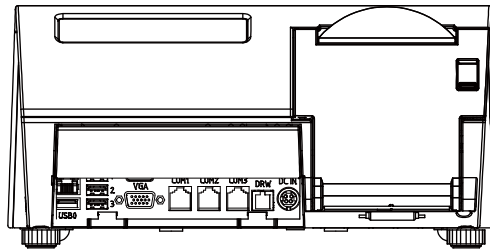

2.3.3 Top View

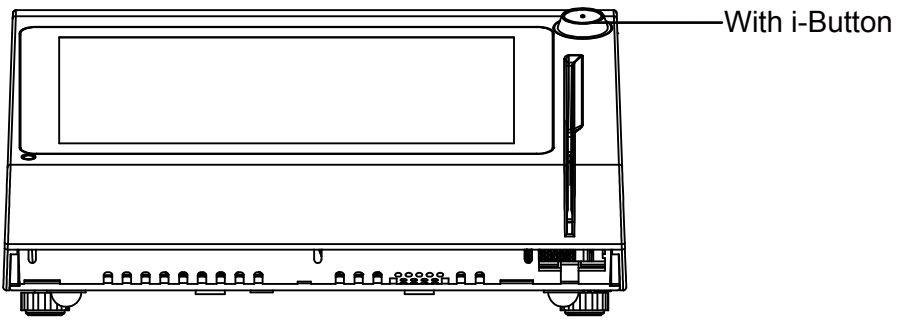
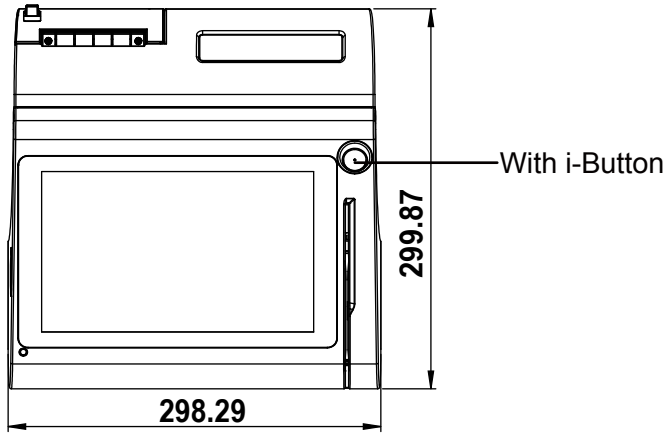

2.3.4 Bottom View

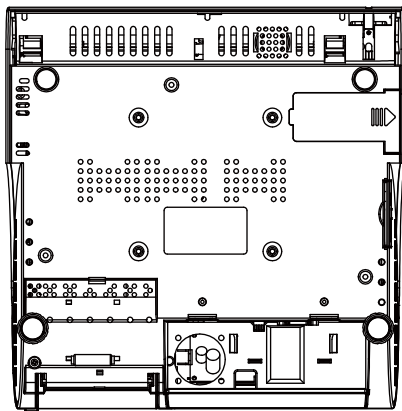

2.3.5 Quarter View

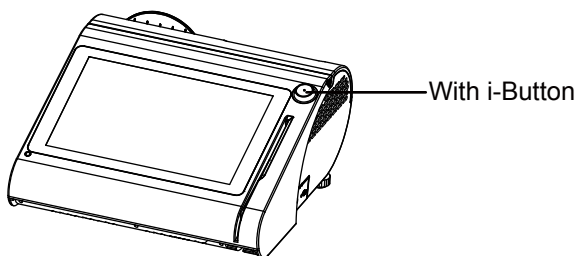

2.3.6 Side View

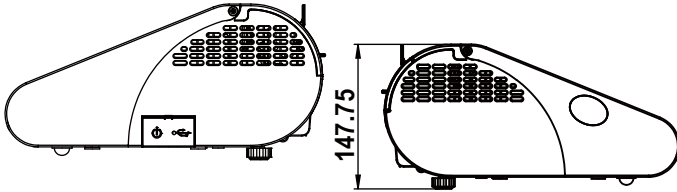

2.4 System Views With Fingerprint Module

2.4.1 Front View

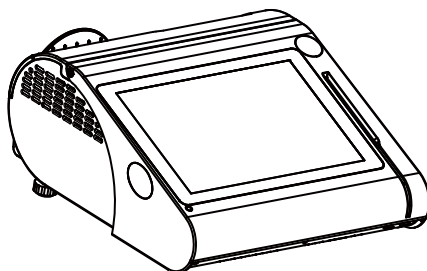

2.4.2 Rear View

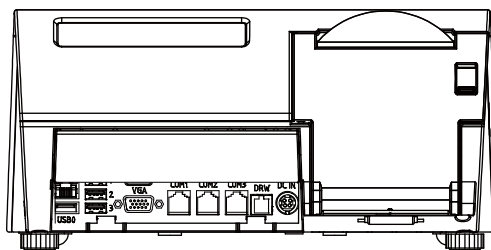

2.4.3 Top View

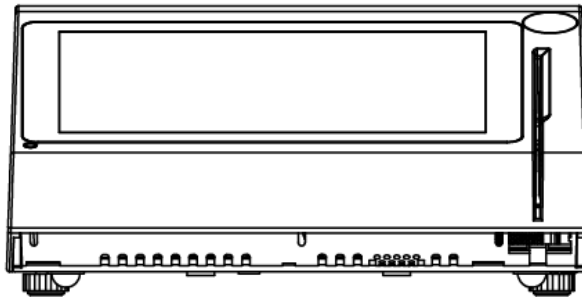
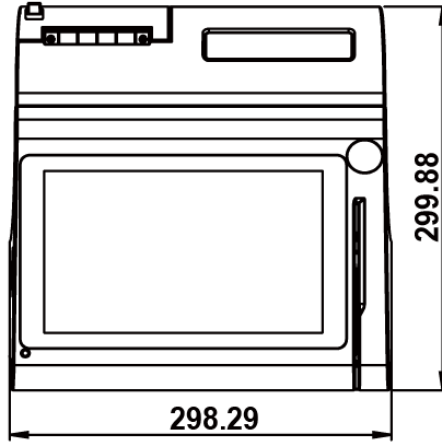

2.4.4 Bottom View

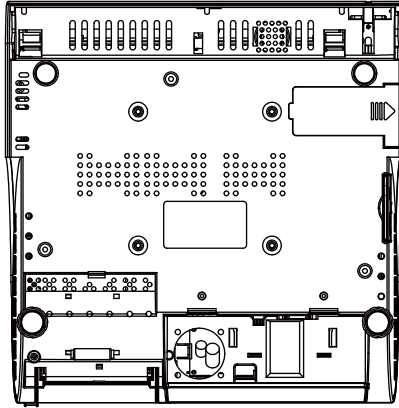

2.4.5 Side View

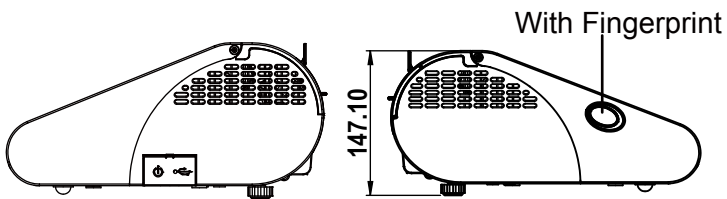

2.5 System Specifications

System	
CPU Support	➤ Intel® Celeron® J1900 CPU
Memory	➤ 1 x DDR3L SO-DIMM Slot (up to 8GB)
Network	➤ 10/100/1000Mbps Base-T Fast Ethernet
Power Supply	➤ 60~90 Watt power adapter
Audio	➤ 2W speaker
System Weight	➤ with power adaptor approx. 4kg
Dimension (W x H x D)	➤ 300mm x 299mm x 135mm
O.S. Support	➤ Win10 / Win8.1 / POSReady7 / Andriod4.4
Storage	
SATA	➤ 1 x 2.5" HDD or SSD
I/O Ports	
USB	➤ 3 x USB 2.0 and 1 x USB 3.0 on rear ➤ 1 x USB 2.0 on side bezel
Serial Ports	➤ 3 x RJ45 (all support +5V/12V selectable)+ 1 (optional) x DB9
LAN	➤ 1 x RJ45
VGA	➤ 1x DB15
Cash Drawer	➤ 1 + 1 (option, with Y cable) x RJ11 (+12V or +24V selectable)
DC IN	➤ 1 x 4-pin DC Power Jack
Peripheral	
Customer Display	➤ VFD, 20 columns and 2 lines, each column is 5 x 7 dots
Printer	➤ 2" or 3" easy loading thermal printer with Auto cutter
MSR & i-Button	➤ JIS-I or II, ISO Track1+2+3 (PS/2 interface)
Fingerprint	➤ 8-bit grayscale, reader
Display	
LCD	➤ 10.1" TFT LCD
Resolution	➤ 1280 x 800
Brightness	➤ 400 cd/m ²
Touch Screen	➤ 10.1" Capacitive Touch panel, USB interface (EETI controller)
Tilt Angle	➤ 24 ~ 30 degree

Environment

EMC & Safety	➤ CE / FCC
Operating Temp.	➤ 0°C ~ 35°C (32°F ~ 95°F)
Storage Temp.	➤ -5°C ~ 60°C (23°F ~ 140°F)
Humidity	➤ 20% ~ 90%

2.6 Safety Precautions

Before operating this system, read the following information carefully to protect your systems from damages, and extend the life cycle of the system.

1. Check the Line Voltage
 - The operating voltage for the power supply should be within the range of 100V to 240V AC; otherwise the system may be damaged.
2. Environmental Conditions
 - Place your PA-3222 on a sturdy, level surface. Be sure to allow enough space around the system to have easy access needs.
 - Avoid installing your PA-3222 system in extremely hot or cold places.
 - Avoid direct sunlight exposure for a long period of time (for example, in a closed car in summer time. Also avoid the system from any heating device.). Or do not use PA-3222 when it has been left outdoors in a cold winter day.
 - Avoid moving the system rapidly from a hot place to a cold place, and vice versa, because condensation may occur inside the system.
 - Protect your PA-3222 from strong vibrations which may cause hard disk failure.
 - Do not place the system too close to any radio-active device. Radio-active device may cause signal interference.
 - Always shut down the operating system before turning off the power.
3. Handling
 - Avoid placing heavy objects on the top of the system.
 - Do not turn the system upside down. This may cause the hard drive to malfunction.
 - Do not allow any objects to fall into this device.
 - If water or other liquid spills into the device, unplug the power cord immediately.
4. Good Care
 - When the outside case gets stained, remove the stains using neutral washing agent with a dry cloth.
 - Never use strong agents such as benzene and thinner to clean the surface of the case.
 - If heavy stains are present, moisten a cloth with diluted neutral washing agent or alcohol and then wipe thoroughly with a dry cloth.
 - If dust is accumulated on the case surface, remove it by using a special vacuum cleaner for computers.

3 System Configuration

This chapter contains helpful information that describes the jumper and connector settings, component locations, and pin assignment.

The following topics are included:

- System External I/O Ports Diagram
- Function Buttons and I/O Ports
- Main Board Component Locations & Jumper Settings
- Setting Jumpers
- Setting Main Board Connectors and Jumpers
- Printer Board Component Locations & Pin Assignment
- Setting Printer Board Connectors and Jumpers
 - PDAC-3100
 - MB-1030 series
 - MB-1011 & MB-1013
- Setting VFD Board Connectors and Jumpers
- Setting MSR

3.1 External System I/O Ports Diagram & Pin Assignment

3.1.1 Rear I/O Ports Diagram

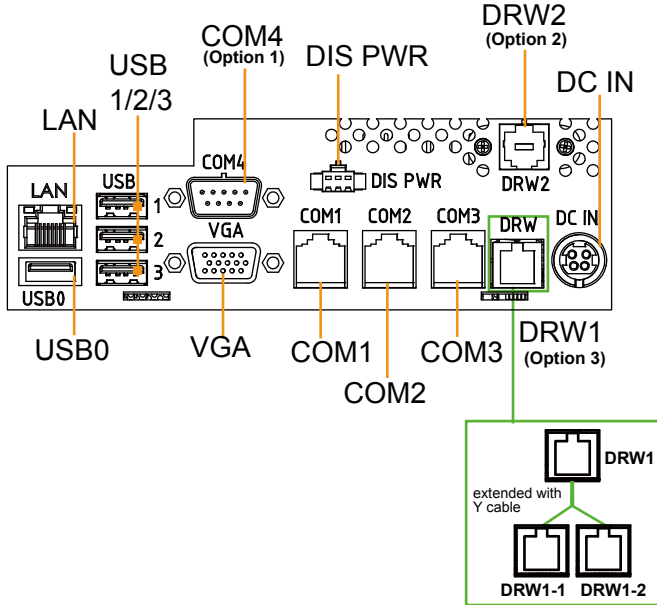

Side I/O

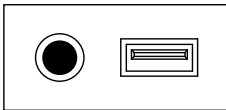

Power Button USB5

3.2 Jumper & Connector Quick Reference Table

JUMPER Description	NAME
COM2/COM3 Port Pin9 Voltage Selection	JP_COM2, JP_COM3
BIOS Update Selection	JP1
Clear CMOS Data Selection	JP2
Panel Resolution Selection	JP5, JP6
Touch Panel Signal Interface Selection	JP8, JP9
COM2, i-Button Function Selection	JP10, JP11, JP12
Mini PCIE USB Selection	JP13
Cash Drawer Control Selection	JP15
LVDS Link	JP16
LVDS Voltage Selection	JP17
Panel Enable Selection	JP20

System CONNECTOR Description	NAME
COM Ports and Cash Drawer Port	COM2, COM3, COM1, COM4, DRW1
COM Connectors	COM1_1, COM2_1, COM3_1, COM4_1
i-Button Connector	I-BUT
Cash Drawer Ports	DRW1 (DRW1-1, DRW1-2), DRW2
USB Ports / Connectors	USB0-3, USB5, USB6, USB7
LED Connector	LED1
Speaker Connector	SPK1_1
Power Connector	DC12V, DC24V
Inverter Connector	INV1
Reserved Connectors	SPK2_1, GPIO1
MSR / Card Reader Connector	PS2
LVDS Connector	LVDS1
SATA & SATA Power Connectors	SATA1, SATA2, SATA_PWR1, SATA_PWR2
Mini-PCIE Connector	M_PCI_E1

3.3 Component Locations Of System Main Board

3.3.1 Top View of System Main Board

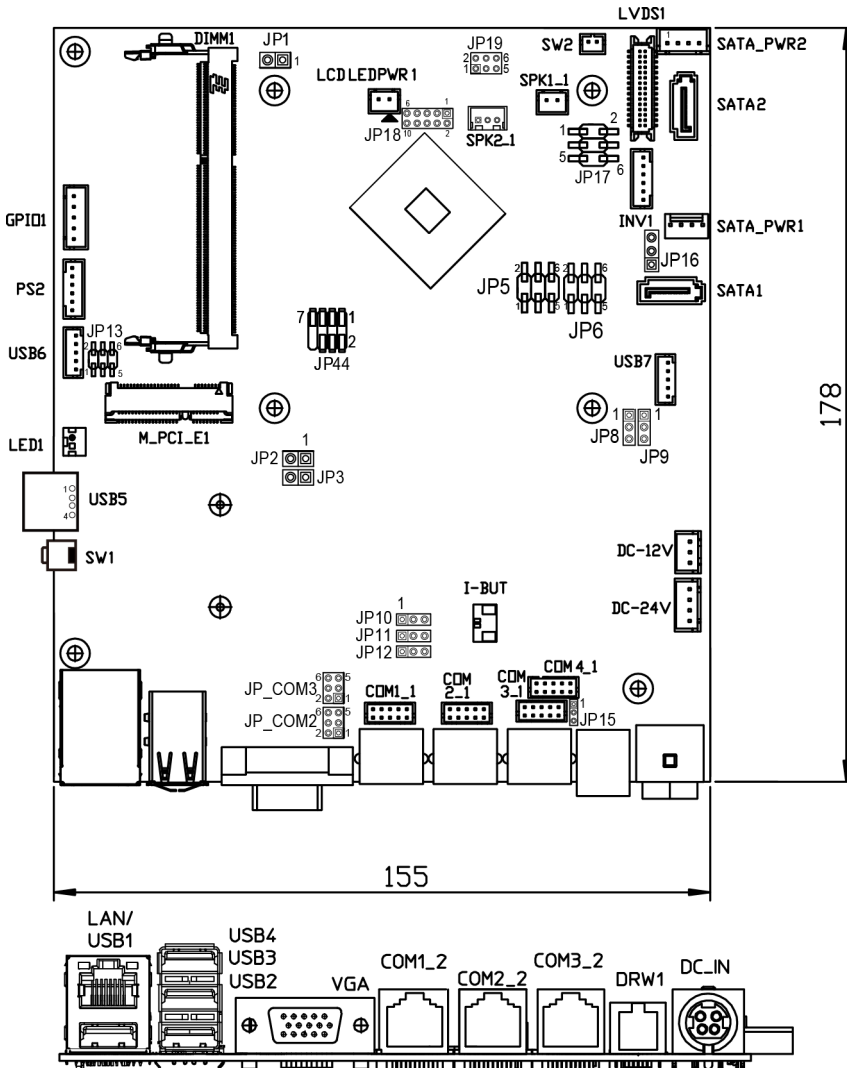





Figure 3-1. Main Board Component Location (Top View)

	<p>WARNING: Always disconnect the power cord when you are working with connectors and jumpers on the main board. Make sure both the system and peripheral devices are turned OFF as sudden surge of power could damage sensitive components. Make sure PA-3222 is properly grounded.</p>
	<p>CAUTION: Observe precautions while handling electrostatic sensitive components. Make sure to ground yourself to prevent static charge while you are working on the connectors and jumpers. Use a grounding wrist strap and place all electronic components in any static-shielded devices.</p>
	<p>CAUTION: Always touch the motherboard components by the edges. Never touch components such as a processor by its pins. Take special cares while you are holding electronic circuit boards by the edges only. Do not touch the mainboard components.</p>

3.4 How To Set Jumpers

You can configure your board by setting the jumpers. A jumper consists of two or three metal pins with a plastic base mounted on the card. By using a small plastic "cap", also known as the jumper cap (with a metal contact inside), you are able to connect the pins. So you can configure your hardware settings by "opening" or "closing" jumpers.

Jumpers can be combined into sets that are called jumper blocks. When jumpers are all in the block, you have to put them together to set up the hardware configuration. The figure below shows what this looks like.

Jumpers & Caps

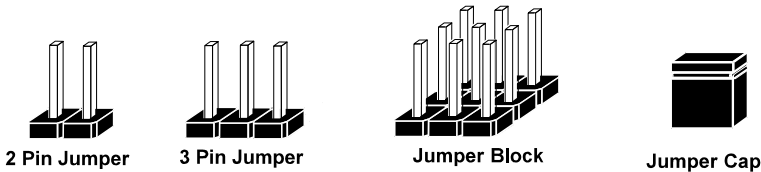

If a jumper has three pins, for example, labeled 1, 2 and 3. You can connect pins 1 and 2 to create one setting and shorting. You can also select to connect pins 2 and 3 to create another setting. The format of the jumper picture will be illustrated throughout this manual. The figure below shows different types of jumpers and jumper settings.

Jumper diagrams



Jumper Cap looks like this

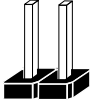

2 pin Jumper looks like this

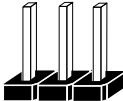

3 pin Jumper looks like this

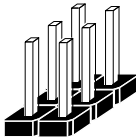

Jumper Block looks like this

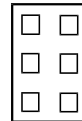

Jumper settings



1

2 pin Jumper closed(enabled)
looks like this



1

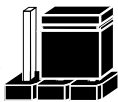

1

3 pin Jumper
2-3 pin closed(enabled)
looks like this



1

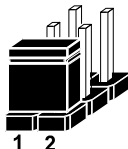

1 2

Jumper Block
1-2 pin closed(enabled)
looks like this

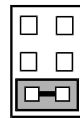

1 2

3.5 Function Buttons and I/O Ports

3.5.1 Power Button

To turn on the system, press the power button on the side of the system briefly.

ACTION	ASSIGNMENT
Press	0V
Release	+3.3V



Power Button

3.5.2 DC_IN Port (DC_IN)

Port Name: DC_IN

Description: DC Power-In Port (rear I/O)

PIN	ASSIGNMENT	PIN	ASSIGNMENT
1	GND	3	+24V
2	GND	4	+24V

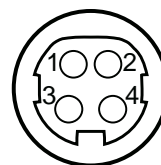

DC_IN

3.5.3 VGA Port (VGA)

Port Name: VGA

Description: VGA Port, D-Sub 15-pin (rear I/O)

PIN	ASSIGNMENT	PIN	ASSIGNMENT
1	RED	9	+5V
2	GREEN	10	GND
3	BLUE	11	NC
4	NC	12	DDCA DATA
5	GND	13	HSYNC
6	GND	14	VSYNC
7	GND	15	DDCA CLK
8	GND	-	-

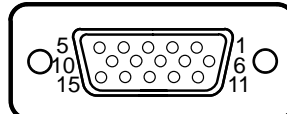

VGA

3.5.4 COM Ports (COM1, COM2, COM3)

Port Name: COM1, COM2, COM3

Description: COM Ports (rear IO)

PIN	ASSIGNMENT	PIN	ASSIGNMENT
1	DCD1/2/3	6	DSR1/2/3
2	RXD1/2/3	7	RTS1/2/3
3	TXD1/2/3	8	CTS1/2/3
4	DTR1/2/3	9	RI/+5V/+12V selectable (Max. current: 1A)
5	GND	-	-

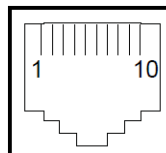

**COM1/
COM2/
COM3**

Note: COM2 & COM2_1 will not function when jumpers JP10, JP11, JP12 are set as 2-3 connected (i-Button). Refer to the **i-Button Function Selection** section for details. COM4 will not function when COM4_1 is selected as the printer control interface.

Port Name: COM4 (optional)

Description: D-Sub9 Serial Port (rear I/O),
Co-lay with COM4_1

PIN	ASSIGNMENT	PIN	ASSIGNMENT
1	DCD	6	DSR
2	RXD	7	RTS
3	TXD	8	CTS
4	DTR	9	RI/+5V/+12V selectable (Max. current: 1A)
5	GND	-	-

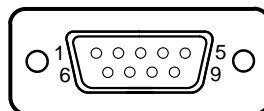

**COM4
(optional)**

3.5.5 USB Ports (USB0, USB1, USB2, USB3, USB5)

Port Name: USB0, USB1, USB2, USB3, USB5

Description: USB Type A Ports

- USB0-3: Rear I/O
- USB5: Side I/O

PIN	ASSIGNMENT
1	+5V (Max. current: 0.5A)
2	D-
3	D+
4	GND



**USB0/
USB1/
USB2/
USB3/
USB5**

Note: The USB0 port is provided with Standby power 5V.
The other USB ports are without standby power.

3.5.6 LAN Port (LAN)

Port Name: LAN

Description: LAN RJ-45 Port (rear IO)

PIN	ASSIGNMENT	PIN	ASSIGNMENT
1	MDIP0	5	MDIP2
2	MDIN0	6	MDIN2
3	MDIP1	7	MDIP3
4	MDIN1	8	MDIN3

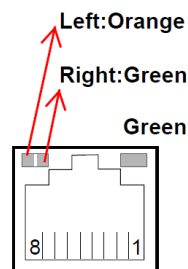

LAN

LAN LED Status

There are LAN LED indicators for LAN on the rear panel of the system. By observing their status, you can know the status of the Ethernet connection.

RB Ver.

LAN LED Indicator	Color	Status	Description
Left Side LED	Orange	Blink	Giga LAN connection is activated.
	Green	Blink	10/100Mbps LAN connection is activated.
Right Side LED	Green	On	LAN switch/hub connected.

3.5.7 Cash Drawer Port (DRW1)

Port Name: DRW1

Description: DRW1 is used by default.

PIN	ASSIGNMENT
1	DRW2 Sense
2	GPIO1 / DRW1
3	Draw1 Sense
4	12V/24V (Max. current: 1A)
5	GPIO2 / DRW2
6	GND

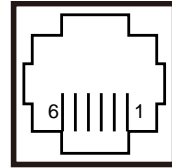

DRW1



3.6 Setting Main Board Connectors and Jumpers

3.6.1 COM, Cash Drawer Port Voltage Selection (JP_COM2, JP_COM3)

Jumper Name: JP_COM2, JP_COM3

Description: COM2, COM3 Port Pin9 RI/5V/12V Selection

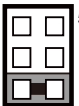
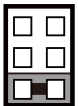
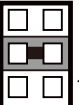
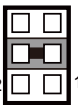
JP_COM2, JP_COM3 Pin headers on board. The voltages of both COM2 & COM3 ports can be adjusted by setting relevant jumpers on board.

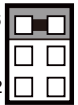
SELECTION	JUMPER SETTING	JUMPER ILLUSTRATION	
RI	1-2 (Default Setting)	 JP_COM2	 JP_COM3
+12V	3-4	 JP_COM2	 JP_COM3
+5V	5-6	 JP_COM2	 JP_COM3

COM1 / COM4 /DRW1

The voltages of the external ports "COM1 & COM4 & Cash Drawer" can be adjusted via BIOS for your convenience.

```

▶ Parallel Port Configuration
  Cash drawer                      [Cash drawer 12V]
  Change Settings                  [Auto]
  COM1 Voltage select              [Disabled]
    
```

3.6.2 COM Connectors (COM1_1, COM2_1, COM3_1, COM4_1)

Connector Name: COM1_1, COM2_1, COM3_1, COM4_1

Description: COM Connectors

PIN	ASSIGNMENT	PIN	ASSIGNMENT
1	DCD	6	DSR
2	RXD	7	RTS
3	TXD	8	CTS
4	DTR	9	RI/+5V/+12V selectable (Max. current: 1A)
5	GND	10	NC

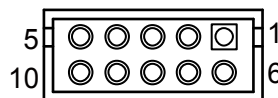

**COM1_1/
COM2_1/
COM3_1/
COM4_1**

3.6.3 i-Button Connector (I-BUT)

Connector Name: I-BUT

Description: i-Button Connector

PIN	ASSIGNMENT
1	COM3_DTR_R_I
2	COM3_RXD_R_I

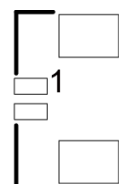



I-BUT

3.6.4 COM2 & i-Button Function Selection (JP10, JP11, JP12)

Jumper Name: JP10, JP11, JP12

Description: i-Button Function Selection

SELECTION	JUMPER SETTING	JUMPER ILLUSTRATION
COM2	1-2 <i>(Default Setting)</i>	 JP10/JP11/JP12/
I-BUT*	2-3	 JP10/JP11/JP12/

*COM2 & COM2_1 will not function when jumpers JP10, JP11 & JP12 are set as "I-BUT".

3.6.5 Cash Drawer Control Selection (JP15)

JP15: DRW1, DRW1-1, DRW1-2

DRW1 port is used by default. You can add a second port via either of the methods below:

Method 1:

DRW1 includes two groups of GPIO pins. The second group is normally unused but can be enabled by the jumper. Set the pin header jumper JP15 as 1-2 connected if necessary.

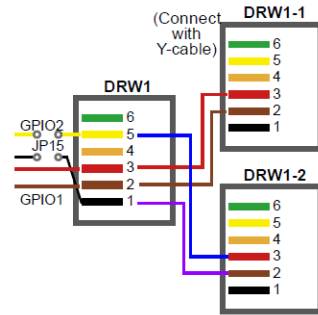

Method 2:

You can split DRW1 into two channels of DRW1-1 & DRW1-2 using the Y-Cable (option).

Jumper Name: JP15

Description: Cash Drawer 2 Selection

SELECTION	JUMPER SETTING	JUMPER ILLUSTRATION
DRW1-1 & DRW1-2	1-2	<p>JP15</p>
DRW1-1 only	2-3	<p>JP15</p>

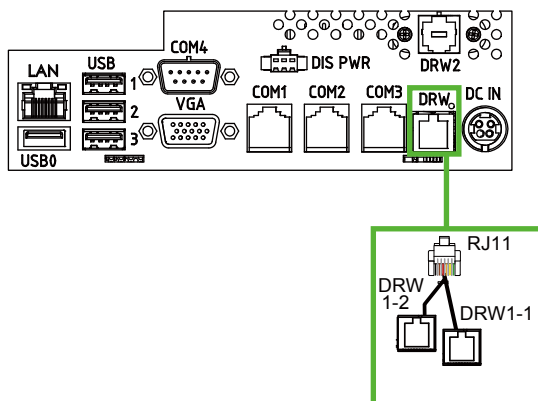

Step 3.

DRW1, DRW1-1, DRW1-2 shares the same power source.
(Default: 12V).

SIO Address	
Cash drawer 1	LDN 06, 0x91 bit 2
Cash drawer 2	LDN 06, 0x91 bit 3

Cash Drawer Configuration

The I/O port address of the cash drawer is 2E (hex) and 2F (hex). 2E (hex) is the address port. 2F (hex) is the data port. User must first assign the address of register by writing address value into address port 2E (hex), then write/read data to/from the assigned register through data port 2F (hex).

Configuration Sequence

To program [F81866](#) configuration registers, the following configuration sequence must be followed:

- (1) Enter the extended function mode
- (2) Configure the configuration registers
- (3) Exit the extended function mode

(1) Enter the extended function mode

To place the chip into the Extended Function Mode, [two successive writes of 0x87](#) must be applied to Extended Function Enable Registers (EFERs, i.e. 2Eh or 4Eh).

(2) Configure the configuration registers

The chip selects the Logical Device and activates the desired Logical Devices through Extended Function Index Register (EFIR) and Extended Function Data Register (EFDR). The EFIR is located at the same address as the EFER, and the EFDR is located at address (EFIR+1). First, write the Logical Device Number (i.e. 0x06) to the EFIR and then write the number of the desired Logical Device to the EFDR. If accessing the Chip (Global) Control Registers, this step is not required. Secondly, write the address of the desired configuration register within the Logical Device to the EFIR and then write (or read) the desired configuration register through the EFDR.

(3) Exit the extended function mode

To exit the Extended Function Mode, [writing 0xAA to the EFER](#) is required. Once the chip exits the Extended Function Mode, it is in the normal running mode and is ready to enter the configuration mode.

Code example for open the cash drawer 1

```
;----- Enter to extended function mode -----  
mov dx, 2eh  
mov al, 87h  
out dx, al  
out dx, al  
;----- Select Logical Device 6 of Cash drawer -----  
mov al, 07h  
out dx, al  
inc dx  
mov al, 06h  
out dx, al  
dec dx  
;----- Open the Cash drawer 1 -----  
mov al, 91h  
out dx, al  
inc dx  
mov al, 04h  
out dx, al  
;----- Exit the extended function mode -----  
dec dx  
mov al, 0aah  
out dx, al
```

Note:

The DRW2 Port can function only when the optional "Printer Kit" is installed on PA-3222. The DRW2 signals from the printer board (MB-1030, MB-1011, MB-1013, PDAC-3100) can be controlled via relevant commands. See the picture below for the location of DRW2 port:

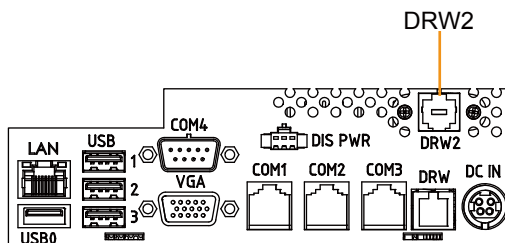

PIN	ASSIGNMENT
1	GND
2	Drawer Open
3	Drawer Sense
4	+24V
5	NC
6	GND

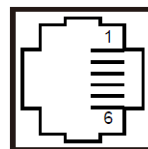

DRW2

Control Codes	Hexadecimal Codes	Function
<DLE EOT>	10 04	Real-time status transmission
<DLE DC4>	10 14	Real-time output of the specified pulse

3.6.6 USB Connectors (USB6, USB7)

Connector Name: USB6, USB7

Description: USB 2.0 connector

PIN	ASSIGNMENT
1	5V (Maximum current: 0.5A)
2	D-
3	D+
4	GND
5	GND

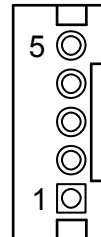

USB6/

USB7

Notes:

1. USB6 signal is shared from the “MINI-PCIE” port.
2. USB6 can function only when JP13 is set as 1-3, 2-4[short].
3. USB7 signal is shared from the “Touch Controller”.
4. USB7 can function only when JP8, JP9 are set as 1-2[short].

3.6.7 LED Connector (LED1)

Connector Name: LED1

Description: Power indication LED connector

PIN	ASSIGNMENT
1	GND
2	PWR_LED

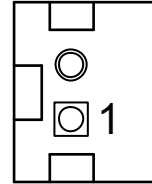

LED1

3.6.8 Speaker Connector (SPK1_1)

Connector Name: SPK1_1

Description: Speaker Connector

PIN	ASSIGNMENT
1	HD_FRONT-OUT-R
2	HD_FRONT-OUT-L

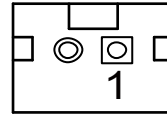

SPK1_1

3.6.9 Power Connectors (DC12V, DC24V)

Connector Name: DC12V

Description: DC 12 Voltage Provider Connector

PIN	ASSIGNMENT
1	VCC12
2	GND
3	VCC12

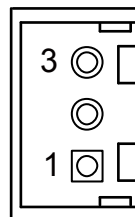

DC12V

Connector Name: DC24V

Description: Power for Thermal Printer Connector

PIN	ASSIGNMENT
1	VCC24
2	VCC24
3	GND
4	GND

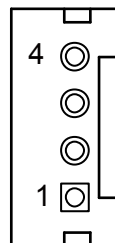

DC24V

3.6.10 Inverter Connector (INV1)

Connector Name: INV1

Description: Inverter connector

PIN	ASSIGNMENT
1	+12V
2	+12V
3	GND
4	BRCTR
5	GND
6	LVDS_BKLTEN

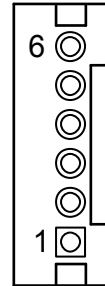

INV1

3.6.11 Reserved Connectors (SPK2_1, GPIO1)

Connector Name: SPK2_1

Description: External audio phone jack reserved connector

PIN	ASSIGNMENT
1	HD_FRONT-OUT-L
2	GND
3	HD_FRONT-OUT-R

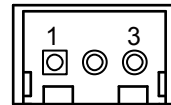

SPK2_1

Connector Name: GPIO1

Description: 2 ports GPIO & DC5V & DC3.3V reserved connector

PIN	ASSIGNMENT
1	GPIO1
2	GPIO2
3	5V (Maximum current: 0.5A)
4	3.3V ((Maximum current: 0.5A)
5	GND

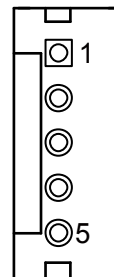

GPIO1

3.6.12 Panel Resolution Selection (JP5, JP6)

Jumper Name: JP5, JP6

Description: Panel resolution control connectors

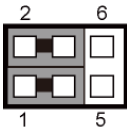
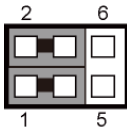
SELECTION	JUMPER SETTING	JUMPER ILLUSTRATION	
1280 x 800 (24 bit)	JP5: 1-3, 2-4 JP6: 1-3, 2-4	 <p>JP5</p>	 <p>JP6</p>

3.6.13 Mini PCIE USB Selection (JP13)

Jumper Name: JP13

Description: "USB6 signal support to" selection

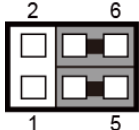
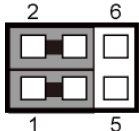
SELECTION	JUMPER SETTING	JUMPER ILLUSTRATION
USB signal to mini-PCIE	3-5, 4-6	 <p>JP13</p>
USB signal to USB6 wafer	1-3, 2-4 (Default Setting)	 <p>JP13</p>

3.6.14 MSR / Card Reader Connector (PS2)

Connector Name: PS2

Description: MSR / Card reader connector

PIN	ASSIGNMENT
1	KB_CLK (Output)
2	KB_CLK_C (Input)
3	KB_DATA_C (Input)
4	KB_DATA (Output)
5	+5V
6	GND

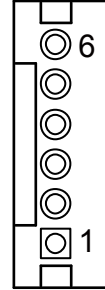

PS2

3.6.15 LVDS Connector (LVDS1)

Connector Name: LVDS1

Description: LVDS Connector

PIN	ASSIGNMENT	PIN	ASSIGNMENT
1	LVDS_VCC	2	PANEL_Reverse
3	LVDS_CLKB_D-	4	LVDS_CLKB_D+
5	GND	6	LVDS_B2_D-
7	LVDS_B2_D+	8	GND
9	LVDS_B1_D-	10	LVDS_B1_D+
11	LVDS_B3_D+	12	LVDS_B3_D-
13	LVDS_B0_D+	14	LVDS_B0_D-
15	GND	16	LVDS_CLKA_D+
17	VDS_CLKA_D-	18	GND
19	LVDS_A2_D+	20	LVDS_A2_D-
21	GND	22	LVDS_A1_D+
23	LVDS_A1_D-	24	GND
25	LVDS_A0_D+	26	LVDS_A0_D-
27	LVDS_A3_D+	28	LVDS_A3_D-
29	LVDS_VCC	30	LVDS_VCC

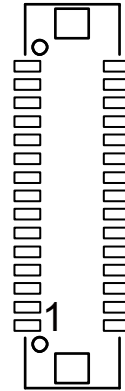



LVDS1

3.6.16 Touch Panel Signal Interface Selection (JP8, JP9)

Jumper Name: JP8, JP9

Description: Control connectors for touch panel signal interface

SELECTION	JUMPER SETTING	JUMPER ILLUSTRATION	
USB7 Connector	JP8: 1-2 JP9: 1-2	 <p style="text-align: center;">JP8</p>	 <p style="text-align: center;">JP9</p>

3.6.17 SATA & SATA Power Connector (SATA1, SATA2, SATA_PWR1, SATA_PWR2)

Connector Name: SATA1, SATA2

Description: Serial ATA connectors

PIN	ASSIGNMENT
1	G1
2	TX+
3	TX-
4	G2
5	RX-
6	RX+
7	G3

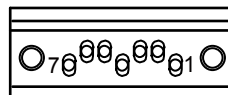

SATA1

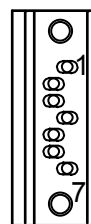

SATA2

Connector Name: SATA_PWR1, SATA_PWR2

Description: Serial ATA power connectors

PIN	ASSIGNMENT
1	VCC
2	GND
3	GND
4	VCC12

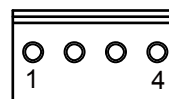

SATA_PWR1

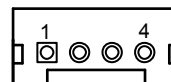



SATA_PWR2

3.6.18 BIOS Update Selection (JP1)

Jumper Name: JP1

Description: Update BIOS settings

SELECTION	JUMPER SETTING	JUMPER ILLUSTRATION
Normal	Open (Default Setting)	 JP1
Update BIOS*	1-2	 JP1

3.6.19 Clear CMOS Data Selection (JP2)

Jumper Name: JP2

Description: Clear CMOS Data Selection



Step 1. Remove the main power of the PC.

Step 2. Close JP2 (pins 1-2) for 6 seconds by a cap.

Step 3. Remove the cap which is just used on JP2 (1-2), so that JP2 returns to “OPEN”.

Step 4. Power on the PC and the PC will then auto-reboot for once in order to set SoC’s register.

Step 5. Done!

SELECTION	JUMPER SETTING	JUMPER ILLUSTRATION
Normal	Open (Default Setting)	 JP2
Clear CMOS*	1-2	 JP2

Note: Please make sure the main power is off before you clear CMOS data. .

3.6.20 LVDS Link (JP16)

Jumper Name: JP16

Description: LVDS Link

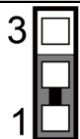
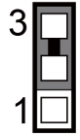
Selection	Jumper Setting	Jumper Illustration
5V	1-2	 <p>JP16</p>
0V	2-3	 <p>JP16</p>

Default Setting: NC (software controlled).

3.6.21 LVDS Voltage Selection (JP17)

Jumper Name: JP17

Description: LVDS Voltage Selection

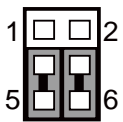
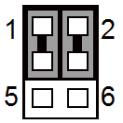
Selection	Jumper Setting	Jumper Illustration
3.3V	3-5, 4-6 <i>(Default Setting)</i>	 <p>JP17</p>
5V	1-3, 2-4	 <p>JP17</p>

3.6.22 Panel Enable Selection (JP20)

Jumper Name: JP20

Description: Panel Enable Selection

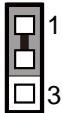
Selection	Jumper Setting	Jumper Illustration
Power Supply 5V	1-2	 <p>JP20</p>

3.6.23 Mini-PCIe Connector (M_PCI_E1)

Connector Name: M_PCI_E1

Description: Mini-PCIe connector, USB function not supported.

PIN	ASSIGNMENT	PIN	ASSIGNMENT
1	WAKE#	2	+3.3V
3	Reserved	4	GND
5	Reserved	6	+1.5V
7	CLKREQ#	8	Reserved
9	GND	10	Reserved
11	REFCLK1-	12	Reserved
13	REFCLK1+	14	Reserved
15	GND	16	Reserved
17	Reserved	18	GND
19	Reserved	20	Reserved
21	GND	22	PERST#
23	PERn0	24	+3.3SB
25	PERp0	26	GND
27	GND	28	+1.5V
29	GND	30	SMB_CLK
31	PETn2	32	SMB_DATA
33	PETp2	34	GND
35	GND	36	USB D-
37	GND	38	USB D+
39	+3.3V	40	GND
41	+3.3V	42	Reserved
43	GND	44	Reserved
45	NC	46	Reserved
47	NC	48	+1.5V
49	NC	50	GND
51	Reserved	52	+3.3V

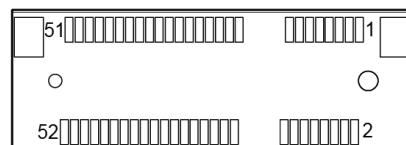

M_PCI_E1

3.7 Printer Board Component Locations & Pin Assignment

3.7.1 Printer Board: PDAC-3100

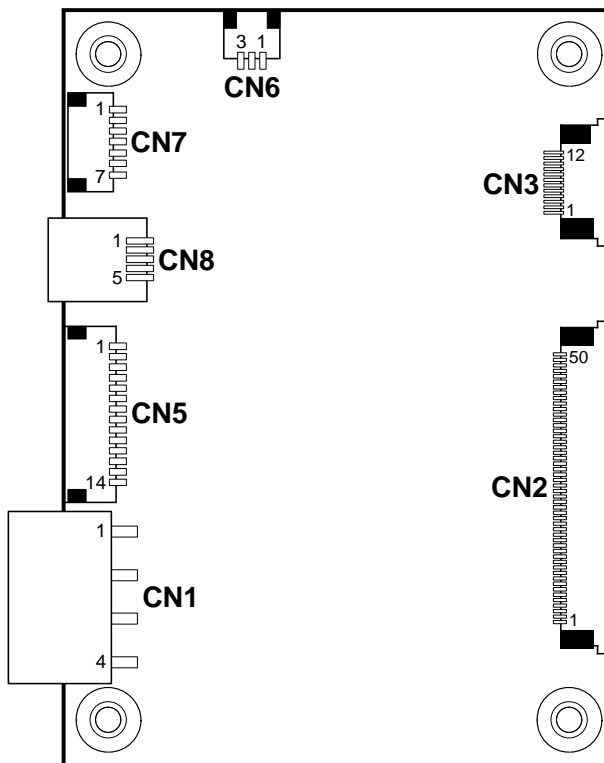

Figure 3-2. PDAC-3100 Printer Board Component Locations

3.7.2 Jumper & Connector Quick Reference Table

Jumper / Connector	NAME
Power Supply Connector	CN1
RS-232 Interface Connector	CN7
Auto-Cutter Connector	CN3
USB Connector	CN8
Thermal Head/Motor/Sensor Connector	CN2
Terminal Assignment Connector	CN5

3.7.3 Setting Printer Board Connectors and Jumpers: PDAC-3100

3.7.3.1 Power Supply Connector

CN1: Power supply wafer

PIN	ASSIGNMENT
1	+24V
2	+24V
3	GND
4	GND

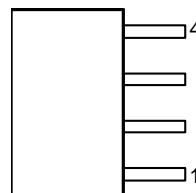

CN1

3.7.3.2 RS-232 Interface Connector

CN7: RS-232 interface connector

PIN	ASSIGNMENT	PIN	ASSIGNMENT
1	TXD	5	DTR
2	RXD	6	DSR
3	RTS	7	GND
4	CTS	-	-

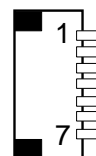

CN7

3.7.3.3 Auto-Cutter Connector

CN3: Auto-cutter wafer

PIN	ASSIGNMENT	FUNCTION
1	NC	Unused
2	Vcs	Power supply of the Home position sensor
3	GND	GND of the Home position sensor
4	CUTS	Signal of the Home position sensor
5	2B-1	Auto-cutter motor drive signal
6	2B-2	Auto-cutter motor drive signal
7	2A-1	Auto-cutter motor drive signal
8	2A-2	Auto-cutter motor drive signal
9	1B-1	Auto-cutter motor drive signal
10	1B-2	Auto-cutter motor drive signal
11	1A-1	Auto-cutter motor drive signal
12	1A-2	Auto-cutter motor drive signal

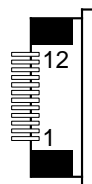

CN3

3.7.3.4 USB Connector

CN8: USB Connector

PIN	ASSIGNMENT	PIN	ASSIGNMENT
1	Vbus	4	NC
2	D-	5	GND
3	D+	-	-

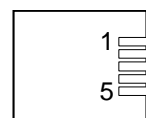

CN8

3.7.3.5 Thermal Head/Motor/Sensor Connector

CN2: Thermal head/motor/sensor connector

PIN	ASSIGNMENT	FUNCTION
1	24V	Head drive power
2	24V	Head drive power
3	24V	Head drive power
4	24V	Head drive power
5	24V	Head drive power
6	24V	Head drive power
7	DAT	Print data output
8	CLK	Synchronizing signal for print data transfer
9	GND	Head GND
10	GND	Head GND
11	GND	Head GND
12	GND	Head GND
13	GND	Head GND
14	GND	Head GND
15	NC	Unused
16	DST4	Head strobe signal
17	DST3	Head strobe signal
18	3.3V	Logic Power
19	GND	Thermistor GND
20	GND	Thermistor GND
21	TH	Thermistor signal
22	NC	Unused
23	DST2	Head strobe signal
24	DST1	Head strobe signal
25	GND	Head GND
26	GND	Head GND
27	GND	Head GND
28	GND	Head GND
29	GND	Head GND
30	GND	Head GND
31	LATCH	Print data latch
32	24V	Head drive power
33	24V	Head drive power
34	24V	Head drive power
35	24V	Head drive power

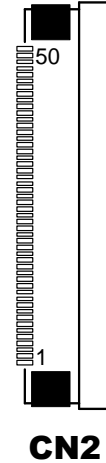

PIN	ASSIGNMENT	FUNCTION
36	24V	Head drive power
37	24V	Head drive power
38	NC	Unused
39	PS	Signal of the out-of-paper sensor
40	Vps	Power supply of the out-of-paper sensor
41	GND	GND of the platen position/ out-of-paper sensor
42	HS	Signal of the platen position sensor
43	NC	Unused
44	FG	Frame GND
45	FG	Frame GND
46	NC	Unused
47	2A	Motor drive signal
48	1B	Motor drive signal
49	1A	Motor drive signal
50	2B	Motor drive signal

3.7.3.6 Terminal Assignment Connector

CN5: Terminal assignment connector

PIN	ASSIGNMENT	FUNCTION
1	FEED	Feed signal
2	RESET	Reset signal
3	GND	GND
4	ST1	Status signal
5	ST2	Status signal
6	ST3	Status signal
7	ST4	Status signal
8	GND	GND
9	DRS	Drawer sensor signal
10	DSW	Drawer switch signal
11	Vdu	Drive terminal for the drawer (Vp side)
12	GNDdu	Drive terminal for the drawer (GND side)
13	GND	GND
14	NC	Unused

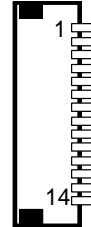

CN5

3.7.4 Printer Board: MB-1030 series

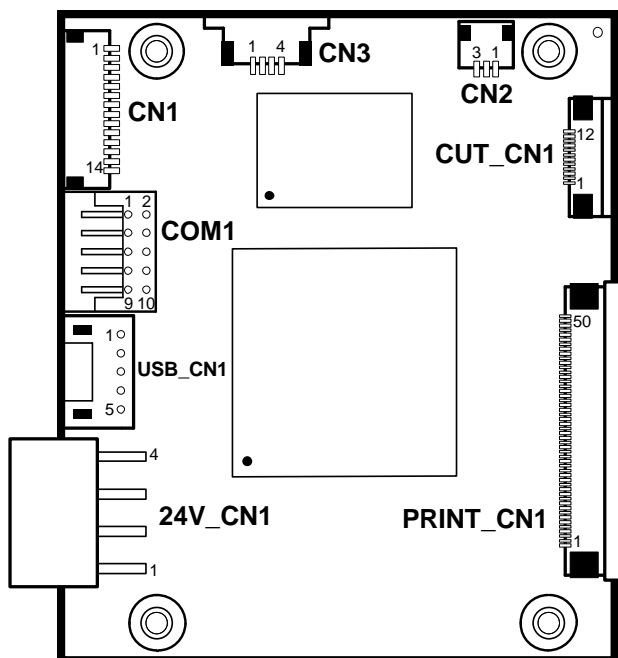

Figure 3-3. MB-1030 Printer Board Component Locations

3.7.4.1 Jumper & Connector Quick Reference Table

Jumper / Connector	NAME
Power Supply Connector	24V_CN1
RS-232 Interface Connector	COM1
Thermal Head/Motor/Sensor Connector	PRINT_CN1
Auto-Cutter Connector	CUT_CN1
Paper-Near-END Sensor Connector	CN2
USB Interface Connector	USB_CN1
Terminal Assignment Connector	CN1

3.7.5 Setting Printer Board Connectors and Jumpers

3.7.5.1 Power Supply Connector

24V_CN1: Power Supply Wafer

PIN	ASSIGNMENT
1	GND
2	GND
3	+24V
4	+24V

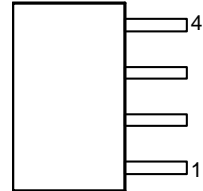

24V_CN1

3.7.5.2 RS-232 Interface Connector

COM1: RS-232 Interface Connector

PIN	ASSIGNMENT	PIN	ASSIGNMENT
1	NC	6	DSR /CTS
2	RXD	7	RTS
3	TXD	8	CTS
4	DTR /RTS	9	NC
5	GND	10	NC

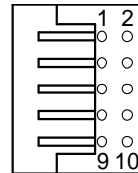

COM1

3.7.5.3 Thermal Head/Motor/Sensor Connector

PRINT_CN1: Thermal head/motor/sensor connector

PIN	ASSIGNMENT	FUNCTION
1	24V	Head drive power
2	24V	Head drive power
3	24V	Head drive power
4	24V	Head drive power
5	24V	Head drive power
6	24V	Head drive power
7	DAT	Print data output
8	CLK	Synchronizing signal for print data transfer
9	GND	Head GND
10	GND	Head GND
11	GND	Head GND
12	GND	Head GND
13	GND	Head GND
14	GND	Head GND
15	NC	Unused
16	DST4	Head strobe signal
17	DST3	Head strobe signal
18	3.3V	Logic Power
19	GND	Thermistor GND
20	GND	Thermistor GND
21	TH	Thermistor signal
22	NC	Unused
23	DST2	Head strobe signal
24	DST1	Head strobe signal
25	GND	Head GND
26	GND	Head GND
27	GND	Head GND
28	GND	Head GND
29	GND	Head GND
30	GND	Head GND
31	LATCH	Print data latch
32	24V	Head drive power
33	24V	Head drive power
34	24V	Head drive power
35	24V	Head drive power

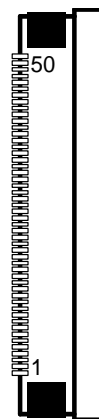

PRINT_CN1

PIN	ASSIGNMENT	FUNCTION
36	24V	Head drive power
37	24V	Head drive power
38	NC	Unused
39	PS	Signal of the out-of-paper sensor
40	Vps	Power supply of the out-of-paper sensor
41	GND	GND of the platen position/ out-of-paper sensor
42	HS	Signal of the platen position sensor
43	NC	Unused
44	FG	Frame GND
45	FG	Frame GND
46	NC	Unused
47	2A	Motor drive signal
48	1B	Motor drive signal
49	1A	Motor drive signal
50	2B	Motor drive signal

3.7.5.4 Auto-Cutter Connector

CUT_CN1: Auto-cutter Connector

PIN	ASSIGNMENT	FUNCTION
1	NC	Unused
2	Vcs	Power supply of the Home position sensor
3	GND	GND of the Home position sensor
4	CUTS	Signal of the Home position sensor
5	2B-1	Auto-cutter motor drive signal
6	2B-2	Auto-cutter motor drive signal
7	2A-1	Auto-cutter motor drive signal
8	2A-2	Auto-cutter motor drive signal
9	1B-1	Auto-cutter motor drive signal
10	1B-2	Auto-cutter motor drive signal
11	1A-1	Auto-cutter motor drive signal
12	1A-2	Auto-cutter motor drive signal

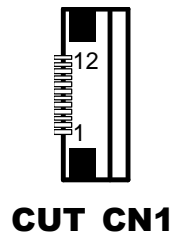

3.7.5.5 Paper-Near-END Sensor Connector

CN2: Paper-near-end sensor connector

PIN	ASSIGNMENT	FUNCTION
1	Vns	Power supply of the near end sensor
2	NS	Signal of the near end sensor
3	GND	GND of the near end sensor



3.7.5.6 USB Interface Connector

USB_CN1: USB interface connector

PIN	ASSIGNMENT	PIN	ASSIGNMENT
1	Vbus	4	GND
2	D-	5	GND
3	D+	-	-

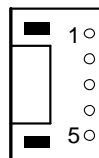

USB_CN1

3.7.5.7 Terminal Assignment Connector

CN1: Terminal assignment connector

PIN	ASSIGNMENT	FUNCTION
1	FEED	Feed signal
2	RESET	Reset signal
3	GND	GND
4	ST1	Status signal
5	ST2	Status signal
6	ST3	Status signal
7	ST4	Status signal
8	GND	GND
9	DRS	Drawer sensor signal
10	DSW	Drawer switch signal
11	Vdu	Drive terminal for the drawer (Vp side)
12	GNDdu	Drive terminal for the drawer (GND side)
13	GND	GND
14	NC	Unused

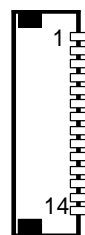

CN1

3.7.6 Printer Board: MB-1011 & MB-1013

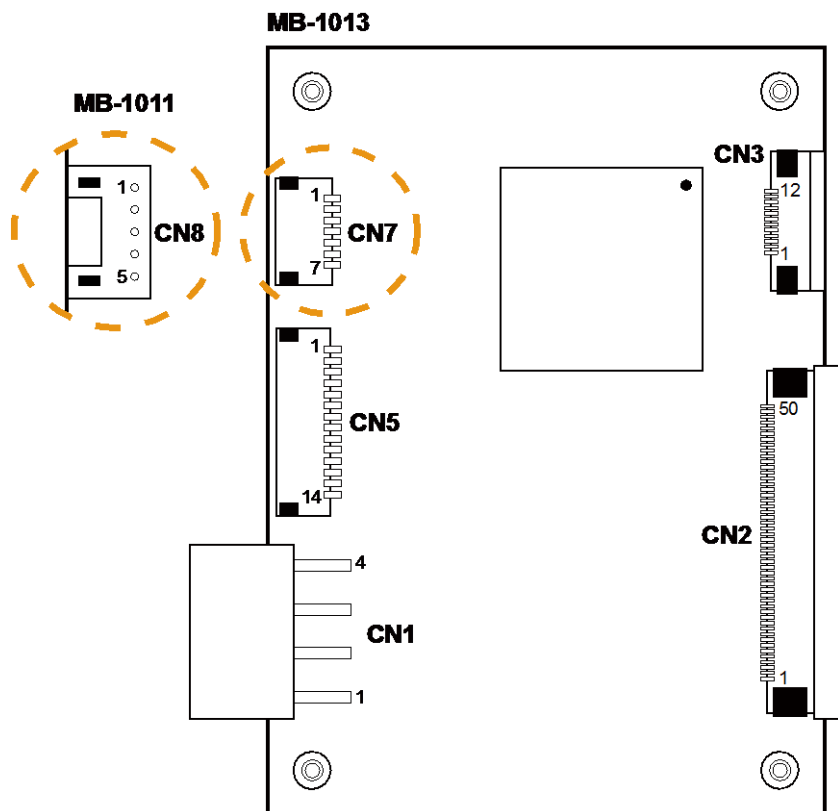

Figure 3-4. MB-1011 & MB-1013 Printer Board Component Locations

3.7.6.1 Jumper & Connector Quick Reference Table

Jumper / Connector	NAME
Power Supply Connector	CN1
RS-232 Interface Connector	CN7
Auto-Cutter Connector	CN3
Thermal Head/Motor/Sensor Connector	CN2
Terminal Assignment Connector	CN5
USB Interface Connector	CN8

3.7.7 Setting Printer Board Connectors and Jumpers: MB-1011 & MB-1013

3.7.7.1 Power Supply Connector

CN1: Power supply wafer

PIN	ASSIGNMENT
1	GND
2	GND
3	+24V
4	+24V

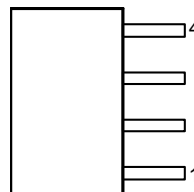

CN1

3.7.7.2 RS-232 Interface Connector

CN7: RS-232 interface connector

PIN	ASSIGNMENT	PIN	ASSIGNMENT
1	TXD	5	DTR
2	RXD	6	DSR
3	RTS	7	GND
4	CTS	-	-

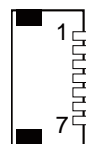

CN7

3.7.7.3 Auto-Cutter Connector

CN3: Auto-cutter Connector

PIN	ASSIGNMENT	FUNCTION
1	NC	Unused
2	Vcs	Power supply of the Home position sensor
3	GND	GND of the Home position sensor
4	CUTS	Signal of the Home position sensor
5	2B-1	Auto-cutter motor drive signal
6	2B-2	Auto-cutter motor drive signal
7	2A-1	Auto-cutter motor drive signal
8	2A-2	Auto-cutter motor drive signal
9	1B-1	Auto-cutter motor drive signal
10	1B-2	Auto-cutter motor drive signal
11	1A-1	Auto-cutter motor drive signal
12	1A-2	Auto-cutter motor drive signal

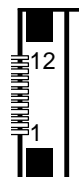

CN3

3.7.7.4 Thermal Head/Motor/Sensor Connector

CN2: Thermal head/motor/sensor connector

PIN	ASSIGNMENT	FUNCTION
1	24V	Head drive power
2	24V	Head drive power
3	24V	Head drive power
4	24V	Head drive power
5	24V	Head drive power
6	24V	Head drive power
7	DAT	Print data output
8	CLK	Synchronizing signal for print data transfer
9	GND	Head GND
10	GND	Head GND
11	GND	Head GND
12	GND	Head GND
13	GND	Head GND
14	GND	Head GND
15	NC	Unused

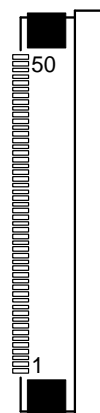

CN2

PIN	ASSIGNMENT	FUNCTION
16	DST4	Head strobe signal
17	DST3	Head strobe signal
18	3.3V	Logic Power
19	GND	Thermistor GND
20	GND	Thermistor GND
21	TH	Thermistor signal
22	NC	Unused
23	DST2	Head strobe signal
24	DST1	Head strobe signal
25	GND	Head GND
26	GND	Head GND
27	GND	Head GND
28	GND	Head GND
29	GND	Head GND
30	GND	Head GND
31	LATCH	Print data latch
32	24V	Head drive power
33	24V	Head drive power
34	24V	Head drive power
35	24V	Head drive power
36	24V	Head drive power
37	24V	Head drive power
38	NC	Unused
39	PS	Signal of the out-of-paper sensor
40	Vps	Power supply of the out-of-paper sensor
41	GND	GND of the platen position/ out-of-paper sensor
42	HS	Signal of the platen position sensor
43	NC	Unused
44	FG	Frame GND
45	FG	Frame GND
46	NC	Unused
47	2A	Motor drive signal
48	1B	Motor drive signal
49	1A	Motor drive signal
50	2B	Motor drive signal

3.7.7.5 Terminal Assignment Connector

CN5: Terminal assignment connector

PIN	ASSIGNMENT	FUNCTION
1	FEED	Feed signal
2	RESET	Reset signal
3	GND	GND
4	ST1	Status signal
5	ST2	Status signal
6	ST3	Status signal
7	ST4	Status signal
8	GND	GND
9	DRS	Drawer sensor signal
10	DSW	Drawer switch signal
11	Vdu	Drive terminal for the drawer (Vp side)
12	GNDdu	Drive terminal for the drawer (GND side)
13	GND	GND
14	NC	Unused

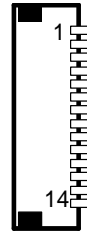

CN5

3.7.7.6 USB Interface Connector

CN8: USB interface connector

PIN	ASSIGNMENT
1	Vbus
2	D-
3	D+
4	GND
5	GND

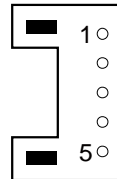

CN8

3.8 VFD Board Component Locations & Pin Assignment

3.8.1 VFD Board: MB-4103, LD720

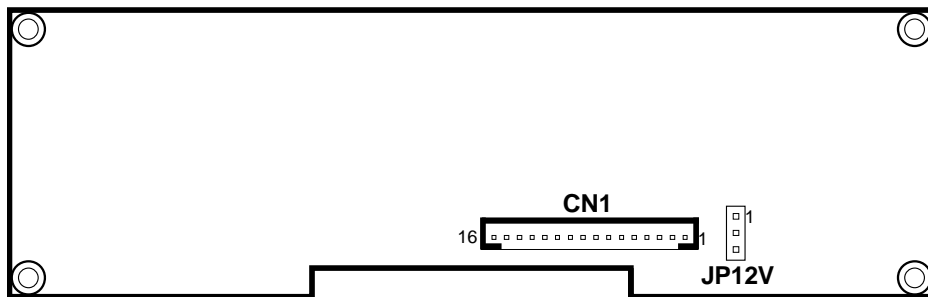

Figure 3-5. MB-4103 & LD720 VFD Board Component Locations

3.8.2 Jumper & Connector Quick Reference Table

Jumper / Connector	NAME
Power Switch Selection	JP12V
RS-232 Serial Interface Connector	CN1

3.8.3 Setting MB-4103 & LD720 VFD Board Connectors and Jumpers

3.8.3.1 Power Switch Selection

JP12V: Power Switch Selection

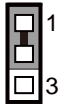
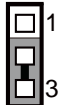
SELECTION	JUMPER SETTING	JUMPER ILLUSTRATION
OFF	1-2	 <p>JP12V</p>
ON (Default)	2-3	 <p>JP12V</p>

3.8.3.2 RS-232 Serial Interface Connector

CN1: RS-232 serial interface wafer

PIN	ASSIGNMENT	PIN	ASSIGNMENT
1	GND	9	NC
2	TXD	10	NC
3	RXD	11	NC
4	DTR	12	NC
5	DSR	13	NC
6	RTS	14	NC
7	CTS	15	NC
8	+12V/+5V	16	NC

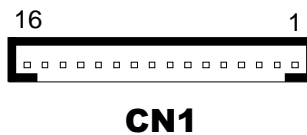

3.9 MSR Board Component Locations & Pin Assignment

3.9.1 ID TECH



ID-TECH MSR Board Component Locations

3.9.1.1 Main Connector

CN:

PIN	ASSIGNMENT	PIN	ASSIGNMENT
1	Chassis Ground	5	K-CLK (Computer connections)
2	P-CLK (Keyboard connections)	6	K-DATA (Computer connections)
3	P-DATA (Keyboard connections)	7	GND
4	+5V Vcc	-	-

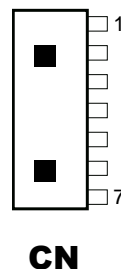

3.9.2 MB-3012

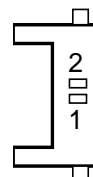

Figure 3-6. MB-3012 MSR Board Component Locations

3.9.2.1 Information Button Reader

I_BUTTON1: Information button reader

PIN	ASSIGNMENT
1	I_B1
2	GND



I_BUTTON1

3.9.2.2 Output Connector

IO1: Output wafer

PIN	ASSIGNMENT	PIN	ASSIGNMENT
1	CLK_KB	7	RX_MSR
2	CLK_PC	8	TX_MSR
3	DATA_KB	9	GND
4	DATA_PC	10	USB_D+_R
5	+5V	11	USB_D-_R
6	CHASSIS GND	12	GND



IO1

4 Software Utilities

This chapter provides the detailed information that guides users to install driver utilities for the system. The following topics are included:

- Installing Intel® Chipset Software Installation Utility
- Installing Graphics Driver Utility
- Installing LAN Driver Utility
- Installing Sound Driver Utility
- Installing Fingerprint Driver Utility (Optional)
- Installing RFID Module Driver Utility (Optional)
- Installing Wireless Module Driver Utility (Optional)
- Peripheral Devices
 - Printer
 - VFD
 - MSR
- API

4.1 Introduction

Enclosed with the PA-3222 Series package is our driver utilities contained in a DVD-ROM disk. Refer to the following table for driver locations:

Filename (Assume that DVD- ROM drive is D :)	Purpose	OS		
		Win7 (32/64-bit)	Win8.1 (32/64-bit)	Win10 (32/64-bit)
D:\Driver\ Chipset	Main Chip /INTEL /BayTrail J1900	✓	✓	✓
D:\Driver\ Graphics	Graphic /INTEL /BayTrail J1900	✓	✓	✓
D:\Driver\LAN	LAN Chip /REALTEK /RTL8119-CG	✓	✓	✓
D:\Driver\Sound	Sound Codec /REALTEK /ALC888S-VD2-GR	✓	✓	✓
D:\Driver\ Intel TXE Firmware	Intel TXE Firmware	✓	✓	✓
D:\Driver\ Windows 7 update KMDF	Windows 7 update KMDF	✓	X	X
D:\Driver\ USB3.0	Intel_USB_3.0_xHC_Driver	✓	X	X

X : Not support

✓ : Support

Note: Install the driver utilities immediately after the OS installation is completed.

4.2 Installing Intel® Chipset Software Installation Utility

Introduction

The Intel® Chipset Software Installation Utility installs Windows *.INF files to the target system. These files outline to the operating system how to configure the Intel chipset components in order to ensure the following features function properly:

- SATA Storage Support (SATA & SATA II)
- USB Support (1.1 & 2.0 & 3.0)
- Identification of Intel® Chipset Components in Device Manager

4.2.1 Installing Intel® Chipset Driver

The utility pack is to be installed only for POSReady 7 & Windows® 8.1 & Windows® 10 series, and it should be installed right after the OS installation. Please follow the steps below:

- 1** Connect the USB DVD-ROM device to PA-3222 and insert the driver disk.
- 2** Enter the “Main Chip” folder where the Chipset driver is located (depending on your OS platform).
- 3** Click **Setup.exe** file for driver installation.
- 4** Follow the on-screen instructions to complete the installation.
- 5** Once the installation is completed, shut down the system and restart PA-3222 for the changes to take effect.

4.3 Installing VGA Driver Utility

The VGA interface embedded with PA-3222 can support a wide range of display types. You can have dual displays via CRT & LVDS interfaces work simultaneously.

To install the Graphics driver, follow the steps below:

- 1** Connect the USB DVD-ROM device to PA-3222 and insert the driver disk.
- 2** Enter the “VGA” folder where the VGA driver is located (depending on your OS platform).
- 3** Click **Setup.exe** file for driver installation.
- 4** Follow the on-screen instructions to complete the installation.
- 5** Once the installation is completed, shut down the system and restart PA-3222 for the changes to take effect.

4.4 Installing LAN Driver Utility

PA-3222 is enhanced with LAN function that can support various network adapters.

To install the LAN Driver, follow the steps below:

- 1** Connect the USB DVD-ROM device to PA-3222 and insert the driver disk.

- 2** Enter the “LAN” folder where the LAN driver is located (depending on your OS platform).
- 3** Click **Setup.exe** file for driver installation.
- 4** Follow the on-screen instructions to complete the installation.
- 5** Once the installation is completed, shut down the system and restart PA-3222 for the changes to take effect.

For more details on the Installation procedure, please refer to the Readme.txt file found on LAN Driver Utility.

4.5 Installing Sound Driver Utility

The sound function enhanced in this system is fully compatible with POSReady 7 & Windows® 8.1 & Windows® 10 series.

To install the Sound Driver, follow the steps below:

- 1** Connect the USB DVD-ROM device to PA-3222 and insert the driver disk.
- 2** Enter the “Sound” folder where the sound driver is located (depending on your OS platform).
- 3** Click **Setup.exe** file for driver installation.
- 4** Follow the on-screen instructions to complete the installation.
- 5** Once the installation is completed, shut down the system and restart PA-3222 for the changes to take effect.

4.6 Installing Fingerprint Driver Utility (Optional)

The fingerprint driver utility can only be installed on a Windows platform, and it should be installed right after the OS installation.

To install the fingerprint driver, follow the steps below:

- 1** Connect the USB DVD-ROM device to PA-3222 and insert the driver disk.
- 2** Enter the “Device\Embedded Finger Printer” folder where the fingerprint driver is located.
- 3** Click **Setup.exe** file for driver installation.
- 4** Follow the on-screen instructions to complete the installation.
- 5** Once the installation is completed, shut down the system and restart PA-3222 for the changes to take effect.

4.7 Installing RFID Module Driver Utility (Optional)

The RFID driver utility can only be installed on POSReady 7 & Windows® 8.1 & Windows® 10 series, and it should be installed right after the OS installation.

To install the RFID module driver, follow the steps below:

- 1** Connect the USB DVD-ROM device to PA-3222 and insert the driver disk.
- 2** Enter the “Device\RFID Module” folder where the RFID Module driver is located.
- 3** Click **Autorun.exe** file for driver installation.
- 4** Select **Mifare Demo Software V1.5R8**.

- 5** Follow the on-screen instructions to complete the installation.
- 6** Once the installation is completed, shut down the system and restart PA-3222 for the changes to take effect.

4.8 Installing Wireless Module Driver Utility (Optional)

The wireless driver utility can only be installed on POSReady 7 & Windows® 8.1 & Windows® 10 series, and it should be installed right after the OS installation.

To install the wireless driver, follow the steps below:

- 1** Connect the USB DVD-ROM device to PA-3222 and insert the driver disk.
- 2** Enter the “Device\Embedded Wireless Module” folder where the wireless driver is located.
- 3** Click **Setup.exe** file for driver installation.
- 4** Follow the on-screen instructions to complete the installation.
- 5** Once the installation is completed, shut down the system and restart PA-3222 for the changes to take effect.

4.9 Peripheral Devices

The Commands lists and driver installation guide for embedded peripheral devices of the system - printer board, VFD and MSR – are explicitly included in this section.

4.9.1 Printer Board: MB-1030

4.9.1.1 Commands List

1. Printer Registry Operation

Registry Name	Default Data	Notes
BaudRate	115200	-
BitLength	8	-
Parity	N	-
Stop	1	-

1. Commands List

Standard Commands

Command	RA	RB	Command	RA	RB	Command	RA	RB
HT		V	ESC D		V	GS /	V	V
LF	V	V	ESC E	V	V	GS :		
FF		V	ESC G		V	GS B	V	V
CR	V	V	ESC J	V	V	GS H	V	V
CAN		V	ESC L		V	GS I	V	V
DLE EOT	V	V	ESC M	V	V	GS L	V	V
DLE ENQ		V	ESC c 4		V	GS P	V	V
DLE DC4	V	V	ESC c 5		V	GS V	V	V
ESC FF		V	ESC d	V	V	GS W		V
ESC SP	V	V	ESC p	V	V	GS \		
ESC !	V	V	ESC t	V	V	GS ^		
ESC \$	V	V	ESC {	V	V	GS a	V	V
ESC %			FS g 1			GS b		
ESC &			FS g 2			GS f	V	V
ESC *		V	FS p	V	V	GS h	V	V
ESC	V	V	FS q	V	V	GS k	V	V
ESC 2	V	V	GS !	V	V	GS r	V	V
ESC 3	V	V	GS \$		V	GS v 0	V	V
ESC =	V	V	GS *	V	V	GS w	V	V
ESC ?			GS (A	V	V			
ESC @	V	V	GS (K		V			

Kanji Control Commands

Command	MB-1030 RA	MB-1030 RB
FS !	V	V
FS &	V	V
FS		V
FS .	V	V
FS 2		
FS C		
FS S		V
FS W		V

Other Commands

Command	MB-1030 RA	MB-1030 RB
ESC i	V	V
ESC m	V	V
DC2 ;		V
GS p 1		V

COMMANDS LIST

Standard Commands

Control Codes	Hexadecimal Codes	Function	Standard Mode	Page Mode
<HT>	09	Horizontal tab	V	V
<LF>	0A	Print and line feed	V	V
<FF>	0C	Print and recover to standard mode (in page mode)	Ignored	V
<CR>	0D	Print and carriage return	V	V
<CAN>	18	Cancel print data in page mode	Ignored	V
<DLE EOT>	10 04	Real-time status transmission	V	V
<DLE ENQ>	10 05	Real-time request to printer	V	V
<DLE DC4>	10 14	Real-time output of specified pulse	V	V
<ESC FF>	1B 0C	Print data in page mode	Ignored	V
<ESC SP>	1B 20	Set right-side character spacing	V	V
<ESC !>	1B 21	Select print mode(s)	V	V
<ESC \$>	1B 24	Set absolute print position.	V	V
<ESC *>	1B 2A	Select bit image mode	V	V

Control Codes	Hexadecimal Codes	Function	Standard Mode	Page Mode
<ESC ->	1B 2D	Turn underline mode on/off.	V	V
<ESC 2>	1B 32	Select default line spacing	V	V
<ESC 3>	1B 33	Set line spacing	V	V
<ESC =>	1B 3D	Select peripheral device	V	V
<ESC @>	1B 40	Initialize printer	V	V
<ESC D>	1B 44	Set horizontal tab position	V	V
<ESC E>	1B 45	Turn emphasized mode on/off	V	V
<ESC G>	1B 47	Turn double-strike mode on/off	V	V
<ESC J>	1B 4A	Print and feed paper	V	V
<ESC L>	1B 4C	Select page mode	⊙	Ignored
<ESC M >	1B 4D	Select character font	V	V
<ESC R>	1B 52	Select an international character set	V	V
<ESC S>	1B 53	Select standard mode	Ignored	V
<ESC T>	1B 54	Select print direction in page mode	▲	V
<ESC V>	1B 56	Turn 90 degree clockwise rotation mode on/off	V	▲
<ESC W>	1B 57	Set printing area in page mode	▲	V
<ESC \>	1B 5C	Set relative print position	V	V
<ESC a>	1B 61	Select justification	⊙	▲
<ESC c 3>	1B 63 33	Select paper sensor(s) to output paper-end signals	V	V
<ESC c 4>	1B 63 34	Select paper sensor(s) to stop printing	V	V
<ESC c 5>	1B 63 35	Enable/disable panel buttons	V	V
<ESC d>	1B 64	Print and feed n lines	V	V
<ESC i>	1B 69	Full cut	V	Disabled
<ESC m>	1B 6D	Partial cut	V	Disabled
<ESC p>	1B 70	General pulse	V	V
<ESC t>	1B 74	Select character code table	V	V
<ESC {>	1B 7B	Turn upside-down printing mode on/off	⊙	▲
<FS p>	1C 70	Print NV bit image	V	Disabled
<FS q>	1C 71	Define NV bit image	⊙	Disabled
<GS !>	1D 21	Select character size		V
<GS \$>	1D 24	Set absolute vertical print position in page mode	Ignored	V
<GS *>	1D 2A	Define download bit images	V	V
<GS (A>	1D 28 41	Execute test print	V	Disabled
<GS (K>	1D 28 4B	Set print density	V	Disabled
<GS />	1D 2F	Print download bit image	●	V

Control Codes	Hexadecimal Codes	Function	Standard Mode	Page Mode
<GS B>	1D 42	Turn white/black reverse printing mode on/off	V	V
<GS H>	1D 48	Select printing position of HRI characters	V	V
<GS I>	1D 49	Transmit printer ID	V	Disabled
<GS L>	1D 4C	Set left margin	⊙	Disabled
<GS P>	1D 50	Set basic calculated pitch	V	V
<GS V>	1D 56	Cut paper	⊙	V
<GS W>	1D 57	Set printing area width	⊙	▲
<GS \>	1D 5C	Set relative vertical print position in page mode	Ignored	
<GS a>	1D 61	Enable/disable Automatic Status Back (ASB)	V	V
<GS f>	1D 66	Select font for HRI characters	V	V
<GS h>	1D 68	Set bar code height	V	V
<GS k>	1D 6B	Print bar code	•	V
<GS r>	1D 72	Transmit status	V	V
<GS v 0>	1D 76 30	Print raster bit image	•	Disabled
<GS w>	1D 77	Set bar code width	V	V

Two-dimensional Bar Code Commands

Control Codes	Hexadecimal Code	Function	Standard Mode	Page Mode
<DC2 ;>	12 3B	Specifies a module size of QR Code and Data Matrix	√	√
<GS p 1>	1D 70 01	Prints QR Code data based on the specified contents	√	√

Kanji Control Commands

(when the Japanese, Simplified Chinese, Traditional Chinese, or Korean model is used.)

Control Codes	Hexadecimal Codes	Function	Standard Mode	Page Mode
<FS !>	1C 21	Set print mode(s) for Kanji characters	√	√
<FS &>	1C 26	Select Kanji character mode	√	√
<FS ->	1C 2D	Turn underline mode on/off for Kanji characters	√	√
<FS .>	1C 2E	Cancel Kanji character mode	√	√
<FS S>	1C 53	Set Kanji character spacing	√	√
<FS W>	1C 57	Turn quadruple-size mode on/off for Kanji characters	√	√

Command classification

Executing : Printer executes the command which does not affect the following data.

Setting: Printer uses flags to make settings, and those settings affect the following data.

○: Enabled.

⊙: Enabled only when the command is set at the beginning of a line.

●: Enabled only when data is not present in the printer buffer.

▲: Only value setting is possible.

Disabled: Parameters are processed as printable data.

Ignored: All command codes including parameters are ignored and nothing is executed.

COMMANDS DETAILS
STANDARD COMMAND DETAILS
HT

[Name]	Horizontal tab
[Format]	ASCII HT Hex. 09 Decimal 9
[Range]	N/A
[Description]	<p>Moves print position to next horizontal tab position.</p> <ul style="list-style-type: none"> • This command is ignored if the next tab is not set. • If the next tab position exceeds the print region, the print position is moved to [print region + 1]. • The horizontal tab position is set by ESC D (Set/cancel horizontal tab position). • When the print position is at the [print region + 1] position and this command is received, the current line buffer full is printed and a horizontal tab is executed from the top of the next line. • The initial value of the horizontal tab position is every 8 characters of Font A (the 9th, 17th, 25th positions, etc.)

LF

[Name]	Print and line feed
[Format]	ASCII LF Hex. 0A Decimal 10
[Range]	N/A
[Description]	<p>Prints the data in the print buffer and performs a line feed based on the set line feed amount.</p> <ul style="list-style-type: none"> • After execution, makes the top of the line the next print starting position.

FF

[Name]	Print and recover to standard mode (in page mode)
[Format]	ASCII FF Hex. 0C Decimal 12
[Range]	N/A
[Description]	<p>Prints all buffered data to the print region collectively, then recovers to the standard mode.</p>

	<ul style="list-style-type: none">● All buffer data is deleted after printing.● The print area set by ESC W (Set print region in page mode) is reset to the default setting.● No paper cut is executed.● Sets the print position to the beginning of the next line after execution.● This command is enabled only in page mode.
--	-----------------------------------------------------------------------------------------------------------------------------------------------------------------------------------------------------------------------------------------------------------------------------------------------------------------------------------------------------------------------------------

CR

[Name]	Print and carriage return
[Format]	ASCII CR Hex. 0D Decimal 13
[Range]	N/A
[Description]	When an automatic line feed is enabled, this command functions in the same way as LF (print and line feed). When the automatic line feed is disabled, this command is ignored. <ul style="list-style-type: none">● This command is ignored with serial interface models.● Sets the print position to the beginning of the next line after execution.

CAN

[Name]	Cancel print data in page mode
[Format]	ASCII CAN Hex. 18 Decimal 24
[Range]	N/A
[Description]	Deletes all print data in the currently set print region in page mode. <ul style="list-style-type: none">● This command is enabled only in page mode.● Portions included in the currently set print region are also deleted, even if previously set print region data.

DLE EOT n

[Name]	Real-time status transmission.																																																								
[Format]	ASCII OLE EOT n Hex. 10 04 n Decimal 16 4 n																																																								
[Range]	$1 \leq n \leq 4$																																																								
[Description]	Transmits the selected printer status specified by n in real time, according to the following parameters: n = 1 : Transmit printer status. n = 2 : Transmit off-line status. n = 3 : Transmit error status. n = 4 : Transmit paper roll sensor status.																																																								
	n = 1 : Printer status.																																																								
	<table border="1"> <thead> <tr> <th>Bit</th> <th>On / Off</th> <th>Hex</th> <th>Decimal</th> <th>Function</th> </tr> </thead> <tbody> <tr> <td>0</td> <td>Off</td> <td>00</td> <td>0</td> <td>Not used. Fixed to Off.</td> </tr> <tr> <td>1</td> <td>On</td> <td>02</td> <td>2</td> <td>Not used. Fixed to On.</td> </tr> <tr> <td rowspan="2">2</td> <td>Off</td> <td>00</td> <td>0</td> <td>Drawer open/close signal is LOW.</td> </tr> <tr> <td>On</td> <td>04</td> <td>4</td> <td>Drawer open/close signal is HIGH.</td> </tr> <tr> <td rowspan="2">3</td> <td>Off</td> <td>00</td> <td>0</td> <td>On-line.</td> </tr> <tr> <td>On</td> <td>08</td> <td>8</td> <td>Off-line.</td> </tr> <tr> <td>4</td> <td>On</td> <td>10</td> <td>16</td> <td>Not used. Fixed to On.</td> </tr> <tr> <td>5</td> <td>Off</td> <td>00</td> <td>0</td> <td>Not used. Fixed to Off.</td> </tr> <tr> <td>6</td> <td>Off</td> <td>00</td> <td>0</td> <td>Not used. Fixed to Off.</td> </tr> <tr> <td>7</td> <td>Off</td> <td>00</td> <td>0</td> <td>Not used. Fixed to Off.</td> </tr> </tbody> </table>	Bit	On / Off	Hex	Decimal	Function	0	Off	00	0	Not used. Fixed to Off.	1	On	02	2	Not used. Fixed to On.	2	Off	00	0	Drawer open/close signal is LOW.	On	04	4	Drawer open/close signal is HIGH.	3	Off	00	0	On-line.	On	08	8	Off-line.	4	On	10	16	Not used. Fixed to On.	5	Off	00	0	Not used. Fixed to Off.	6	Off	00	0	Not used. Fixed to Off.	7	Off	00	0	Not used. Fixed to Off.			
	Bit	On / Off	Hex	Decimal	Function																																																				
	0	Off	00	0	Not used. Fixed to Off.																																																				
	1	On	02	2	Not used. Fixed to On.																																																				
	2	Off	00	0	Drawer open/close signal is LOW.																																																				
		On	04	4	Drawer open/close signal is HIGH.																																																				
	3	Off	00	0	On-line.																																																				
		On	08	8	Off-line.																																																				
	4	On	10	16	Not used. Fixed to On.																																																				
	5	Off	00	0	Not used. Fixed to Off.																																																				
	6	Off	00	0	Not used. Fixed to Off.																																																				
	7	Off	00	0	Not used. Fixed to Off.																																																				
	n = 2 : Off-line status.																																																								
<table border="1"> <thead> <tr> <th>Bit</th> <th>On / Off</th> <th>Hex</th> <th>Decimal</th> <th>Function</th> </tr> </thead> <tbody> <tr> <td>0</td> <td>Off</td> <td>00</td> <td>0</td> <td>Not used. Fixed to Off.</td> </tr> <tr> <td>1</td> <td>On</td> <td>02</td> <td>2</td> <td>Not used. Fixed to On.</td> </tr> <tr> <td rowspan="2">2</td> <td>Off</td> <td>00</td> <td>0</td> <td>Cover is closed.</td> </tr> <tr> <td>On</td> <td>04</td> <td>4</td> <td>Cover is open.</td> </tr> <tr> <td>3</td> <td>Off</td> <td>00</td> <td>0</td> <td>Not used. Fixed to Off.</td> </tr> <tr> <td>4</td> <td>On</td> <td>10</td> <td>16</td> <td>Not used. Fixed to On.</td> </tr> <tr> <td rowspan="2">5</td> <td>Off</td> <td>00</td> <td>0</td> <td>No paper-end stop.</td> </tr> <tr> <td>On</td> <td>20</td> <td>32</td> <td>Printing stops due to paper end.</td> </tr> <tr> <td rowspan="2">6</td> <td>Off</td> <td>00</td> <td>0</td> <td>No error.</td> </tr> <tr> <td>On</td> <td>40</td> <td>64</td> <td>Error occurs.</td> </tr> <tr> <td>7</td> <td>Off</td> <td>00</td> <td>0</td> <td>Not used. Fixed to Off.</td> </tr> </tbody> </table>	Bit	On / Off	Hex	Decimal	Function	0	Off	00	0	Not used. Fixed to Off.	1	On	02	2	Not used. Fixed to On.	2	Off	00	0	Cover is closed.	On	04	4	Cover is open.	3	Off	00	0	Not used. Fixed to Off.	4	On	10	16	Not used. Fixed to On.	5	Off	00	0	No paper-end stop.	On	20	32	Printing stops due to paper end.	6	Off	00	0	No error.	On	40	64	Error occurs.	7	Off	00	0	Not used. Fixed to Off.
Bit	On / Off	Hex	Decimal	Function																																																					
0	Off	00	0	Not used. Fixed to Off.																																																					
1	On	02	2	Not used. Fixed to On.																																																					
2	Off	00	0	Cover is closed.																																																					
	On	04	4	Cover is open.																																																					
3	Off	00	0	Not used. Fixed to Off.																																																					
4	On	10	16	Not used. Fixed to On.																																																					
5	Off	00	0	No paper-end stop.																																																					
	On	20	32	Printing stops due to paper end.																																																					
6	Off	00	0	No error.																																																					
	On	40	64	Error occurs.																																																					
7	Off	00	0	Not used. Fixed to Off.																																																					
n = 3 : Error status																																																									
<table border="1"> <thead> <tr> <th>Bit</th> <th>On / Off</th> <th>Hex</th> <th>Decimal</th> <th>Function</th> </tr> </thead> <tbody> <tr> <td>0</td> <td>Off</td> <td>00</td> <td>0</td> <td>Not used. Fixed to Off.</td> </tr> <tr> <td>1</td> <td>On</td> <td>02</td> <td>2</td> <td>Not used. Fixed to On.</td> </tr> <tr> <td>2</td> <td>Off</td> <td>00</td> <td>0</td> <td>Not used. Fixed to Off.</td> </tr> </tbody> </table>	Bit	On / Off	Hex	Decimal	Function	0	Off	00	0	Not used. Fixed to Off.	1	On	02	2	Not used. Fixed to On.	2	Off	00	0	Not used. Fixed to Off.																																					
Bit	On / Off	Hex	Decimal	Function																																																					
0	Off	00	0	Not used. Fixed to Off.																																																					
1	On	02	2	Not used. Fixed to On.																																																					
2	Off	00	0	Not used. Fixed to Off.																																																					

3	Off	00	0	Not used. Fixed to Off.
4	On	10	16	Not used. Fixed to On.
5	Off	00	0	Not used. Fixed to Off.
6	Off	00	0	Not used. Fixed to Off.
7	Off	00	0	Not used. Fixed to Off.

n = 4 : Continuous paper sensor status.

Bit	On / Off	Hex	Decimal	Function
0	Off	00	0	Not used. Fixed to Off.
1	Off	02	2	Not used. Fixed to On.
2	Off	00	0	No paper-near-end stop.
	On	04	4	Printing stops due to paper near end.
3	Off	00	0	No paper-near-end stop.
	On	08	8	Printing stops due to paper near end.
4	On	10	16	Not used. Fixed to On.
5	Off	00	0	No paper-end stop.
	On	20	32	Printing stops due to paper end.
6	Off	00	0	No paper-end stop.
	On	40	64	Printing stops due to paper end.
7	Off	00	0	Not used. Fixed to Off.

DLE ENQ n

[Name]	Real-time request to printer.
[Format]	ASCII DLE ENQ n Hex. 10 05 n Decimal 16 5 n
[Range]	$1 \leq n \leq 2$
[Description]	Responds to requests n specifications from the host in real-time. n specifications are below. n = 1: Recover from the error and start printing from the line where the error occurred. n = 2: Recover from error after clearing the reception buffer and print buffer. This command is enabled even when the printer specification is disabled by ESC = (select peripheral devices).

DLE DC4 n m t

[Name]	Real-time output of specified pulse.
[Format]	ASCII DLE DC4 n m t Hex. 10 14 n m t Decimal 16 20 n m t
[Range]	n = 1 m = 0,1 1 ≤ t ≤ 8
[Description]	This outputs a signal specified by t to the connector pin specified by m. m = 0: #2 Pin of the drawer kick connector m = 1: #5 Pin of the drawer kick connector On time is set to t x 100 msec; Off time is set to t x 100 msec.

ESC FF

[Name]	Print data in page mode.
[Format]	ASCII ESC FF Hex. 1B 0C Decimal 27 12
[Range]	N/A
[Description]	Prints all buffered data in the print area collectively in page mode. <ul style="list-style-type: none"> ● This command is enabled only in page mode. ● Holds the following information after printing. <ol style="list-style-type: none"> a. Expanded data b. Character print direction selection in page mode (ESC T) c. Set print region (ESC W) in the page mode. d. Character expansion position

ESC SP n

[Name]	Set right-side character spacing.
[Format]	ASCII ESC SP n Hex. 1B 20 n Decimal 27 32 n
[Range]	0 ≤ n ≤ 255 Initial Value n = 0
[Description]	This command sets the size of space to right of character. Right space = n x [horizontal motion units].

ESC ! n

[Name]	Select print mode(s).																																																																	
[Format]	ASCII ESC ! n Hex. 1B 21 n Decimal 27 33 n																																																																	
[Range]	$0 \leq n \leq 255$ Initial Value n = 0																																																																	
[Description]	<p>This command selects print mode(s) with bits having following meanings.</p> <table border="1"> <thead> <tr> <th>Bit</th> <th>On / Off</th> <th>Hex</th> <th>Decimal</th> <th>Function</th> </tr> </thead> <tbody> <tr> <td rowspan="2">0</td> <td>Off</td> <td>00</td> <td>0</td> <td>Character font A selected.</td> </tr> <tr> <td>On</td> <td>01</td> <td>1</td> <td>Character font B selected.</td> </tr> <tr> <td>1</td> <td>Off</td> <td>00</td> <td>0</td> <td>Not used. Fixed to Off.</td> </tr> <tr> <td>2</td> <td>Off</td> <td>00</td> <td>0</td> <td>Not used. Fixed to Off.</td> </tr> <tr> <td rowspan="2">3</td> <td>Off</td> <td>00</td> <td>0</td> <td>Emphasized mode not selected.</td> </tr> <tr> <td>On</td> <td>08</td> <td>8</td> <td>Emphasized mode selected.</td> </tr> <tr> <td rowspan="2">4</td> <td>Off</td> <td>00</td> <td>0</td> <td>Double-height mode not selected</td> </tr> <tr> <td>On</td> <td>10</td> <td>16</td> <td>Double-height mode selected</td> </tr> <tr> <td rowspan="2">5</td> <td>Off</td> <td>00</td> <td>0</td> <td>Double-width mode not selected.</td> </tr> <tr> <td>On</td> <td>20</td> <td>32</td> <td>Double-width mode selected.</td> </tr> <tr> <td>6</td> <td>Off</td> <td>00</td> <td>0</td> <td>Not used. Fixed to Off.</td> </tr> <tr> <td rowspan="2">7</td> <td>Off</td> <td>00</td> <td>0</td> <td>Underline mode not selected.</td> </tr> <tr> <td>On</td> <td>80</td> <td>128</td> <td>Underline mode selected.</td> </tr> </tbody> </table>	Bit	On / Off	Hex	Decimal	Function	0	Off	00	0	Character font A selected.	On	01	1	Character font B selected.	1	Off	00	0	Not used. Fixed to Off.	2	Off	00	0	Not used. Fixed to Off.	3	Off	00	0	Emphasized mode not selected.	On	08	8	Emphasized mode selected.	4	Off	00	0	Double-height mode not selected	On	10	16	Double-height mode selected	5	Off	00	0	Double-width mode not selected.	On	20	32	Double-width mode selected.	6	Off	00	0	Not used. Fixed to Off.	7	Off	00	0	Underline mode not selected.	On	80	128	Underline mode selected.
Bit	On / Off	Hex	Decimal	Function																																																														
0	Off	00	0	Character font A selected.																																																														
	On	01	1	Character font B selected.																																																														
1	Off	00	0	Not used. Fixed to Off.																																																														
2	Off	00	0	Not used. Fixed to Off.																																																														
3	Off	00	0	Emphasized mode not selected.																																																														
	On	08	8	Emphasized mode selected.																																																														
4	Off	00	0	Double-height mode not selected																																																														
	On	10	16	Double-height mode selected																																																														
5	Off	00	0	Double-width mode not selected.																																																														
	On	20	32	Double-width mode selected.																																																														
6	Off	00	0	Not used. Fixed to Off.																																																														
7	Off	00	0	Underline mode not selected.																																																														
	On	80	128	Underline mode selected.																																																														

ESC \$ nL nH

[Name]	Set absolute print position.
[Format]	ASCII ESC \$ nL nH Hex. 1B 24 nL nH Decimal 27 36 nL nH
[Range]	$0 \leq (nL + nH \times 256) \leq 65535$ ($0 \leq nH \leq 255$, $0 \leq nL \leq 255$)
[Description]	This command specifies the next print starting position in reference to the left edge of the print area. The printing start position is calculated using $(nL + nH \times 256) \times$ (vertical or horizontal motion units). Specifications exceeding the print range are ignored.

ESC * m nL nH d1...dk

[Name]	Select bit image mode					
[Format]	ASCII ESC * m nL nH d1...dk Hex. 1B 2A m nL nH d1...dk Decimal 27 42 m nL nH d1...dk					
[Range]	m = 0,1,32,33 $0 \leq nL \leq 255$ $0 \leq nH \leq 3$ $0 \leq d \leq 255$					
[Description]	Selects a bit-image mode in mode <i>m</i> for the number of dots specified by <i>nL</i> and <i>nH</i> . m = 1,33 : (nL+nHx256)<576 (3 inch);(nL+nHx256)<432 (2 inch). m = 0,32 : (nL+nHx256)<288 (3 inch);(nL+nHx256)<216 (2 inch).					
	m	Mode	Number of Vert. Dir. Dots	Density of Vert. Dir. Dots	Density of Hor. Dir. Dots	Data Count (k)
	0	8 dot single density	8	67 DPI	101 DPI	nL+nHx256
	1	8 dot double density	8	67 DPI	203 DPI	nL+nHx256
	32	24 dot single density	24	203 DPI	101 DPI	(nL+nHx256) x3
33	24 dot double density	24	203 DPI	203 DPI	(nL+nHx256) x3	

ESC - n

[Name]	Turn underline mode on/off.								
[Format]	ASCII ESC - n Hex. 1B 2D n Decimal 27 45 n								
[Range]	0 ≤ n ≤ 2 Initial Value n = 0								
[Description]	<p>This command enables the print data following it to be printer out underlined. The underline mode varied depending on the following values of n:</p> <table border="1"> <thead> <tr> <th>n</th> <th>Function</th> </tr> </thead> <tbody> <tr> <td>0</td> <td>Turns off underline mode</td> </tr> <tr> <td>1</td> <td>Turns on underline mode, set at 1-dot thick</td> </tr> <tr> <td>2</td> <td>Turns on underline mode, set at 2-dot thick</td> </tr> </tbody> </table>	n	Function	0	Turns off underline mode	1	Turns on underline mode, set at 1-dot thick	2	Turns on underline mode, set at 2-dot thick
n	Function								
0	Turns off underline mode								
1	Turns on underline mode, set at 1-dot thick								
2	Turns on underline mode, set at 2-dot thick								

ESC 2

[Name]	Select default line spacing.
[Format]	ASCII ESC 2 Hex. 1B 32 Decimal 27 50
[Range]	N/A
[Description]	This command sets the default line spacing The default line spacing is approximately 4.25 mm, which is equivalent to 34 dots.

ESC 3 n

[Name]	Set line spacing.
[Format]	ASCII ESC 3 n Hex. 1B 33 n Decimal 27 51 n
[Range]	0 ≤ n ≤ 255 Initial Value n = 34
[Description]	<p>This command sets the line spacing using a following rule. Line spacing = n x (vertical or horizontal motion units)</p>

ESC = n

[Name]	Select peripheral device.			
[Format]	ASCII	ESC	=	n
	Hex.	1B	3D	n
	Decimal	27	61	n
[Range]	0 ≤ n ≤ 255 Initial Value n = 1			
[Description]	Selects the peripheral device for which the data is effective from the host computer.			
	Bit	Function	"0"	"1"
	7	Undefined		
	6	Undefined		
	5	Undefined		
	4	Undefined		
	3	Undefined		
	2	Undefined		
	1	Undefined		
	0	Printer	Invalid	Valid

ESC @

[Name]	Initialize printer.			
[Format]	ASCII	ESC	@	
	Hex.	1B	40	
	Decimal	27	64	
[Range]	N/A			
[Description]	Clears data from the print buffer and sets the printer to its default settings.			

ESC D n1...nk NUL

[Name]	Set horizontal tab position			
[Format]	ASCII	ESC	D	n1...nk NUL
	Hex.	1B	44	n1...nk NUL
	Decimal	27	68	n1...nk NUL
[Range]	1 ≤ n ≤ 255 0 ≤ k ≤ 32			
[Description]	Sets horizontal tab position			
	<ul style="list-style-type: none"> ● n specifies the column number for setting a horizontal tab position from the left margin or the beginning of the line. ● k indicates the number of horizontal tab positions to be set. 			

ESC E n

[Name]	Turn emphasized mode on / off.
[Format]	ASCII ESC E n Hex. 1B 45 n Decimal 27 69 n
[Range]	0 ≤ n ≤ 255 Initial Value n = 0
[Description]	This command turns emphasized mode on or off by toggling the least significant bit of n as followings: When the LSB of n is 0, the emphasized mode is turned off. When the LSB of n is 1, the emphasized mode is turned on.

ESC G n

[Name]	Turn double-strike mode on/off.
[Format]	ASCII ESC G n Hex. 1B 47 n Decimal 27 71 n
[Range]	0 ≤ n ≤ 255 Initial Value n = 0
[Description]	Specifies or cancels double printing. Cancels double printing when n = <*****0>B. Specifies double printing when n = <*****1>B. <ul style="list-style-type: none"> ● n is effective only when it is the lowest bit. ● This printer is not capable of double printing, so the print is the same as when using emphasized printing. ● This command is enabled for ANK characters

ESC J n

[Name]	Print and feed paper.
[Format]	ASCII ESC J n Hex. 1B 4A n Decimal 27 74 n
[Range]	0 ≤ n ≤ 255
[Description]	This command prints the data in the print buffer and feeds the paper [n X vertical motion unit]. <ul style="list-style-type: none"> ● Sets the print position to the beginning of the next line after printing. ● In standard mode, the printer uses the vertical motion unit (y). ● In page mode, this command functions as follows, depending on the starting position of the printable area: (1) When the starting position is set to the upper left or lower right of the printable area using ESC T, the vertical motion unit (y) is used.

	<p>(2) When the starting position is set to the upper right or lower left of the printable area using ESC T, the horizontal motion unit (x) is used.</p> <ul style="list-style-type: none"> ● The maximum line spacing is 150mm (5.9 inches). When the setting value exceeds the maximum, it is converted to the maximum automatically.
--	----------------------------------------------------------------------------------------------------------------------------------------------------------------------------------------------------------------------------------------------------------------------------------------------------------------------------------------------------------------

ESC L

[Name]	Select page mode
[Format]	ASCII ESC L Hex. 1B 4C Decimal 27 76
[Range]	N/A
[Description]	<ul style="list-style-type: none"> ● Enabled only when input with the top of line. ● Invalid when input by page mode. ● Returns to standard mode after the following commands are issued. <ol style="list-style-type: none"> a. FF (Print and recover to page mode) b. ESC S (Select standard mode) ● Character expansion position has the starting point specified by ESC T (Character print direction selection in page mode) in the printing region designated by the ESC W (Set print region in the page mode) command. ● This command switches the settings for the following commands the values of which can be set independently in standard mode and page mode to those for page mode <ol style="list-style-type: none"> a. Set space amount: ESC SP, FS S b. Set line feed amount: ESC 2, ESC 3 ● The following commands are enabled only when in page mode. <ol style="list-style-type: none"> a. ESC V : Specify/cancel character 90 degree clockwise rotation b. ESC a : Position alignment c. ESC { : Specify/cancel upside-down printing d. GS W : Set print region width ● The following command is ignored in page mode. <ol style="list-style-type: none"> a. GS (A : Test print ● The following commands are invalid in page mode. <ol style="list-style-type: none"> a. FS p : Print NV bit image b. FS q : Define NV bit image c. GS v 0 : Print raster bit images d. GS L : Set left margin ● Recover to standard mode using ESC @ (initialize printer).

ESC M n

[Name]	Select character font.						
[Format]	ASCII ESC M n Hex. 1B 4D n Decimal 27 77 n						
[Range]	n = 0, 1 Initial Value n = 0						
[Description]	This command selects ANK character fonts using n as follows: <table border="1" style="margin-left: 20px;"> <thead> <tr> <th>n</th> <th>Function</th> </tr> </thead> <tbody> <tr> <td>0</td> <td>Character font A selected</td> </tr> <tr> <td>1</td> <td>Character font B selected</td> </tr> </tbody> </table>	n	Function	0	Character font A selected	1	Character font B selected
n	Function						
0	Character font A selected						
1	Character font B selected						

ESC R n

[Name]	Select an international character set.																																		
[Format]	ASCII ESC R n Hex. 1B 52 n Decimal 27 82 n																																		
[Range]	0 ≤ n ≤ 16 Initial Value n = 0																																		
[Description]	This command specifies international characters according to n values. <table border="1" style="margin-left: 20px;"> <thead> <tr> <th>n</th> <th>Character Set</th> </tr> </thead> <tbody> <tr><td>0</td><td>USA</td></tr> <tr><td>1</td><td>France</td></tr> <tr><td>2</td><td>Germany</td></tr> <tr><td>3</td><td>UK</td></tr> <tr><td>4</td><td>Denmark I</td></tr> <tr><td>5</td><td>Sweden</td></tr> <tr><td>6</td><td>Italy</td></tr> <tr><td>7</td><td>Spain</td></tr> <tr><td>8</td><td>Japan</td></tr> <tr><td>9</td><td>Norway</td></tr> <tr><td>10</td><td>Denmark II</td></tr> <tr><td>11</td><td>Spain II</td></tr> <tr><td>12</td><td>Latin America</td></tr> <tr><td>13</td><td>Korea</td></tr> <tr><td>14</td><td>Russia</td></tr> <tr><td>15</td><td>Slavonic</td></tr> </tbody> </table>	n	Character Set	0	USA	1	France	2	Germany	3	UK	4	Denmark I	5	Sweden	6	Italy	7	Spain	8	Japan	9	Norway	10	Denmark II	11	Spain II	12	Latin America	13	Korea	14	Russia	15	Slavonic
n	Character Set																																		
0	USA																																		
1	France																																		
2	Germany																																		
3	UK																																		
4	Denmark I																																		
5	Sweden																																		
6	Italy																																		
7	Spain																																		
8	Japan																																		
9	Norway																																		
10	Denmark II																																		
11	Spain II																																		
12	Latin America																																		
13	Korea																																		
14	Russia																																		
15	Slavonic																																		

	16	User Define	
--	----	-------------	--

ESC S

[Name]	Select standard mode
[Format]	ASCII ESC S Hex. 1B 53 Decimal 27 83
[Range]	N/A
[Description]	<ul style="list-style-type: none"> ● Valid only when input by page mode. ● All buffer data in page mode is deleted. ● Sets the print position to the beginning of the next line after execution. ● The print area set by ESC W (Set print region in page mode) is reset to the default setting. ● This command switches the settings for the following commands the values of which can be set independently in standard mode and page mode to those for standard mode <ul style="list-style-type: none"> a. ESC SP :Set character right space amount b. FS S :Set Chinese character space amount c. ESC 2 :Set default line spacing d. ESC 3 :Set line spacing ● The following commands are effective only when in standard mode. <ul style="list-style-type: none"> a. ESC W :Set print region in page mode b. ESC T :Select character print direction in page mode ● The following commands are ignored in standard mode. <ul style="list-style-type: none"> a. GS \$:Specify absolute position for character vertical direction in page Mode b. GS \ :Specify relative position for character vertical direction in page mode ● Standard mode is selected when the power is turned on, the printer is reset or initialized (ESC @).

ESC T n

[Name]	Select print direction in page mode.															
[Format]	ASCII ESC T n Hex. 1B 54 n Decimal 27 84 n															
[Range]	$0 \leq n \leq 3, 48 \leq n \leq 51$ Initial Value n = 0															
[Description]	<p>Selects the character printing direction and starting point in page mode.</p> <table border="1"> <thead> <tr> <th>n</th> <th>Print Direction</th> <th>Starting Point</th> </tr> </thead> <tbody> <tr> <td>0, 48</td> <td>Left to Right</td> <td>Upper Left (A in the figure below)</td> </tr> <tr> <td>1, 49</td> <td>Bottom to Top</td> <td>Lower Left (B in the figure below)</td> </tr> <tr> <td>2, 50</td> <td>Right to Left</td> <td>Lower Right (C in the figure below)</td> </tr> <tr> <td>3, 51</td> <td>Top to Bottom</td> <td>Upper Right (D in the figure below)</td> </tr> </tbody> </table>	n	Print Direction	Starting Point	0, 48	Left to Right	Upper Left (A in the figure below)	1, 49	Bottom to Top	Lower Left (B in the figure below)	2, 50	Right to Left	Lower Right (C in the figure below)	3, 51	Top to Bottom	Upper Right (D in the figure below)
n	Print Direction	Starting Point														
0, 48	Left to Right	Upper Left (A in the figure below)														
1, 49	Bottom to Top	Lower Left (B in the figure below)														
2, 50	Right to Left	Lower Right (C in the figure below)														
3, 51	Top to Bottom	Upper Right (D in the figure below)														

ESC V n

[Name]	Turn 90 degree clockwise rotation mode on/off						
[Format]	ASCII ESC V n Hex. 1B 56 n Decimal 27 86 n						
[Range]	$0 \leq n \leq 1, 48 \leq n \leq 49$ Initial Value n = 0						
[Description]	<p>Specifies or cancels character 90 degree clockwise rotation.</p> <table border="1"> <thead> <tr> <th>n</th> <th>Function</th> </tr> </thead> <tbody> <tr> <td>0, 48</td> <td>Turns off 90 degree clockwise rotation mode</td> </tr> <tr> <td>1, 49</td> <td>Turns on 90 degree clockwise rotation mode</td> </tr> </tbody> </table> <ul style="list-style-type: none"> • Underlines are not applied to characters rotated 90 degrees clockwise even when ESC !,ESC - or FS - commands are given. • If 90 degree clockwise rotation is specified, double-wide and double-tall commands in the 90 rotation mode enlarges characters in the opposite 	n	Function	0, 48	Turns off 90 degree clockwise rotation mode	1, 49	Turns on 90 degree clockwise rotation mode
n	Function						
0, 48	Turns off 90 degree clockwise rotation mode						
1, 49	Turns on 90 degree clockwise rotation mode						

	<p>directions to double-wide and double-tall commands.</p> <ul style="list-style-type: none"> • This command only affects printing in standard mode. • In page mode, this command is only effective for the setting. • This command is effective for ANK and Chinese characters.
--	-------------------------------------------------------------------------------------------------------------------------------------------------------------------------------------------------------------------------------------------------------------------------------------------------------------------

ESC W xL xH yL yH dxL dxH dyL dyH

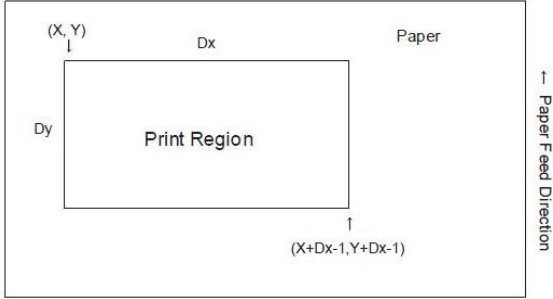
[Name]	Set printing area in page mode
[Format]	<p>ASCII ESC W xL xH yL yH dxL dxH dyL dyH</p> <p>Hex. 1B 57 xL xH yL yH dxL dxH dyL dyH</p> <p>Decimal 27 87 xL xH yL yH dxL dxH dyL dyH</p>
[Range]	<p>$0 \leq xL, xH, yL, yH, dxL, dxH, dyL, dyH \leq 255$</p> <p>However, this excludes $dxL = dxH = 0$ or $dyL = dyH = 0$</p> <p>Initial Value $xL = xH = yL = yH = 0$</p>
[Description]	<p>Sets the print region position and size.</p> <ul style="list-style-type: none"> • Horizontal direction starting point $[(xL + xH \times 256) \times \text{basic calculated pitch}]$ • Vertical direction starting point $[(yL + yH \times 256) \times \text{basic calculated pitch}]$ • Horizontal direction length $[(dxL + dxH \times 256) \text{ basic calculated pitch}]$ • Vertical direction length $[(dyL + dyH \times 256) \text{ basic calculated pitch}]$ • $(X+Dx-1) < 576$ (3 inch, basic calculated pitch=1); $(X+Dx-1) < 432$ (2 inch, basic calculated pitch=1) • $(Y+Dy-1) < 768$ (basic calculated pitch=1); • If (horizontal starting position + printing area width) exceeds the printable area, the printing area width is automatically set to (horizontal printable area - horizontal starting position). • If (vertical starting position + printing area height) exceeds the printable area, the printing area height is automatically set to (vertical printable area - vertical starting position). 

ESC \ nL nH

[Name]	Set relative print position.
[Format]	ASCII ESC \ nL nH Hex. 1B 5C nL nH Decimal 27 92 nL nH
[Range]	$0 \leq (nL + nH \times 256) \leq 65535$ ($0 \leq nL \leq 255, 0 \leq nH \leq 255$)
[Description]	Specifies the next print starting position with a relative position based on the current position. This sets the position from the current position to $[(nL + nH \times 256) \times \text{basic calculated pitch}]$ for the next print starting position. <ul style="list-style-type: none"> ● Specifications exceeding the print range are ignored..

ESC a n

[Name]	Select justification.								
[Format]	ASCII ESC a n Hex. 1B 61 n Decimal 27 97 n								
[Range]	$0 \leq n \leq 2$ Initial Value $n = 0$								
[Description]	This command specifies position alignment for all data in one line in standard mode, using n as follows: <table border="1" style="margin-left: 40px;"> <tr> <td>n</td> <td>Alignment</td> </tr> <tr> <td>0</td> <td>Left alignment</td> </tr> <tr> <td>1</td> <td>Center alignment</td> </tr> <tr> <td>2</td> <td>Right alignment</td> </tr> </table> <p>This command has no effect in page mode.</p>	n	Alignment	0	Left alignment	1	Center alignment	2	Right alignment
n	Alignment								
0	Left alignment								
1	Center alignment								
2	Right alignment								

ESC c 3 n

[Name]	Select paper sensor(s) to output paper-end signals.		
[Format]	ASCII	ESC	c 3 n
	Hex.	1B 63	33 n
	Decimal	27 99	51 n
[Range]	Specification: $0 \leq n \leq 3$ Initial Value n = 0		
[Description]	Selects paper out detector that outputs a paper out signal when paper has run out.		
	Bit	Function	"0" "1"
	7	Undefined	
	6	Undefined	
	5	Undefined	
	4	Undefined	
	3	Undefined	
	2	Undefined	
	1	Paper roll near end detector	Invalid Valid
	0	Paper roll near end detector	Invalid Valid

ESC c 4 n

[Name]	Select paper sensor(s) to stop printing.		
[Format]	ASCII	ESC	c 4 n
	Hex.	1B 63	34 n
	Decimal	27 99	52 n
[Range]	Specification: $0 \leq n \leq 3$ Initial Value n = 0		
[Description]	Selects the paper out detector to stop printing when paper has run out.		
	Bit	Function	"0" "1"
	7	Undefined	
	6	Undefined	
	5	Undefined	
	4	Undefined	
	3	Undefined	
	2	Undefined	
	1	Paper roll near end detector	Invalid Valid
	0	Paper roll near end detector	Invalid Valid

ESC c 5 n

[Name]	Enable/disable panel buttons
[Format]	ASCII ESC c 5 n Hex. 1B 63 35 n Decimal 27 99 53 n
[Range]	Specification: $0 \leq n \leq 255$ Initial Value n = 0
[Description]	Toggles the panel switches between enabled and disabled. <ul style="list-style-type: none"> ● Enables panel switches when n = <*****0>B. ● Disables panel switches when n = <*****1>B. ● n is effective only when it is the lowest bit. ● When disabled, all panel switches are disabled.

ESC d n

[Name]	Print and feed n lines
[Format]	ASCII ESC d n Hex. 1B 64 n Decimal 27 100 n
[Range]	$0 \leq n \leq 255$
[Description]	Prints the data in the print buffer and performs a paper feed of n lines. <ul style="list-style-type: none"> ● Sets the print position to the beginning of the next line after printing. ● Paper is fed approximately 150 mm if the [n x basic calculated pitch] exceeds approximately 150 mm (5.9 inches).

ESC i

[Name]	Full cut.
[Format]	ASCII ESC i Hex. 1B 69 Decimal 27 105
[Range]	N/A
[Description]	This command executes a full cut of the paper in standard mode

ESC m

[Name]	Partial cut.
[Format]	ASCII ESC m Hex. 1B 6D Decimal 27 109
[Range]	N/A
[Description]	This command executes a partial cut of the paper with one point uncut in standard mode.

ESC p m t1 t2

[Name]	General pulse.						
[Format]	ASCII ESC p m t1 t2 Hex. 1B 70 m t1 t2 Decimal 27 112 m t1 t2						
[Range]	$0 \leq m \leq 1, 48 \leq m \leq 49$ $0 \leq t1 \leq 255$ $0 \leq t2 \leq 255$						
[Description]	<p>This outputs a signal specified by t1 and t2 to the connector pin specified by m. Drawer kick on time is set to $t1 \times 2$ ms; off time is set to $t2 \times 2$ ms.</p> <table border="1"> <tr> <th>m</th> <th>Connector Pin</th> </tr> <tr> <td>0, 48</td> <td>Drawer kick connector pin #2</td> </tr> <tr> <td>1, 49</td> <td>Drawer kick connector pin #5</td> </tr> </table> <p>The diagram shows a pulse waveform. The pulse width is labeled t1, and the off-time (the interval from the end of the pulse to the start of the next pulse) is labeled t2.</p>	m	Connector Pin	0, 48	Drawer kick connector pin #2	1, 49	Drawer kick connector pin #5
m	Connector Pin						
0, 48	Drawer kick connector pin #2						
1, 49	Drawer kick connector pin #5						

ESC t n

[Name]	Select character code table.																				
[Format]	ASCII ESC t n Hex. 1B 74 n Decimal 27 116 n																				
[Range]	$0 \leq n \leq 8$ Initial Value n = 0																				
[Description]	<p>Select page n of the character code table.</p> <table border="1"> <thead> <tr> <th>n</th> <th>Character set</th> </tr> </thead> <tbody> <tr> <td>0</td> <td>CP-437</td> </tr> <tr> <td>1</td> <td>Katakana</td> </tr> <tr> <td>2</td> <td>CP-850</td> </tr> <tr> <td>3</td> <td>CP-852</td> </tr> <tr> <td>4</td> <td>CP-860</td> </tr> <tr> <td>5</td> <td>CP-863</td> </tr> <tr> <td>6</td> <td>CP-865</td> </tr> <tr> <td>7</td> <td>CP-1252</td> </tr> <tr> <td>8</td> <td>User Define</td> </tr> </tbody> </table>	n	Character set	0	CP-437	1	Katakana	2	CP-850	3	CP-852	4	CP-860	5	CP-863	6	CP-865	7	CP-1252	8	User Define
n	Character set																				
0	CP-437																				
1	Katakana																				
2	CP-850																				
3	CP-852																				
4	CP-860																				
5	CP-863																				
6	CP-865																				
7	CP-1252																				
8	User Define																				

ESC { n

[Name]	Turns upside-down printing mode on/off.												
[Format]	<table border="0"> <tr> <td>ASCII</td> <td>ESC</td> <td>{</td> <td>n</td> </tr> <tr> <td>Hex.</td> <td>1B</td> <td>7B</td> <td>n</td> </tr> <tr> <td>Decimal</td> <td>27</td> <td>123</td> <td>n</td> </tr> </table>	ASCII	ESC	{	n	Hex.	1B	7B	n	Decimal	27	123	n
ASCII	ESC	{	n										
Hex.	1B	7B	n										
Decimal	27	123	n										
[Range]	<p>$0 \leq n \leq 255$ Initial Value n = 0</p>												
[Description]	<p>Specifies or cancels upside-down printing.</p> <ul style="list-style-type: none"> ● Cancels upside-down printing when $n = \langle \text{*****}0 \rangle$. ● Specifies upside-down printing when $n = \langle \text{*****}1 \rangle$. ● n is effective only when it is the lowest bit. ● This command is effective only when input at the top of the line when standard mode is being used. ● This command has no effect in page mode. In page mode, this command is only effective for the setting. ● Upside-down printing rotates line data 180 degrees. <table border="1" style="margin-left: auto; margin-right: auto;"> <thead> <tr> <th>n</th> <th>Upside-down mode</th> </tr> </thead> <tbody> <tr> <td>0</td> <td>Turned off</td> </tr> <tr> <td>1</td> <td>Turned on</td> </tr> </tbody> </table>	n	Upside-down mode	0	Turned off	1	Turned on						
n	Upside-down mode												
0	Turned off												
1	Turned on												

FS p n m

[Name]	Print NV bit image.															
[Format]	<table border="0"> <tr> <td>ASCII</td> <td>FS</td> <td>p</td> <td>n</td> <td>m</td> </tr> <tr> <td>Hex.</td> <td>1C</td> <td>70</td> <td>n</td> <td>m</td> </tr> <tr> <td>Decimal</td> <td>28</td> <td>112</td> <td>n</td> <td>m</td> </tr> </table>	ASCII	FS	p	n	m	Hex.	1C	70	n	m	Decimal	28	112	n	m
ASCII	FS	p	n	m												
Hex.	1C	70	n	m												
Decimal	28	112	n	m												
[Range]	<p>$1 \leq n \leq 255$ $0 \leq m \leq 3, 48 \leq m \leq 51$</p>															
[Description]	<p>Prints NV bit image n using mode m.</p> <table border="1" style="margin-left: auto; margin-right: auto;"> <thead> <tr> <th>m</th> <th>Mode</th> </tr> </thead> <tbody> <tr> <td>0, 48</td> <td>Normal</td> </tr> <tr> <td>1, 49</td> <td>Double-width</td> </tr> <tr> <td>2, 50</td> <td>Double-height</td> </tr> <tr> <td>3, 51</td> <td>Quadruple</td> </tr> </tbody> </table> <ul style="list-style-type: none"> ● n specifies the NV bit image number. ● m specifies the bit-image mode. ● NV bit image is a bit image defined in non-volatile memory by FS q and printed by this command. ● This command is ignored when the specified NV bit image n is undefined. 	m	Mode	0, 48	Normal	1, 49	Double-width	2, 50	Double-height	3, 51	Quadruple					
m	Mode															
0, 48	Normal															
1, 49	Double-width															
2, 50	Double-height															
3, 51	Quadruple															

FS q n [xL xH yL yH d1...dk]1...[xL xH yL yH d1...dk]n

[Name]	Define NV bit image.
[Format]	ASCII FS q n [xL xH yL yH d1...dk]1...[xL xH yL yH d1...dk]n Hex. 1C 71 n [xL xH yL yH d1...dk]1...[xL xH yL yH d1...dk]n Decimal 28 113 n [xL xH yL yH d1...dk]1...[xL xH yL yH d1...dk]n
[Range]	$1 \leq n \leq 255$ $1 \leq (xL + xH \times 256) \leq 54$ ($0 \leq xL \leq 54, xH=0$) for 2 inch $1 \leq (xL + xH \times 256) \leq 72$ ($0 \leq xL \leq 72, xH=0$) for 3 inch $1 \leq (yL + yH \times 256) \leq 96$ ($0 \leq yL \leq 96, yH=0$) $0 \leq d \leq 255$ $k = (xL + xH \times 256) \times (yL + yH \times 256) \times 8$
[Description]	Defines the specified NV bit image. <ul style="list-style-type: none"> ● n specifies the number of NV bit images to define. ● xL and xH specify the horizontal direction for one NV bit image $(xL + xH \times 256) \times 8$ dots. ● yL and yH specify the vertical direction for one NV bit image $(yL + yH \times 256) \times 8$ dots. <div style="text-align: center;"> <p>For xL = 64, xH = 0, yL = 96, yH = 0</p> <p>$(xL + xH \times 256) \times 8 \text{ dots} = 512 \text{ dots}$</p> </div>

GS ! n

[Name]	Select character size.																																																																					
[Format]	<table border="0"> <tr> <td>ASCII</td> <td>GS</td> <td>!</td> <td>n</td> </tr> <tr> <td>Hex.</td> <td>1D</td> <td>21</td> <td>n</td> </tr> <tr> <td>Decimal</td> <td>29</td> <td>33</td> <td>n</td> </tr> </table>	ASCII	GS	!	n	Hex.	1D	21	n	Decimal	29	33	n																																																									
ASCII	GS	!	n																																																																			
Hex.	1D	21	n																																																																			
Decimal	29	33	n																																																																			
[Range]	<p>$0 \leq n \leq 255$ $(1 \leq \text{Vertical enlargement} \leq 8, 1 \leq \text{Horizontal enlargement} \leq 8)$ Initial Value $n = 0$</p>																																																																					
[Description]	<p>This command selects the character height and width using bits 0 to 3, and bits 4 to 7 respectively as follows:</p> <table border="1"> <thead> <tr> <th>Bit</th> <th>Function</th> <th>Setting</th> </tr> </thead> <tbody> <tr> <td>0</td> <td rowspan="4">Specifies the number of times normal font size in the vertical direction</td> <td rowspan="4">Refer to Table 2 [Enlarged in vertical direction]</td> </tr> <tr> <td>1</td> </tr> <tr> <td>2</td> </tr> <tr> <td>3</td> </tr> <tr> <td>4</td> <td rowspan="4">Specifies the number of times normal font size in the horizontal direction</td> <td rowspan="4">Refer to Table 1 [Enlarged in horizontal direction]</td> </tr> <tr> <td>5</td> </tr> <tr> <td>6</td> </tr> <tr> <td>7</td> </tr> </tbody> </table> <p>Table 1 [Enlarged in horizontal direction]</p> <table border="1"> <thead> <tr> <th>Hex</th> <th>Decimal</th> <th>Enlargement</th> </tr> </thead> <tbody> <tr> <td>00</td> <td>0</td> <td>1 time(standard)</td> </tr> <tr> <td>10</td> <td>16</td> <td>2 times</td> </tr> <tr> <td>20</td> <td>32</td> <td>3 times</td> </tr> <tr> <td>30</td> <td>48</td> <td>4 times</td> </tr> <tr> <td>40</td> <td>64</td> <td>5 times</td> </tr> <tr> <td>50</td> <td>80</td> <td>6 times</td> </tr> <tr> <td>60</td> <td>96</td> <td>7 times</td> </tr> <tr> <td>70</td> <td>112</td> <td>8 times</td> </tr> </tbody> </table> <p>Table 2 [Enlarged in vertical direction]</p> <table border="1"> <thead> <tr> <th>Hex</th> <th>Decimal</th> <th>Enlargement</th> </tr> </thead> <tbody> <tr> <td>00</td> <td>0</td> <td>1 time(standard)</td> </tr> <tr> <td>01</td> <td>1</td> <td>2 times</td> </tr> <tr> <td>02</td> <td>2</td> <td>3 times</td> </tr> <tr> <td>03</td> <td>3</td> <td>4 times</td> </tr> <tr> <td>04</td> <td>4</td> <td>5 times</td> </tr> <tr> <td>05</td> <td>5</td> <td>6 times</td> </tr> <tr> <td>06</td> <td>6</td> <td>7 times</td> </tr> <tr> <td>07</td> <td>7</td> <td>8 times</td> </tr> </tbody> </table>	Bit	Function	Setting	0	Specifies the number of times normal font size in the vertical direction	Refer to Table 2 [Enlarged in vertical direction]	1	2	3	4	Specifies the number of times normal font size in the horizontal direction	Refer to Table 1 [Enlarged in horizontal direction]	5	6	7	Hex	Decimal	Enlargement	00	0	1 time(standard)	10	16	2 times	20	32	3 times	30	48	4 times	40	64	5 times	50	80	6 times	60	96	7 times	70	112	8 times	Hex	Decimal	Enlargement	00	0	1 time(standard)	01	1	2 times	02	2	3 times	03	3	4 times	04	4	5 times	05	5	6 times	06	6	7 times	07	7	8 times
Bit	Function	Setting																																																																				
0	Specifies the number of times normal font size in the vertical direction	Refer to Table 2 [Enlarged in vertical direction]																																																																				
1																																																																						
2																																																																						
3																																																																						
4	Specifies the number of times normal font size in the horizontal direction	Refer to Table 1 [Enlarged in horizontal direction]																																																																				
5																																																																						
6																																																																						
7																																																																						
Hex	Decimal	Enlargement																																																																				
00	0	1 time(standard)																																																																				
10	16	2 times																																																																				
20	32	3 times																																																																				
30	48	4 times																																																																				
40	64	5 times																																																																				
50	80	6 times																																																																				
60	96	7 times																																																																				
70	112	8 times																																																																				
Hex	Decimal	Enlargement																																																																				
00	0	1 time(standard)																																																																				
01	1	2 times																																																																				
02	2	3 times																																																																				
03	3	4 times																																																																				
04	4	5 times																																																																				
05	5	6 times																																																																				
06	6	7 times																																																																				
07	7	8 times																																																																				

GS \$ nL nH

[Name]	Set absolute vertical print position in page mode
[Format]	ASCII GS \$ nL nH Hex. 1D 24 nL nH Decimal 29 36 nL nH
[Range]	0 ≤ nL ≤ 255, 0 ≤ nH ≤ 255,
[Description]	<p>Specifies the character vertical direction position for the data expansion starting position using the absolute position based on the starting point in page mode. The position of the character vertical direction for the next data expansion starting position is the position specified by [(nL + nH x 256) x basic calculated pitch] from the starting point.</p> <ul style="list-style-type: none"> ● When not in page mode, this command is ignored. ● Specifications for absolute positions that exceed the specified print range are ignored.

GS * X Y [d1...d(X x Y x 8)]

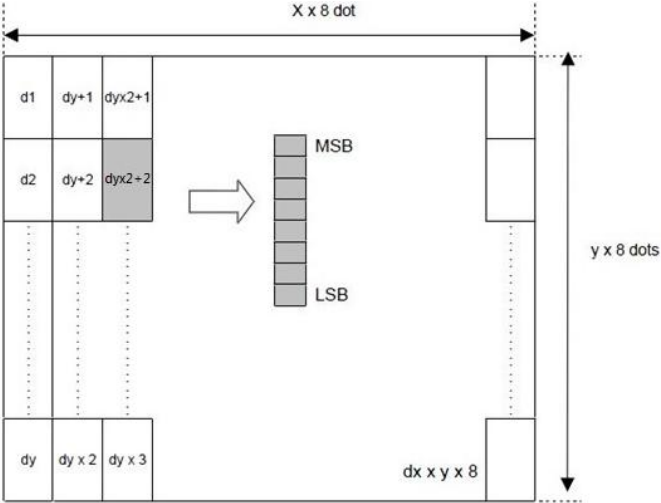
[Name]	Define download bit images.
[Format]	ASCII GS * X Y [d1...d(X x Y x 8)] Hex. 1D 2A X Y [d1...d(X x Y x 8)] Decimal 29 42 X Y [d1...d(X x Y x 8)]
[Range]	$1 \leq X \leq 54$ (for 2 inch) $1 \leq X \leq 72$ (for 3 inch) $1 \leq Y \leq 96$ $0 \leq d \leq 255$
[Description]	<p>Defines the download bit image of the number of dots specified by X and Y.</p> <ul style="list-style-type: none"> ● X specifies the number of bytes in the horizontal direction. ● Y specifies the number of bytes in the vertical direction. ● Horizontal direction dot count is X x 8 dots; Vertical direction dot count is Y x 8 dots ● d indicates the bit-image data. Bits that correspond to the dots to print are 1, and the bits that correspond to the dots that are not printed are 0. 

GS (A pL pH n m

[Name]	Execute test print.														
[Format]	<p>ASCII GS (A pL pH n m</p> <p>Hex. 1D 28 41 pL pH n m</p> <p>Decimal 29 40 65 pL pH n m</p>														
[Range]	<p>{pL+ (pH×256) } = 2 (pL = 2,pH = 0)</p> <p>0 ≤ n ≤ 2 , 48 ≤ n ≤ 50</p> <p>2 ≤ m ≤ 3 , 50 ≤ m ≤ 51</p>														
[Description]	<p>Executes the specified test print.</p> <p>The following command is ignored in page mode.</p> <p>Specifies the parameter count following pL and pH in (pL + (pH x 256)) bytes.</p> <p>n specifies the paper to be tested.</p> <table border="1"> <tr> <td>n</td> <td>Paper Type</td> </tr> <tr> <td>0 , 48</td> <td>Basic sheet (paper roll)</td> </tr> <tr> <td>1 , 49</td> <td>Paper Roll</td> </tr> <tr> <td>2 , 50</td> <td></td> </tr> </table> <p>m specifies a test pattern..</p> <table border="1"> <tr> <td>m</td> <td>Type of Test Print</td> </tr> <tr> <td>2 , 50</td> <td>Printer Status (Self Print)</td> </tr> <tr> <td>3 , 51</td> <td>Rolling Pattern Print</td> </tr> </table>	n	Paper Type	0 , 48	Basic sheet (paper roll)	1 , 49	Paper Roll	2 , 50		m	Type of Test Print	2 , 50	Printer Status (Self Print)	3 , 51	Rolling Pattern Print
n	Paper Type														
0 , 48	Basic sheet (paper roll)														
1 , 49	Paper Roll														
2 , 50															
m	Type of Test Print														
2 , 50	Printer Status (Self Print)														
3 , 51	Rolling Pattern Print														

GS (K pL pH n m

[Name]	Set print density.																												
[Format]	ASCII GS (A pL pH n m Hex. 1D 28 4B pL pH n m Decimal 29 40 75 pL pH n m																												
[Range]	{pL+ (pHx256) } = 2 (pL = 2,pH = 0) n = 49 250 ≤ m ≤ 255, 0 ≤ m ≤ 6 Initial Value m = 0																												
[Description]	Sets print density <table border="1"> <thead> <tr> <th>m</th> <th>Print Density</th> </tr> </thead> <tbody> <tr><td>250</td><td>0.7</td></tr> <tr><td>251</td><td>0.7</td></tr> <tr><td>252</td><td>0.8</td></tr> <tr><td>253</td><td>0.8</td></tr> <tr><td>254</td><td>0.9</td></tr> <tr><td>255</td><td>0.9</td></tr> <tr><td>0</td><td>1.0</td></tr> <tr><td>1</td><td>1.1</td></tr> <tr><td>2</td><td>1.1</td></tr> <tr><td>3</td><td>1.2</td></tr> <tr><td>4</td><td>1.2</td></tr> <tr><td>5</td><td>1.3</td></tr> <tr><td>6</td><td>1.3</td></tr> </tbody> </table>	m	Print Density	250	0.7	251	0.7	252	0.8	253	0.8	254	0.9	255	0.9	0	1.0	1	1.1	2	1.1	3	1.2	4	1.2	5	1.3	6	1.3
m	Print Density																												
250	0.7																												
251	0.7																												
252	0.8																												
253	0.8																												
254	0.9																												
255	0.9																												
0	1.0																												
1	1.1																												
2	1.1																												
3	1.2																												
4	1.2																												
5	1.3																												
6	1.3																												

GS / m

[Name]	Print downloaded bit image.																				
[Format]	ASCII GS / m Hex. 1D 2F m Decimal 29 47 m																				
[Range]	0 ≤ m ≤ 3, 48 ≤ m ≤ 51																				
[Description]	This command prints the downloaded bit image defined by GS * according to the mode denoted by m. <table border="1"> <thead> <tr> <th>m</th> <th>Mode</th> <th>Vertical dot density(DPI)</th> <th>Horizontal dot density(DPI)</th> </tr> </thead> <tbody> <tr><td>0 , 48</td><td>Normal</td><td>203</td><td>203</td></tr> <tr><td>1 , 49</td><td>Double-width</td><td>203</td><td>101</td></tr> <tr><td>2 , 50</td><td>Double-height</td><td>101</td><td>203</td></tr> <tr><td>3 , 51</td><td>Quadruple</td><td>101</td><td>101</td></tr> </tbody> </table>	m	Mode	Vertical dot density(DPI)	Horizontal dot density(DPI)	0 , 48	Normal	203	203	1 , 49	Double-width	203	101	2 , 50	Double-height	101	203	3 , 51	Quadruple	101	101
m	Mode	Vertical dot density(DPI)	Horizontal dot density(DPI)																		
0 , 48	Normal	203	203																		
1 , 49	Double-width	203	101																		
2 , 50	Double-height	101	203																		
3 , 51	Quadruple	101	101																		

GS B n

[Name]	Turn white/black reverse printing mode on/off
[Format]	ASCII GS B n Hex. 1D 42 n Decimal 29 66 n
[Range]	$0 \leq n \leq 255$ Initial Value n = 0
[Description]	<p>Specifies or cancels black and white inverted printing.</p> <ul style="list-style-type: none"> ● Cancels black and white inverted printing when $n = \langle \text{*****}0 \rangle B$. ● Specifies black and white inverted printing when $n = \langle \text{*****}1 \rangle B$. ● n is effective only when it is the lowest bit. ● Internal characters and download characters are targeted for black and white inverted printing. ● This command is effective for ANK and Chinese characters.

GS H n

[Name]	Select printing position of HRI characters.										
[Format]	ASCII GS H n Hex. 1D 48 n Decimal 29 72 n										
[Range]	$0 \leq n \leq 3, 48 \leq n \leq 51$ Initial Value n = 0										
[Description]	<p>Selects the printing position of HRI characters when printing bar codes.</p> <table border="1" style="width: 100%;"> <thead> <tr> <th style="width: 15%;">m</th> <th style="width: 85%;">Printing Position</th> </tr> </thead> <tbody> <tr> <td>0, 48</td> <td>No print</td> </tr> <tr> <td>1, 49</td> <td>Above bar code</td> </tr> <tr> <td>2, 50</td> <td>Below bar code</td> </tr> <tr> <td>3, 51</td> <td>Above and below bar code(both)</td> </tr> </tbody> </table>	m	Printing Position	0, 48	No print	1, 49	Above bar code	2, 50	Below bar code	3, 51	Above and below bar code(both)
m	Printing Position										
0, 48	No print										
1, 49	Above bar code										
2, 50	Below bar code										
3, 51	Above and below bar code(both)										

GS In

[Name]	Transmit printer ID.																												
[Format]	ASCII GS I n Hex. 1D 49 n Decimal 29 73 n																												
[Range]	$1 \leq n \leq 3, 49 \leq n \leq 51, 65 \leq n \leq 69$																												
[Description]	Transmits the printer ID specified by n as follows: <table border="1" style="margin-left: 20px;"> <thead> <tr> <th>n</th> <th>Printer ID Type</th> <th>Specifications</th> </tr> </thead> <tbody> <tr> <td>1, 49</td> <td>Model ID</td> <td>MB-1030 or MP-1060</td> </tr> <tr> <td>2, 50</td> <td>Type ID</td> <td>1030-XX or 1060-XX</td> </tr> <tr> <td>3, 51</td> <td>ROM Version ID</td> <td>Depends on the ROM version</td> </tr> <tr> <td>65</td> <td>Firmware Version</td> <td>Depends on the firmware version</td> </tr> <tr> <td>66</td> <td>Manufacturer Name</td> <td>MB-1030 System or MP-1060 System</td> </tr> <tr> <td>67</td> <td>Model Name</td> <td>MB-1030 or MP-1060</td> </tr> <tr> <td>68</td> <td>Serial Number</td> <td>Depends on the serial number</td> </tr> <tr> <td>69</td> <td>Chinese Character Types</td> <td> <u>Taiwan Language Characters:</u> TW_BIG5 <u>Japanese Language Characters:</u> JP_SJIS <u>Chinese Language Characters:</u> CN_GB2312 <u>Korean Language Characters:</u> KO_EUC-KR </td> </tr> </tbody> </table>		n	Printer ID Type	Specifications	1, 49	Model ID	MB-1030 or MP-1060	2, 50	Type ID	1030-XX or 1060-XX	3, 51	ROM Version ID	Depends on the ROM version	65	Firmware Version	Depends on the firmware version	66	Manufacturer Name	MB-1030 System or MP-1060 System	67	Model Name	MB-1030 or MP-1060	68	Serial Number	Depends on the serial number	69	Chinese Character Types	<u>Taiwan Language Characters:</u> TW_BIG5 <u>Japanese Language Characters:</u> JP_SJIS <u>Chinese Language Characters:</u> CN_GB2312 <u>Korean Language Characters:</u> KO_EUC-KR
n	Printer ID Type	Specifications																											
1, 49	Model ID	MB-1030 or MP-1060																											
2, 50	Type ID	1030-XX or 1060-XX																											
3, 51	ROM Version ID	Depends on the ROM version																											
65	Firmware Version	Depends on the firmware version																											
66	Manufacturer Name	MB-1030 System or MP-1060 System																											
67	Model Name	MB-1030 or MP-1060																											
68	Serial Number	Depends on the serial number																											
69	Chinese Character Types	<u>Taiwan Language Characters:</u> TW_BIG5 <u>Japanese Language Characters:</u> JP_SJIS <u>Chinese Language Characters:</u> CN_GB2312 <u>Korean Language Characters:</u> KO_EUC-KR																											

GS L nL nH

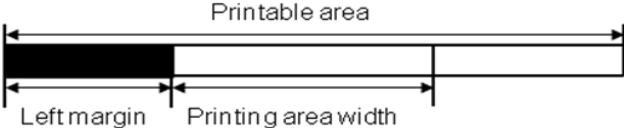
[Name]	Set left margin.	
[Format]	ASCII GS L nL nH Hex. 1D 4C nL nH Decimal 29 76 nL nH	
[Range]	$0 \leq nL \leq 255, 0 \leq nH \leq 255$ Initial Value ($nL + nH \times 256$)=0 ($nL=0, nH=0$)	
[Description]	<p>nL and nH set the specified left margin. The left margin is $[(nL + nH \times 256) \times \text{basic calculated pitch}]$.</p> 	

GS P x y

[Name]	Set basic calculated pitch.
[Format]	ASCII GS P x y Hex. 1D 50 x y Decimal 29 80 x y
[Range]	0 ≤ x ≤ 255 0 ≤ y ≤ 255 Initial Value x = 203, y = 203: EPSON targeted model print head 203 DPI
[Description]	Sets the horizontal basic calculated pitch to approximately 25.4/xmm [(1/x) inch], and the vertical basic calculated pitch to approximately 25.4/y (1/y) inch. x = 0: Returns the horizontal basic calculated pitch to its default value. y = 0: Returns the vertical basic calculated pitch to its default value.

GS V m

[Name]	Cut paper.										
[Format]	ASCII GS V m (n) Hex. 1D 56 m (n) Decimal 29 86 m (n)										
[Range]	m = 0,1,48,49,65,66 0 ≤ n ≤ 255										
[Description]	Executes specified paper cut. <table border="1" style="margin-left: 20px;"> <thead> <tr> <th>m</th> <th>Function</th> </tr> </thead> <tbody> <tr> <td>0 , 48</td> <td>Full cut</td> </tr> <tr> <td>1 , 49</td> <td>Partial cut (one point uncut)</td> </tr> <tr> <td>65</td> <td>Feeds paper to (cutting position + [n x basic calculated pitch]) and performs a full cut</td> </tr> <tr> <td>66</td> <td>Feeds paper to (cutting position + [n x basic calculated pitch]) and performs a partial cut (one point uncut)</td> </tr> </tbody> </table>	m	Function	0 , 48	Full cut	1 , 49	Partial cut (one point uncut)	65	Feeds paper to (cutting position + [n x basic calculated pitch]) and performs a full cut	66	Feeds paper to (cutting position + [n x basic calculated pitch]) and performs a partial cut (one point uncut)
m	Function										
0 , 48	Full cut										
1 , 49	Partial cut (one point uncut)										
65	Feeds paper to (cutting position + [n x basic calculated pitch]) and performs a full cut										
66	Feeds paper to (cutting position + [n x basic calculated pitch]) and performs a partial cut (one point uncut)										

GS W nL nH

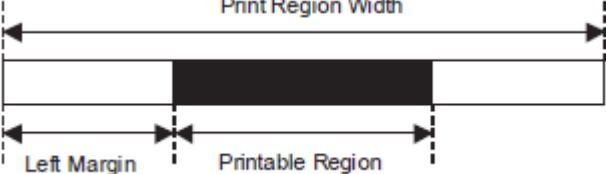
[Name]	Set printing area width.
[Format]	ASCII GS W nL nH Hex. 1D 57 nL nH Decimal 29 87 nL nH
[Range]	$0 \leq nL \leq 255, 0 \leq nH \leq 255$
[Description]	<ul style="list-style-type: none"> ● Sets the print region width specified by nL and nH. ● Print region width is $[(nL + nH \times 256) \times \text{basic calculated pitch}]$. ● $[(nL + nH \times 256) \times \text{basic calculated pitch}] \geq 24$. 

GS \ nL nH

[Name]	Set relative vertical print position in page mode.
[Format]	ASCII GS \ nL nH Hex. 1D 5C nL nH Decimal 29 92 nL nH
[Range]	$0 \leq nL \leq 255$ $0 \leq nH \leq 255$
[Description]	<p>Specifies the character vertical direction position for the data expansion starting position using the relative position based on the current point in page mode. This sets the position moved from the current position to $[(nL + nH \times 256) \times \text{basic calculated pitch}]$ for the next data expanding starting position.</p> <ul style="list-style-type: none"> ● When not in page mode, this command is ignored.

GS a n

[Name]	Enable/disable Automatic Status Back (ASB).																																																																																																	
[Format]	ASCII GS a n Hex. 1D 61 n Decimal 29 97 n																																																																																																	
[Range]	0 ≤ n ≤ 255 Initial Value n = 0																																																																																																	
[Description]	<p>Selects the statuses that are targeted for transmission with the automatic status function (ASB: Automatic Status Back).</p> <table border="1"> <thead> <tr> <th>Bits</th> <th>Statuses Targeted for ASB</th> <th>"0"</th> <th>"1"</th> </tr> </thead> <tbody> <tr> <td>7</td> <td>Undefined</td> <td>---</td> <td>---</td> </tr> <tr> <td>6</td> <td>Undefined</td> <td>---</td> <td>---</td> </tr> <tr> <td>5</td> <td>Undefined</td> <td>---</td> <td>---</td> </tr> <tr> <td>4</td> <td>Undefined</td> <td>---</td> <td>---</td> </tr> <tr> <td>3</td> <td>Continuous Paper Detector</td> <td>Invalid</td> <td>Valid</td> </tr> <tr> <td>2</td> <td>Error</td> <td>Invalid</td> <td>Valid</td> </tr> <tr> <td>1</td> <td>ONLINE/OFFLINE Status</td> <td>Invalid</td> <td>Valid</td> </tr> <tr> <td>0</td> <td>Drawer kick connector pin #3</td> <td>Invalid</td> <td>Valid</td> </tr> </tbody> </table> <p>The printer information transmitted is comprised of 4 bytes as follows: First byte(printer information)</p> <table border="1"> <thead> <tr> <th>Bit</th> <th>Off/On</th> <th>Hex</th> <th>Decimal</th> <th>Function</th> </tr> </thead> <tbody> <tr> <td>7</td> <td>Off</td> <td>00</td> <td>0</td> <td>Not used. Fixed to Off</td> </tr> <tr> <td rowspan="2">6</td> <td>Off</td> <td>00</td> <td>0</td> <td>Paper is not being fed by the paper feed button</td> </tr> <tr> <td>On</td> <td>40</td> <td>64</td> <td>Paper is being fed by the paper feed button</td> </tr> <tr> <td rowspan="2">5</td> <td>Off</td> <td>00</td> <td>0</td> <td>Cover is close</td> </tr> <tr> <td>On</td> <td>20</td> <td>32</td> <td>Cover is open</td> </tr> <tr> <td>4</td> <td>On</td> <td>10</td> <td>16</td> <td>Not used. Fixed to On</td> </tr> <tr> <td rowspan="2">3</td> <td>Off</td> <td>00</td> <td>0</td> <td>On-line</td> </tr> <tr> <td>On</td> <td>08</td> <td>8</td> <td>Off-line</td> </tr> <tr> <td rowspan="2">2</td> <td>Off</td> <td>00</td> <td>0</td> <td>Drawer kick-out connector pin 3 is LOW</td> </tr> <tr> <td>On</td> <td>04</td> <td>4</td> <td>Drawer kick-out connector pin 3 is HIGH</td> </tr> <tr> <td>1</td> <td>Off</td> <td>00</td> <td>0</td> <td>Not used. Fixed to Off</td> </tr> <tr> <td>0</td> <td>Off</td> <td>00</td> <td>0</td> <td>Not used. Fixed to Off</td> </tr> </tbody> </table>	Bits	Statuses Targeted for ASB	"0"	"1"	7	Undefined	---	---	6	Undefined	---	---	5	Undefined	---	---	4	Undefined	---	---	3	Continuous Paper Detector	Invalid	Valid	2	Error	Invalid	Valid	1	ONLINE/OFFLINE Status	Invalid	Valid	0	Drawer kick connector pin #3	Invalid	Valid	Bit	Off/On	Hex	Decimal	Function	7	Off	00	0	Not used. Fixed to Off	6	Off	00	0	Paper is not being fed by the paper feed button	On	40	64	Paper is being fed by the paper feed button	5	Off	00	0	Cover is close	On	20	32	Cover is open	4	On	10	16	Not used. Fixed to On	3	Off	00	0	On-line	On	08	8	Off-line	2	Off	00	0	Drawer kick-out connector pin 3 is LOW	On	04	4	Drawer kick-out connector pin 3 is HIGH	1	Off	00	0	Not used. Fixed to Off	0	Off	00	0	Not used. Fixed to Off
Bits	Statuses Targeted for ASB	"0"	"1"																																																																																															
7	Undefined	---	---																																																																																															
6	Undefined	---	---																																																																																															
5	Undefined	---	---																																																																																															
4	Undefined	---	---																																																																																															
3	Continuous Paper Detector	Invalid	Valid																																																																																															
2	Error	Invalid	Valid																																																																																															
1	ONLINE/OFFLINE Status	Invalid	Valid																																																																																															
0	Drawer kick connector pin #3	Invalid	Valid																																																																																															
Bit	Off/On	Hex	Decimal	Function																																																																																														
7	Off	00	0	Not used. Fixed to Off																																																																																														
6	Off	00	0	Paper is not being fed by the paper feed button																																																																																														
	On	40	64	Paper is being fed by the paper feed button																																																																																														
5	Off	00	0	Cover is close																																																																																														
	On	20	32	Cover is open																																																																																														
4	On	10	16	Not used. Fixed to On																																																																																														
3	Off	00	0	On-line																																																																																														
	On	08	8	Off-line																																																																																														
2	Off	00	0	Drawer kick-out connector pin 3 is LOW																																																																																														
	On	04	4	Drawer kick-out connector pin 3 is HIGH																																																																																														
1	Off	00	0	Not used. Fixed to Off																																																																																														
0	Off	00	0	Not used. Fixed to Off																																																																																														

Second byte (printer information)

Bit	Off/On	Hex	Decimal	Function
7	Off	00	0	Not used. Fixed to Off
6	Off	00	0	Not used. Fixed to Off
5	Off	00	0	Not used. Fixed to Off
4	Off	00	0	Not used. Fixed to Off
3	On	08	8	Not used. Fixed to Off
2	On	04	4	Not used. Fixed to Off
1	On	02	2	Not used. Fixed to Off
0	On	01	1	Not used. Fixed to Off

Third byte (paper sensor information)

Bit	Off/On	Hex	Decimal	Function
7	Off	00	0	Not used. Fixed to Off
6	Off	00	0	Not used. Fixed to Off
5	Off	00	0	Not used. Fixed to Off
4	On	00	0	Not used. Fixed to Off
2,3	Off	00	0	Paper end sensor: paper present
	On	0C	12	Paper end sensor: no paper present
0,1	Off	00	0	Paper near end sensor: paper adequate
	On	03	3	Paper near end sensor: paper near end

Fourth byte (paper sensor information)

Bit	Off/On	Hex	Decimal	Function
7	Off	00	0	Not used. Fixed to Off
6	Off	00	0	Black mark sensor status
5	Off	00	0	Not used. Fixed to Off
4	Off	00	0	Not used. Fixed to Off
3	On	08	8	Not used. Fixed to On
2	On	04	4	Not used. Fixed to On
1	On	02	2	Not used. Fixed to On
0	On	01	1	Not used. Fixed to On

GS f n

[Name]	Select font for HRI characters.							
[Format]	ASCII GS f n Hex. 1D 66 n Decimal 29 102 n							
[Range]	n = 0,1,48,49 Initial Value n = 0							
[Description]	Selects the HRI character font when printing bar codes. <table border="1" data-bbox="333 439 810 538"> <thead> <tr> <th>n</th> <th>Font</th> </tr> </thead> <tbody> <tr> <td>0, 48</td> <td>Selects Font A (12 x 24).</td> </tr> <tr> <td>1, 49</td> <td>Selects Font B (9 x 17).</td> </tr> </tbody> </table>		n	Font	0, 48	Selects Font A (12 x 24).	1, 49	Selects Font B (9 x 17).
n	Font							
0, 48	Selects Font A (12 x 24).							
1, 49	Selects Font B (9 x 17).							

GS h n

[Name]	Set bar code height.	
[Format]	ASCII GS h n Hex. 1D 68 n Decimal 29 104 n	
[Range]	1 ≤ n ≤ 255 Initial Value n = 162	
[Description]	Sets bar code height to n dots.	

GS k m d1 ... dk NUL.
GS k m n d1 ... dk

[Name]	Print bar code.																																																																								
[Format]	<p>1. ASCII GS k m d1...dk NUL Hex. 1D 6B m d1...dk NUL Decimal 29 107 m d1...dk NUL</p> <p>2. ASCII GS k m n d1... dk Hex. 1D 6B m n d1... dk Decimal 29 107 m n d1... dk</p>																																																																								
[Range]	<p>1. $0 \leq m \leq 6$ The definition region of k and d differ according to the bar code type.</p> <p>2. $65 \leq m \leq 73$ The definition region of n and d differ according to the bar code type.</p>																																																																								
[Description]	<p>Selects the bar code type and prints bar codes.</p> <p>1:</p> <table border="1"> <thead> <tr> <th>m</th> <th>Bar Code Type</th> <th>Defined region of k</th> <th>Defined region of d</th> </tr> </thead> <tbody> <tr> <td>0</td> <td>UPC-A</td> <td>$11 \leq k \leq 12$</td> <td>$48 \leq d \leq 57$</td> </tr> <tr> <td>1</td> <td>UPC-E</td> <td>$11 \leq k \leq 12$</td> <td>$48 \leq d \leq 57$</td> </tr> <tr> <td>2</td> <td>JAN13 (EAN13)</td> <td>$12 \leq k \leq 13$</td> <td>$48 \leq d \leq 57$</td> </tr> <tr> <td>3</td> <td>JAN8 (EAN8)</td> <td>$7 \leq k \leq 8$</td> <td>$48 \leq d \leq 57$</td> </tr> <tr> <td>4</td> <td>CODE39</td> <td>$1 \leq k \leq 255$</td> <td>$48 \leq d \leq 57, 65 \leq d \leq 90, 32, 36, 37, 43, 45, 46, 47$</td> </tr> <tr> <td>5</td> <td>ITF</td> <td>$2 \leq k \leq 254$ (However, This is an even number.)</td> <td>$48 \leq d \leq 57$</td> </tr> <tr> <td>6</td> <td>CODABAR</td> <td>$1 \leq k \leq 255$</td> <td>$48 \leq d \leq 57, 65 \leq d \leq 68, 36, 43, 45, 46, 47, 58$</td> </tr> </tbody> </table> <p>2:</p> <table border="1"> <thead> <tr> <th>m</th> <th>Bar Code Type</th> <th>Defined region of n</th> <th>Defined region of d</th> </tr> </thead> <tbody> <tr> <td>65</td> <td>UPC-A</td> <td>$11 \leq n \leq 12$</td> <td>$48 \leq d \leq 57$</td> </tr> <tr> <td>66</td> <td>UPC-E</td> <td>$11 \leq n \leq 12$</td> <td>$48 \leq d \leq 57$</td> </tr> <tr> <td>67</td> <td>JAN13 (EAN13)</td> <td>$12 \leq n \leq 13$</td> <td>$48 \leq d \leq 57$</td> </tr> <tr> <td>68</td> <td>JAN8 (EAN8)</td> <td>$7 \leq n \leq 8$</td> <td>$48 \leq d \leq 57$</td> </tr> <tr> <td>69</td> <td>CODE39</td> <td>$1 \leq n \leq 255$</td> <td>$48 \leq d \leq 57, 65 \leq d \leq 90, 32, 36, 37, 43, 45, 46, 47$</td> </tr> <tr> <td>70</td> <td>ITF</td> <td>$2 \leq n \leq 254$ (However, this is an even number.)</td> <td>$48 \leq d \leq 57$</td> </tr> <tr> <td>71</td> <td>CODABAR</td> <td>$1 \leq n \leq 255$</td> <td>$48 \leq d \leq 57, 65 \leq d \leq 68, 36, 43, 45, 46, 47, 58$</td> </tr> <tr> <td>72</td> <td>CODE93</td> <td>$1 \leq n \leq 255$</td> <td>$0 \leq d \leq 127$</td> </tr> <tr> <td>73</td> <td>CODE128</td> <td>$2 \leq n \leq 255$</td> <td>$0 \leq d \leq 127$</td> </tr> </tbody> </table>	m	Bar Code Type	Defined region of k	Defined region of d	0	UPC-A	$11 \leq k \leq 12$	$48 \leq d \leq 57$	1	UPC-E	$11 \leq k \leq 12$	$48 \leq d \leq 57$	2	JAN13 (EAN13)	$12 \leq k \leq 13$	$48 \leq d \leq 57$	3	JAN8 (EAN8)	$7 \leq k \leq 8$	$48 \leq d \leq 57$	4	CODE39	$1 \leq k \leq 255$	$48 \leq d \leq 57, 65 \leq d \leq 90, 32, 36, 37, 43, 45, 46, 47$	5	ITF	$2 \leq k \leq 254$ (However, This is an even number.)	$48 \leq d \leq 57$	6	CODABAR	$1 \leq k \leq 255$	$48 \leq d \leq 57, 65 \leq d \leq 68, 36, 43, 45, 46, 47, 58$	m	Bar Code Type	Defined region of n	Defined region of d	65	UPC-A	$11 \leq n \leq 12$	$48 \leq d \leq 57$	66	UPC-E	$11 \leq n \leq 12$	$48 \leq d \leq 57$	67	JAN13 (EAN13)	$12 \leq n \leq 13$	$48 \leq d \leq 57$	68	JAN8 (EAN8)	$7 \leq n \leq 8$	$48 \leq d \leq 57$	69	CODE39	$1 \leq n \leq 255$	$48 \leq d \leq 57, 65 \leq d \leq 90, 32, 36, 37, 43, 45, 46, 47$	70	ITF	$2 \leq n \leq 254$ (However, this is an even number.)	$48 \leq d \leq 57$	71	CODABAR	$1 \leq n \leq 255$	$48 \leq d \leq 57, 65 \leq d \leq 68, 36, 43, 45, 46, 47, 58$	72	CODE93	$1 \leq n \leq 255$	$0 \leq d \leq 127$	73	CODE128	$2 \leq n \leq 255$	$0 \leq d \leq 127$
m	Bar Code Type	Defined region of k	Defined region of d																																																																						
0	UPC-A	$11 \leq k \leq 12$	$48 \leq d \leq 57$																																																																						
1	UPC-E	$11 \leq k \leq 12$	$48 \leq d \leq 57$																																																																						
2	JAN13 (EAN13)	$12 \leq k \leq 13$	$48 \leq d \leq 57$																																																																						
3	JAN8 (EAN8)	$7 \leq k \leq 8$	$48 \leq d \leq 57$																																																																						
4	CODE39	$1 \leq k \leq 255$	$48 \leq d \leq 57, 65 \leq d \leq 90, 32, 36, 37, 43, 45, 46, 47$																																																																						
5	ITF	$2 \leq k \leq 254$ (However, This is an even number.)	$48 \leq d \leq 57$																																																																						
6	CODABAR	$1 \leq k \leq 255$	$48 \leq d \leq 57, 65 \leq d \leq 68, 36, 43, 45, 46, 47, 58$																																																																						
m	Bar Code Type	Defined region of n	Defined region of d																																																																						
65	UPC-A	$11 \leq n \leq 12$	$48 \leq d \leq 57$																																																																						
66	UPC-E	$11 \leq n \leq 12$	$48 \leq d \leq 57$																																																																						
67	JAN13 (EAN13)	$12 \leq n \leq 13$	$48 \leq d \leq 57$																																																																						
68	JAN8 (EAN8)	$7 \leq n \leq 8$	$48 \leq d \leq 57$																																																																						
69	CODE39	$1 \leq n \leq 255$	$48 \leq d \leq 57, 65 \leq d \leq 90, 32, 36, 37, 43, 45, 46, 47$																																																																						
70	ITF	$2 \leq n \leq 254$ (However, this is an even number.)	$48 \leq d \leq 57$																																																																						
71	CODABAR	$1 \leq n \leq 255$	$48 \leq d \leq 57, 65 \leq d \leq 68, 36, 43, 45, 46, 47, 58$																																																																						
72	CODE93	$1 \leq n \leq 255$	$0 \leq d \leq 127$																																																																						
73	CODE128	$2 \leq n \leq 255$	$0 \leq d \leq 127$																																																																						

GS r n

[Name]	Transmit status.																																																																										
[Format]	ASCII	GS	r n																																																																								
	Hex.	1D	72 n																																																																								
	Decimal	29	114 n																																																																								
[Range]	n = 1, 2, 49, 50																																																																										
[Description]	<p>Sends the specified status. Detector Status (n=1,49)</p> <table border="1"> <thead> <tr> <th>Bit</th> <th>Status</th> <th>"0"</th> <th>"1"</th> </tr> </thead> <tbody> <tr> <td>7</td> <td>Fixed at 0</td> <td></td> <td></td> </tr> <tr> <td>6</td> <td>Undefined</td> <td></td> <td></td> </tr> <tr> <td>5</td> <td>Undefined</td> <td></td> <td></td> </tr> <tr> <td>4</td> <td>Fixed at 0</td> <td></td> <td></td> </tr> <tr> <td>3</td> <td>Paper roll end detector</td> <td>Has Paper</td> <td>Paper out</td> </tr> <tr> <td>2</td> <td>Paper roll end detector</td> <td>Has Paper</td> <td>Paper out</td> </tr> <tr> <td>1</td> <td>Paper roll near end detector</td> <td>Has Paper</td> <td>Paper out</td> </tr> <tr> <td>0</td> <td>Paper roll near end detector</td> <td>Has Paper</td> <td>Paper out</td> </tr> </tbody> </table> <p>Drawer Kick Connector Status (n=2,50)</p> <table border="1"> <thead> <tr> <th>Bit</th> <th>Status</th> <th>"0"</th> <th>"1"</th> </tr> </thead> <tbody> <tr> <td>7</td> <td>Fixed at 0</td> <td></td> <td></td> </tr> <tr> <td>6</td> <td>Undefined</td> <td></td> <td></td> </tr> <tr> <td>5</td> <td>Undefined</td> <td></td> <td></td> </tr> <tr> <td>4</td> <td>Fixed at 0</td> <td></td> <td></td> </tr> <tr> <td>3</td> <td>Undefined</td> <td></td> <td></td> </tr> <tr> <td>2</td> <td>Undefined</td> <td></td> <td></td> </tr> <tr> <td>1</td> <td>Undefined</td> <td></td> <td></td> </tr> <tr> <td>0</td> <td>Drawer kick connector pin #3</td> <td>"L"</td> <td>"H"</td> </tr> </tbody> </table>			Bit	Status	"0"	"1"	7	Fixed at 0			6	Undefined			5	Undefined			4	Fixed at 0			3	Paper roll end detector	Has Paper	Paper out	2	Paper roll end detector	Has Paper	Paper out	1	Paper roll near end detector	Has Paper	Paper out	0	Paper roll near end detector	Has Paper	Paper out	Bit	Status	"0"	"1"	7	Fixed at 0			6	Undefined			5	Undefined			4	Fixed at 0			3	Undefined			2	Undefined			1	Undefined			0	Drawer kick connector pin #3	"L"	"H"
Bit	Status	"0"	"1"																																																																								
7	Fixed at 0																																																																										
6	Undefined																																																																										
5	Undefined																																																																										
4	Fixed at 0																																																																										
3	Paper roll end detector	Has Paper	Paper out																																																																								
2	Paper roll end detector	Has Paper	Paper out																																																																								
1	Paper roll near end detector	Has Paper	Paper out																																																																								
0	Paper roll near end detector	Has Paper	Paper out																																																																								
Bit	Status	"0"	"1"																																																																								
7	Fixed at 0																																																																										
6	Undefined																																																																										
5	Undefined																																																																										
4	Fixed at 0																																																																										
3	Undefined																																																																										
2	Undefined																																																																										
1	Undefined																																																																										
0	Drawer kick connector pin #3	"L"	"H"																																																																								

GS v 0 m xL xH yL yH d1 ... dk

[Name]	Print raster bit image.									
[Format]	ASCII	GS	v	0	m	xL	xH	yL	yH	d1...dk
	Hex.	1D	76	30	m	xL	xH	yL	yH	d1...dk
	Decimal	29	118	48	m	xL	xH	yL	yH	d1...dk
[Range]	m = 0, m = 48 0 ≤ xL ≤ 54(for 2 inch) 0 ≤ xL ≤ 72(for 3 inch) 0 ≤ xH ≤ 0 0 ≤ yL ≤ 255 0 ≤ yH ≤ 3 0 ≤ d ≤ 255 $k = (xL+xH \times 256) \times (yL+yH \times 256)$ However, $k \neq 0$									
[Description]	Prints raster method bit images using mode m.									
	m	Mode	Density of Vert. Dir. Dots				Density of Hor. Dir. Dots			
	0, 48	Normal Mode	203 DPI				203 DPI			
	<ul style="list-style-type: none"> • xL and xH specify the horizontal direction data count for one bit image (xL + xH x 256) in bytes. • yL and yH specify the vertical direction data count for one bit image (yL + yH x 256) in bytes. 									
	<p>[Ex.:]</p>									

GS w n

[Name]	Set bar code width.		
[Format]	ASCII	GS	w n
	Hex.	1D	77 n
	Decimal	29	119 n
[Range]	1 ≤ n ≤ 6 Initial Value n = 2		
[Description]	Sets the bar code horizontal size.		
		Binary Level Bar Code	
	n	Multi-level Bar Code Module Width [mm]	Fine Element Width[mm]
			Thick Element Width[mm]
	1	0.141	0.141
	2	0.282	0.282
	3	0.423	0.423
	4	0.564	0.564
	5	0.706	0.706
	6	0.847	0.847
			2.258

TWO-DIMENSIONAL BAR CODE COMMAND DETAILS

DC2 ; n

[Name]	QR Code Module Size Set		
[Format]	ASCII	DC	; n
	Hex.	12	3B n
	Decimal	18	59 n
[Range]	2 ≤ n ≤ 16 Initial Value n = 2		
[Description]	Specifies a module size of QR Code and Data Matrix. n: The number of dots for one side of the module size.		

GS p 1

[Name]	QR Code Print																		
[Format]	ASCII GS p 1 model e v mode nl nh [data] Hex. 1D 70 01 model e v mode nl nh [data] Decimal 29 112 01 model e v mode nl nh [data]																		
[Range]	model=01, 02 e=4Ch, 4Dh, 51h, 48h $0, 1 \leq v \leq 40$ mode=4Eh, 41h, 42h, 4Bh, 4Dh $1 \leq nh \times 256 + nl \leq 7089$																		
[Description]	<p>Prints QR Code data based on the specified contents. model: Specifies a model e: Selects an error correction level. 'L' (4CH), 'M' (4DH), 'Q' (51H), 'H' (48H) v: =0: Automatic selection (A version is automatically selected depending on the number of input data.) $1 \leq v \leq 40$ Fixed version (up to 14 for model-1) mode: Specifies a mode of data.</p> <table border="1"> <thead> <tr> <th>Mode</th> <th>Hexadecimal</th> <th>Mode</th> </tr> </thead> <tbody> <tr> <td>N</td> <td>4E</td> <td>Numerical mode</td> </tr> <tr> <td>A</td> <td>41</td> <td>Alphanumeric mode</td> </tr> <tr> <td>B</td> <td>42</td> <td>8-bit byte mode</td> </tr> <tr> <td>K</td> <td>4B</td> <td>Kanji mode</td> </tr> <tr> <td>M</td> <td>4D</td> <td>Mixed mode</td> </tr> </tbody> </table> <p>nl, nh: Specifies the number of data. Data: Kanji data of the QR Code data should be set by Shift JIS code.</p>	Mode	Hexadecimal	Mode	N	4E	Numerical mode	A	41	Alphanumeric mode	B	42	8-bit byte mode	K	4B	Kanji mode	M	4D	Mixed mode
Mode	Hexadecimal	Mode																	
N	4E	Numerical mode																	
A	41	Alphanumeric mode																	
B	42	8-bit byte mode																	
K	4B	Kanji mode																	
M	4D	Mixed mode																	

KANJI CONTROL COMMAND DETAILS

FS ! n

[Name]	Set print mode(s) for Kanji characters.			
[Format]	ASCII	FS	!	n
	Hex.	1C	21	n
	Decimal	28	33	n
[Range]	0 ≤ n ≤ 255 Initial Value n = 0			
[Description]	Batch specifies the Kanji character print mode.			
	Bit	Function	"0"	"1"
	7	Underline	Off	On
	6	Undefined		
	5	Undefined		
	4	Undefined		
	3	Double tall expanded	Off	On
	2	Expanded wide	Off	On
	1	Undefined		
	0	Undefined		

FS &

[Name]	Select Kanji character mode.			
[Format]	ASCII	FS	&	
	Hex.	1C	26	
	Decimal	28	38	
[Range]	N/A			
[Description]	Specifies Kanji character mode.			

FS - n

[Name]	Turn underline mode on/off for Kanji characters								
[Format]	ASCII FS - n Hex. 1C 2D n Decimal 28 45 n								
[Range]	$0 \leq n \leq 2, 48 \leq n \leq 50$								
[Description]	<p>Specifies or cancels Kanji character underlines.</p> <table border="1"> <thead> <tr> <th>n</th> <th>Function</th> </tr> </thead> <tbody> <tr> <td>0,48</td> <td>Cancels Kanji character underline</td> </tr> <tr> <td>1,49</td> <td>Sets to one-dot width Kanji character underline and specifies Kanji character underlines.</td> </tr> <tr> <td>2,50</td> <td>Sets to two-dot width Kanji character underline and cancels Kanji character underlines.</td> </tr> </tbody> </table>	n	Function	0,48	Cancels Kanji character underline	1,49	Sets to one-dot width Kanji character underline and specifies Kanji character underlines.	2,50	Sets to two-dot width Kanji character underline and cancels Kanji character underlines.
n	Function								
0,48	Cancels Kanji character underline								
1,49	Sets to one-dot width Kanji character underline and specifies Kanji character underlines.								
2,50	Sets to two-dot width Kanji character underline and cancels Kanji character underlines.								

FS .

[Name]	Cancel Kanji character mode.
[Format]	ASCII FS . Hex. 1C 2E Decimal 28 46
[Range]	N/A
[Description]	Cancels Kanji character mode.

FS S n1 n2

[Name]	Set Kanji character spacing
[Format]	ASCII FS S n1 n2 Hex. 1C 53 n1 n2 Decimal 28 83 n1 n2
[Range]	0 ≤ n1 ≤ 255, 0 ≤ n2 ≤ 255 Initial Value n1 = 0, n2=0
[Description]	Sets the Kanji character space amount and right space amount. <ul style="list-style-type: none"> ● Left space amount: n1 x (basic calculated pitch) ● Right space amount: n2 x (basic calculated pitch)

FS W n

[Name]	Turn quadruple-size mode on/off for Kanji characters.
[Format]	ASCII FS W n Hex. 1C 57 n Decimal 28 87 n
[Range]	0 ≤ n ≤ 255 Initial Value n = 0
[Description]	Specifies or cancels quadruple size Kanji character. <ul style="list-style-type: none"> ● Cancels quadruple size when n = <*****0>B. ● Specifies quadruple size when n = <*****1>B. ● n is effective only when it is the lowest bit.

4.9.1.2 OPOS Printer Driver

The **MB1030_OposSetup.exe** program sets up the registry information of MSRHK reader for OPOS program uses.

1. Installation

The steps below guide you to install the **MB1030_OposSetup** program.

- Run the setup file **MB1030_OposSetup.exe** located in the Software folder of the DVD.
- This setup also installs the **MB1030** program.
- Follow the wizard instructions to complete the installation.

2. Launching the Program

Follow the steps below to load the **MB1030** program:

- Click the *POSPrinter* folder from the path: *Start\Programs\Protech OPOS*.
- Click **MB1030** to launch the program.

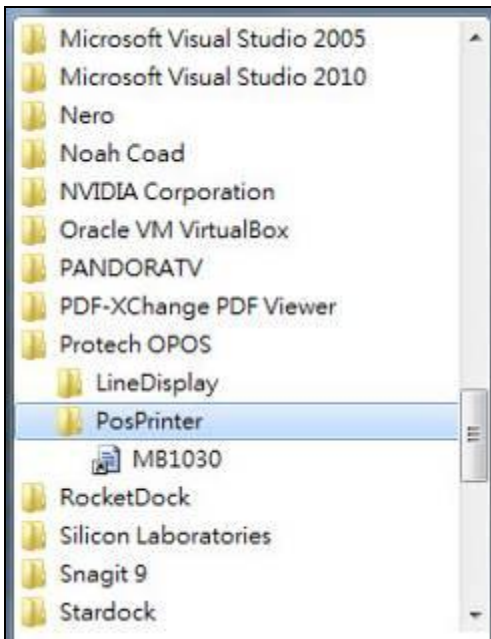

3. OPOS Control Object of MB1030 Program

a.) Print tab buttons:

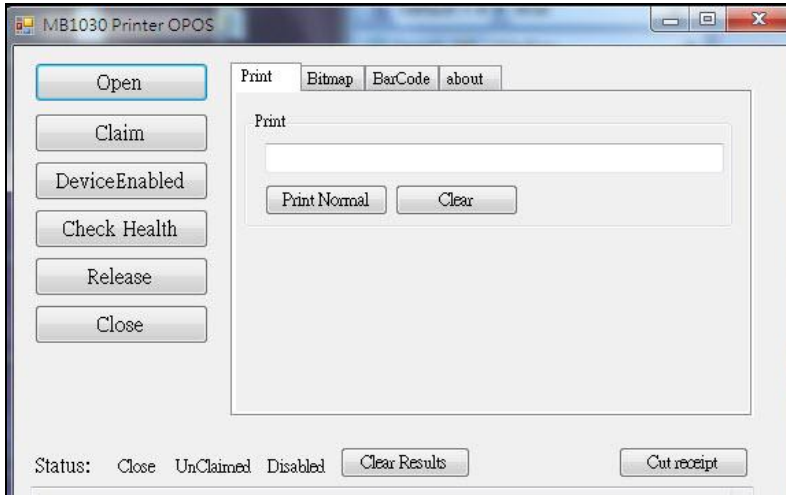

Button/Item	Description
Printer Normal	Print the string.

b.) Bitmap tab buttons/items:

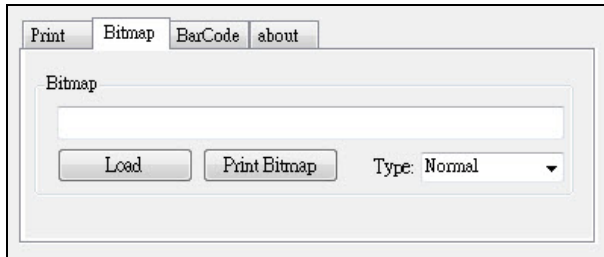

Button/Item	Description
Load	Load bitmap file.
Print Bitmap	Print bitmap file.
Type	Normal or Rotate 108°.

c.) BarCode tab buttons/items:

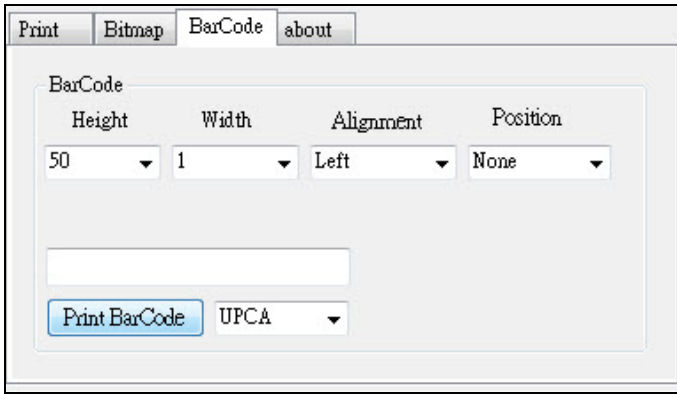

Button/Item	Description
Print BarCode	Print the barcode. Supported barcode types: UPCA, UPCE, EAN8, EAN13, ITF, Codabar, Code39, Code93, Code128
Alignment	Left, center or right
Position	Print barcode number (None, Above or Below)

4. MB1030 type

Key Name	Type	Default Value	Note
BaudRate	String	115200	UART Baud Rate (default)
BitLength	String	8	UART Data Bit (default)
Parity	String	0	UART Parity Bit (default)
Port	String	COM4	UART Port (default)
Stop	String	1	UART Stop Bit (default)

5. OPOS APIs Support List

	Category Type	Name	Mutability	OPOS APG Version	Printer .SO
Properties	common bool	AutoDisable	R/W	1.2	Not Applicable
Properties	common long	BinaryConversion	R/W	1.2	Not Applicable
Properties	common long	CapPowerReporting	Read only	1.3	Not Applicable
Properties	common string	CheckHealthText	Read only	1.0	Supported
Properties	common bool	Claimed	Read only	1.0	Supported
Properties	common long	DataCount	Read only	1.2	Not Applicable
Properties	common bool	DataEventEnabled	Read only	1.0	Not Applicable
Properties	common bool	DeviceEnabled	R/W	1.0	Not Applicable
Properties	common bool	FreezeEvents	R/W	1.0	Supported
Properties	common long	OpenResult	Read only	1.5	Supported
Properties	common bool	OutputID	Read only	1.0	Not Applicable
Properties	common bool	PowerNotify	R/W	1.3	Not Applicable
Properties	common bool	PowerState	Read only	1.3	Not Applicable
Properties	common long	ResultCode	Read only	1.0	Supported
Properties	common long	ResultCodeExtended	Read only	1.0	Not Applicable
Properties	common long	State	Read only	1.0	Supported
Properties	common string	ControlObject Description	Read only	1.0	Not Applicable
Properties	common long	ControlObject Version	Read only	1.0	Not Applicable
Properties	common string	ServiceObject Description	Read only	1.0	Supported
Properties	common long	ServiceObject Version	Read only	1.0	Supported
Properties	common string	DeviceDescription	Read only	1.0	Supported
Properties	common string	ControlObject Description	Read only	1.0	Not Applicable
Properties	specific long	CapCharacterSet	Read only	1.1	Not Applicable
Properties	specific bool	CapConcurrentJrnRec	Read only	1.0	Not Applicable
Properties	specific bool	CapConcurrentJrnSlp	Read only	1.0	Not Applicable
Properties	specific bool	CapCoverSensor	Read only	1.0	Not Applicable
Properties	specific bool	CapTransaction	Read only	1.1	Not Applicable
Properties	specific bool	CapJrnPresent	Read only	1.0	Not Applicable
Properties	specific bool	CapJrn2Color	Read only	1.0	Not Applicable
Properties	specific bool	CapJrnBold	Read only	1.0	Not Applicable
Properties	specific long	CapJrnCartridgeSensor	Read only	1.5	Not Applicable
Properties	specific long	CapJrnColor	Read only	1.5	Not Applicable
Properties	specific long	CapJrnDhigh	Read only	1.0	Not Applicable
Properties	specific long	CapJrnDwide	Read only	1.0	Not Applicable
Properties	specific long	CapJrnDwideDhigh	Read only	1.0	Not Applicable
Properties	specific long	CapJrnEmptySensor	Read only	1.0	Not Applicable

	Category Type	Name	Mutability	OPOS APG Version	Printer .SO
Properties	specific long	CapJrnItalic	Read only	1.0	Not Applicable
Properties	specific long	CapJrnNearEndSensor	Read only	1.0	Not Applicable
Properties	specific bool	CapJrnUnderline	Read only	1.0	Not Applicable
Properties	specific bool	CapRecPresent	Read only	1.0	Not Applicable
Properties	specific bool	CapRec2Color	Read only	1.0	Not Applicable
Properties	specific bool	CapRecBarCode	Read only	1.0	Not Applicable
Properties	specific bool	CapRecBitmap	Read only	1.0	Not Applicable
Properties	specific bool	CapRecBold	Read only	1.0	Not Applicable
Properties	specific long	CapRecCartridgeSensor	Read only	1.5	Not Applicable
Properties	specific long	CapRecColor	Read only	1.5	Not Applicable
Properties	specific bool	CapRecDhigh	Read only	1.0	Not Applicable
Properties	Specific bool	CapRecDwide	Read only	1.0	Not Applicable
Properties	specific bool	CapRecDwideDhigh	Read only	1.0	Not Applicable
Properties	specific bool	CapRecEmptySensor	Read only	1.0	Not Applicable
Properties	specific bool	CapRecItalic	Read only	1.0	Not Applicable
Properties	specific bool	CapRecLeft90	Read only	1.0	Not Applicable
Properties	specific bool	CapRecMarkFeed	Read only	1.5	Not Applicable
Properties	specific bool	CapRecNearEndSensor	Read only	1.0	Not Applicable
Properties	specific bool	CapRecPapercut	Read only	1.0	Not Applicable
Properties	specific bool	CapRecRight90	Read only	1.0	Not Applicable
Properties	specific bool	CapRecRotate180	Read only	1.0	Not Applicable
Properties	specific bool	CapRecStamp	Read only	1.0	Not Applicable
Properties	specific bool	CapRecUnderline	Read only	1.0	Not Applicable
Properties	specific bool	CapSlpPresent	Read only	1.0	Not Applicable
Properties	specific bool	CapSlpFullslip	Read only	1.0	Not Applicable
Properties	specific bool	CapSlp2Color	Read only	1.0	Not Applicable
Properties	specific bool	CapSlpBarCode	Read only	1.0	Not Applicable
Properties	specific bool	CapSlpBitmap	Read only	1.0	Not Applicable
Properties	specific bool	CapSlpBold	Read only	1.0	Not Applicable
Properties	specific bool	CapSlpBothSidesPrint	Read only	1.5	Not Applicable
Properties	specific long	CapSlpCartridgeSensor	Read only	1.5	Not Applicable
Properties	specific long	CapSlpColor	Read only	1.5	Not Applicable
Properties	specific bool	CapSlpDhigh	Read only	1.0	Not Applicable
Properties	specific bool	CapSlpDwide	Read only	1.0	Not Applicable
Properties	specific bool	CapSlpDwideDhigh	Read only	1.0	Not Applicable
Properties	specific bool	CapSlpEmptySensor	Read only	1.0	Not Applicable
Properties	specific bool	CapSlpItalic	Read only	1.0	Not Applicable
Properties	specific bool	CapSlpLeft90	Read only	1.0	Not Applicable
Properties	specific bool	CapSlpNearEndSensor	Read only	1.0	Not Applicable
Properties	specific bool	CapSlpRight90	Read only	1.0	Not Applicable
Properties	specific bool	CapSlpRotate180	Read only	1.0	Not Applicable
Properties	specific bool	CapSlpUnderline	Read only	1.0	Not Applicable
Properties	specific bool	AsyncMode	R/W	1.0	Not Applicable

	Category Type	Name	Mutability	OPOS APG Version	Printer .SO
Properties	specific long	CartridgeNotify	R/W	1.5	Not Applicable
Properties	specific long	CharacterSet	R/W	1.0	Not Applicable
Properties	specific string	CharacterSetList	Read only	1.0	Not Applicable
Properties	specific bool	CoverOpen	Read only	1.0	Not Applicable
Properties	specific long	ErrorLevel	Read only	1.1	Not Applicable
Properties	specific long	ErrorStation	Read only	1.0	Not Applicable
Properties	specific string	ErrorString	Read only	1.1	Not Applicable
Properties	specific string	FontTypefaceList	Read only	1.1	Not Applicable
Properties	specific bool	FlagWhenIdle	R/W	1.0	Not Applicable
Properties	specific long	MapMode	R/W	1.0	Not Applicable
Properties	specific long	RotateSpecial	R/W	1.1	Not Applicable
Properties	specific long	JrnLineChars	R/W	1.0	Not Applicable
Properties	specific string	JrnLineCharsList	Read only	1.0	Not Applicable
Properties	specific long	JrnLineHeight	R/W	1.0	Not Applicable
Properties	specific long	JrnLineSpacing	R/W	1.0	Not Applicable
Properties	specific long	JrnLineWidth	Read only	1.0	Not Applicable
Properties	specific bool	JrnLetterQuality	R/W	1.0	Not Applicable
Properties	specific bool	JrnEmpty	Read only	1.0	Not Applicable
Properties	specific bool	JrnNearEnd	Read only	1.0	Not Applicable
Properties	specific long	JrnCartridgeState	Read only	1.5	Not Applicable
Properties	specific long	JrnCurrentCartridge	R/W	1.5	Not Applicable
Properties	specific long	RecLineChars	R/W	1.0	Not Applicable
Properties	specific string	RecLineCharsList	Read only	1.0	Not Applicable

	Category Type	Name	Mutability	OPOS APG Version	Printer .SO
Properties	specific long	RecLineHeight	R/W	1.0	Not Applicable
Properties	specific long	RecLineSpacing	R/W	1.0	Not Applicable
Properties	specific long	RecLineWidth	Read only	1.0	Not Applicable
Properties	specific bool	RecLetterQuality	R/W	1.0	Not Applicable
Properties	specific bool	RecEmpty	Read only	1.0	Not Applicable
Properties	specific bool	RecNearEnd	Read only	1.0	Not Applicable
Properties	specific long	RecSidewaysMaxLines	Read only	1.0	Not Applicable
Properties	specific long	RecSidewaysMaxChars	Read only	1.0	Not Applicable
Properties	specific long	RecLinesToPaperCut	Read only	1.0	Not Applicable
Properties	specific string	RecBarCodeRotationList	Read only	1.1	Not Applicable
Properties	specific long	RecCartridgeState	Read only	1.5	Not Applicable
Properties	specific long	RecCurrentCartridge	R/W	1.5	Not Applicable
Properties	specific long	SlpLineChars	R/W	1.0	Not Applicable
Properties	specific string	SlpLineCharsList	Read only	1.0	Not Applicable
Properties	specific long	SlpLineHeight	R/W	1.0	Not Applicable
Properties	specific long	SlpLineSpacing	R/W	1.0	Not Applicable
Properties	specific long	SlpLineWidth	Read only	1.0	Not Applicable
Properties	specific bool	SlpLetterQuality	R/W	1.0	Not Applicable
Properties	specific bool	SlpEmpty	Read only	1.0	Not Applicable
Properties	specific bool	SlpNearEnd	Read only	1.0	Not Applicable
Properties	specific long	SlpSidewaysMaxLines	Read only	1.0	Not Applicable
Properties	specific long	SlpSidewaysMaxChars	Read only	1.0	Not Applicable
Properties	specific long	SlpMaxLines	Read only	1.0	Not Applicable
Properties	specific long	SlpLinesNearEndToEnd	Read only	1.0	Not Applicable
Properties	specific string	SlpBarCodeRotationList	Read only	1.1	Not Applicable
Properties	specific long	SlpPrintSide	Read only	1.5	Not Applicable
Properties	specific long	SlpCartridgeState	Read only	1.5	Not Applicable
Properties	specific long	SlpCurrentCartridge	R/W	1.5	Not Applicable
Methods	common	Open	-	1.0	Supported
Methods	common	Close	-	1.0	Supported
Methods	common	Claim	-	1.0	Supported
Methods	common	ClaimDevice	-	1.0	Supported
Methods	common	Release	-	1.0	Supported
Methods	common	ReleaseDevice	-	1.0	Supported
Methods	common	CheckHealth	-	1.0	Supported
Methods	common	ClearInput	-	1.0	Not Applicable
Methods	common	ClearOutput	-	1.0	Not Applicable
Methods	common	DirectIO	-	1.0	Not Applicable

Chapter 4 Software Utilities

	Category Type	Name	Mutability	OPOS APG Version	Printer .SO
Methods	specific	PrintNormal	-	1.0	Supported
Methods	specific	PrintTwoNormal	-	1.0	Not Applicable
Methods	specific	PrintImmediate	-	1.0	Not Applicable
Methods	specific	BeginInsertion	-	1.0	Not Applicable
Methods	specific	EndInsertion	-	1.0	Not Applicable
Methods	specific	BeginRemoval	-	1.0	Not Applicable
Methods	specific	EndRemoval	-	1.0	Not Applicable
Methods	specific	CutPaper	-	1.0	Supported
Methods	specific	RotatePrint	-	1.0	Supported (only 180)
Methods	specific	PrintBarCode	-	1.0	Supported
Methods	specific	PrintBitmap	-	1.0	Supported
Methods	specific	TransactionPrint	-	1.1	Not Applicable
Methods	specific	ValidateData	-	1.1	Not Applicable
Methods	specific	SetBitmap	-	1.0	Not Applicable
Methods	specific	SetLogo	-	1.0	Not Applicable
Methods	specific	ChangePrintSide	-	1.5	Not Applicable
Methods	specific	MarkFeed	-	1.5	Not Applicable
Events	common	DataEvent	-	1.0	Not Applicable
Events	common	DirectIOEvent	-	1.0	Not Applicable
Events	common	ErrorEvent	-	1.0	Not Applicable
Events	common	OutputComplete Event	-	1.0	Not Applicable
Events	common	StatusUpdate Event	-	1.0	Not Applicable

4.9.2 VFD: MB-4103 (RS-232)

4.9.2.1 Commands List

1. VFD Registry Operation

Registry Path:

[HKEY_LOCAL_MACHINE\SOFTWARE\OLEforRetail\ServiceOPOS\LineDisplay\Prox-PMP4000]

Registry Name	Default Data	Notes
Default Value	LineDisplay.PMP4000.1	-
BaudRate	9600	-
BitLength	8	-
Parity	0	-
Port	COM1	-
Stop	1	-

2. OPOS VFD Service Object and Method Relations

Method	Status of Support	Notes
Open	○	-
Close	○	-
ClaimDevice	○	-
ReleaseDevice	○	-
Enable	○	-
Disable	○	-
DisplayText	○	-
DisplayTextAt	○	-
ClearText	○	-

4.9.2.2 OPOS Driver

The **MB4000_OposSetup.exe** program sets up the registry information and example program of VFD for OPOS program uses.

1. Installation

The steps below guide you to install the **MB4000_OposSetup** program:

- Run the **MB4000_OposSetup** setup file
- This setup also installs the **Prox-PMP4000** program.
- Follow the onscreen wizard instructions to complete the installation.

2. Launching the Program

The steps below guide you to load the **Prox-PMP4000** program:

- Click the *LineDisplay* folder from the path: *Start/Programs/Protech OPOS*.
- Click **Prox-PMP4000** to launch the program.

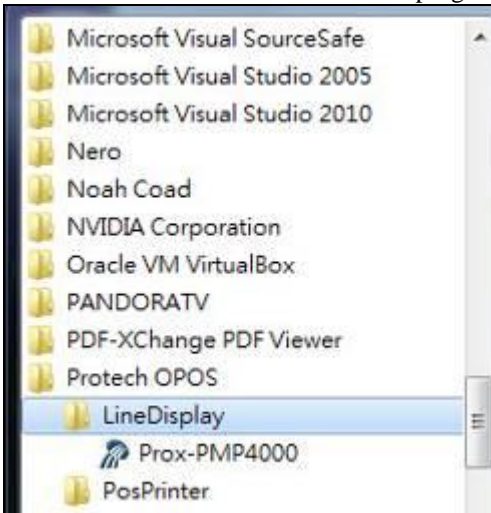

3. OPOS Control Object of Prox-PMP4000 program

Main screen buttons:

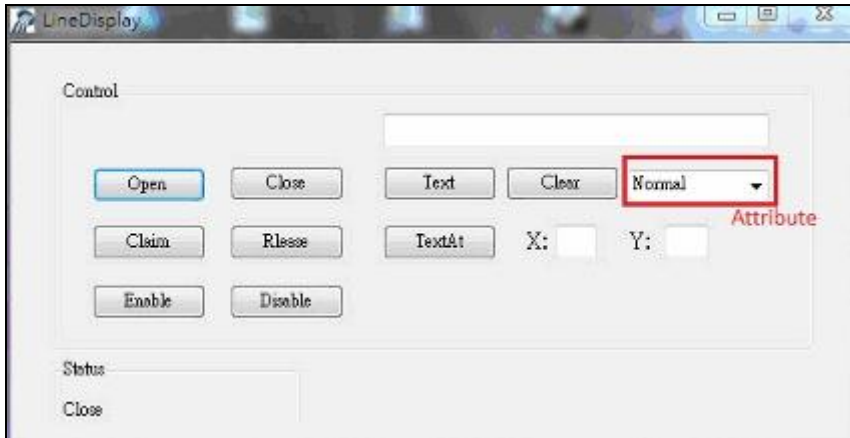

Button/Item	Description
Text	Display the text at the current cursor position.
TextAt	Display the string of characters at the point of the specified “y-coordinate” and “x-coordinate”.
Clear	Clear the message shown in the current window.
Attribute	<ul style="list-style-type: none"> • Normal: Display the normal characters on the display screen. • Blink: Enable the display screen to blink. • Reverse: Enable the character printing in reverse black and white. • Blink+Reverse: Enable the display screen to blink and activate the character printing in reverse black and white.

4. MB4103 type

Key Name	Type	Default Value	Note
BaudRate	String	9600	UART Baud Rate (default)
BitLength	String	8	UART Data Bit (default)
Parity	String	0	UART Parity Bit (default)
Port	String	COM1	UART Port (default)
Stop	String	1	UART Stop Bit (default)

5. OPOS APIs Support List

	Category Type	Name	Mutability	OPOS APG Version	VFD .SO
Properties	common bool	AutoDisable	R/W	1.2	Not Applicable
Properties	common long	BinaryConversion	R/W	1.2	Not Applicable
Properties	common long	CapPowerReporting	Read only	1.3	Not Applicable
Properties	common string	CheckHealthText	Read only	1.0	Supported
Properties	common bool	Claimed	Read only	1.0	Supported
Properties	common long	DataCount	Read only	1.2	Not Applicable
Properties	common bool	DataEventEnabled	Read only	1.0	Not Applicable
Properties	common bool	DeviceEnabled	R/W	1.0	Not Applicable
Properties	common bool	FreezeEvents	R/W	1.0	Not Applicable
Properties	common long	OpenResult	Read only	1.5	Not Applicable
Properties	common bool	OutputID	Read only	1.0	Not Applicable
Properties	common bool	PowerNotify	R/W	1.3	Not Applicable
Properties	common bool	PowerState	Read only	1.3	Not Applicable
Properties	common long	ResultCode	Read only	1.0	Supported
Properties	common long	ResultCodeExtended	Read only	1.0	Not Applicable
Properties	common long	State	Read only	1.0	Supported
Properties	common string	ControlObject Description	Read only	1.0	Not Applicable
Properties	common long	ControlObject Version	Read only	1.0	Not Applicable
Properties	common string	ServiceObject Description	Read only	1.0	Supported
Properties	common long	ServiceObject Version	Read only	1.0	Supported
Properties	common string	DeviceDescription	Read only	1.0	Supported
Properties	common string	ControlObject Description	Read only	1.0	Not Applicable
Properties	specific long	CapBlink	Read only	1.0	Not Applicable
Properties	specific bool	CapBlinkRate	Read only	1.6	Not Applicable
Properties	specific bool	CapBrightness	Read only	1.0	Not Applicable
Properties	specific long	CapCharacterSet	Read only	1.0	Not Applicable
Properties	specific long	CapCursorType	Read only	1.6	Not Applicable
Properties	specific bool	CapCustomGlyph	Read only	1.6	Not Applicable
Properties	specific bool	CapDescriptors	Read only	1.0	Not Applicable
Properties	specific bool	CapHMarquee	Read only	1.0	Not Applicable
Properties	specific bool	CapICharWait	Read only	1.0	Not Applicable
Properties	specific long	CapReadBack	Read only	1.6	Not Applicable
Properties	specific long	CapReverse	Read only	1.6	Not Applicable
Properties	specific bool	CapVMarquee	Read only	1.0	Not Applicable
Properties	specific long	BlinkRate	R/W	1.6	Not Applicable
Properties	specific long	DeviceWindows	Read only	1.0	Not Applicable

	Category Type	Name	Mutability	OPOS APG Version	VFD .SO
Properties	specific long	DeviceRows	Read only	1.0	Not Applicable
Properties	specific long	DeviceColumns	Read only	1.0	Not Applicable
Properties	specific long	DeviceDescriptors	Read only	1.0	Not Applicable
Properties	specific long	DeviceBrightness	R/W	1.0	Not Applicable
Properties	specific long	CharacterSet	R/W	1.0	Not Applicable
Properties	specific string	CharacterSetList	Read only	1.0	Not Applicable
Properties	specific long	CurrentWindow	R/W	1.0	Not Applicable
Properties	specific long	Rows	Read only	1.0	Not Applicable
Properties	specific long	Columns	Read only	1.0	Not Applicable
Properties	specific long	CursorRow	R/W	1.0	Not Applicable
Properties	specific long	CursorColumn	R/W	1.0	Not Applicable
Properties	specific long	CursorType	R/W	1.6	Not Applicable
Properties	specific bool	CursorUpdate	R/W	1.0	Not Applicable
Properties	specific long	MarqueeType	R/W	1.0	Not Applicable
Properties	specific long	MarqueeFormat	R/W	1.0	Not Applicable
Properties	specific long	MarqueeUnitWait	R/W	1.0	Not Applicable
Properties	specific long	MarqueeRepeatWait	R/W	1.0	Not Applicable
Properties	specific long	InterCharacterWait	R/W	1.0	Not Applicable
Properties	specific string	CustomGlyphList	Read only	1.6	Not Applicable
Properties	specific long	GlyphHeight	Read only	1.6	Not Applicable
Properties	specific long	GlyphWidth	Read only	1.6	Not Applicable
Methods	common	Open	-	1.0	Supported
Methods	common	Close	-	1.0	Supported
Methods	common	Claim	-	1.0	Supported
Methods	common	ClaimDevice	-	1.0	Supported
Methods	common	Release	-	1.0	Supported
Methods	common	ReleaseDevice	-	1.0	Supported
Methods	common	CheckHealth	-	1.0	Not Applicable
Methods	common	ClearInput	-	1.0	Not Applicable
Methods	common	ClearOutput	-	1.0	Not Applicable
Methods	common	DirectIO	-	1.0	Not Applicable
Methods	specific	DisplayText	-	1.0	Supported
Methods	specific	DisplayTextAt	-	1.0	Supported
Methods	specific	ClearText	-	1.0	Supported
Methods	specific	ScrollText	-	1.0	Not Applicable
Methods	specific	SetDescriptor	-	1.0	Not Applicable
Methods	specific	ClearDescriptors	-	1.0	Not Applicable

	Category Type	Name	Mutability	OPOS APG Version	VFD .SO
Methods	specific	CreateWindow	-	1.0	Not Applicable
Methods	specific	DestroyWindow	-	1.0	Not Applicable
Methods	specific	RefreshWindow	-	1.0	Not Applicable)
Methods	specific	ReadCharacterAtCursor	-	1.6	Not Applicable
Methods	specific	DefineGlyph	-	1.6	Not Applicable
Events	common	DataEvent	-	1.0	Not Applicable
Events	common	DirectIOEvent	-	1.0	Not Applicable
Events	common	ErrorEvent	-	1.0	Not Applicable
Events	common	OutputComplete Event	-	1.0	Not Applicable
Events	common	StatusUpdate Event	-	1.3	Not Applicable

4.9.3 MSR: MB-3102 (PS/2)

4.9.3.1 OPOS Driver

The **MB301X_OposSetup.exe** program sets up the registry information of the MSR reader for OPOS programming use.

1. Installation

The steps below guide you to install the **MB301X_OposSetup** program.

- Run the **OPOSMSR_Setup.exe** setup file.
- This setup also installs the Prox-PMP3000 program.
- Follow the onscreen wizard instructions to complete the installation.

2. Launching the Program

The steps below guide you to load the **Prox-PMP3000** program.

- Click the *MSR* folder from the path: *Start/Programs/Protech OPOS*.
- Click **Prox-PMP3000** to launch the program.

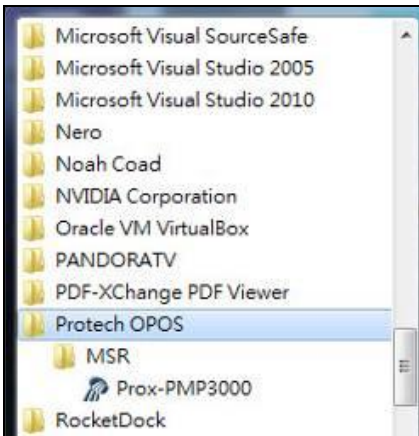

2. Configuration of **Prox-PMP3000** program
 - a.) Main screen & Control tab items:

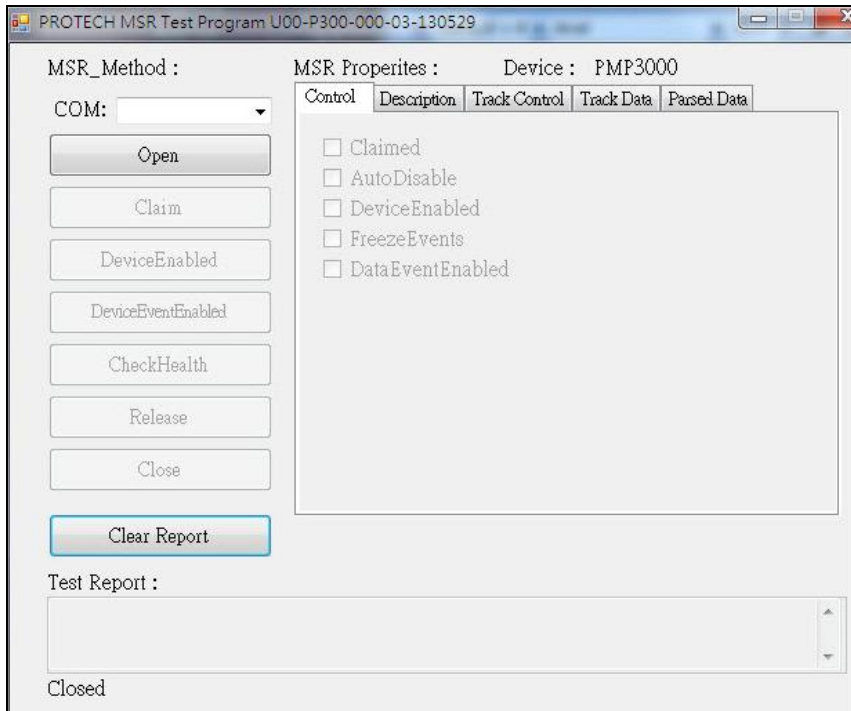

Button/Item	Description
COM	Select the COM port number from the drop-down list. (only for UART/USB interface).
AutoDisable	(check box) Check to disable the device automatically when data is received.
FreezeEvents	(check box) Enable to trigger FreezeEvents , and the application will not allow events to be delivered.

b.) Description tab: S.O and C.O information

Control	Description	Track Control	Track Data	Parsed Data
DeviceControlDescription :				
OPOS MSR Control 1.6.000 [Public, by CRM/RCS-Dayton]				
DeviceControlVersion :				
1006000				
DeviceServiceDescription :				
PROTECH OPOS MSR Service Object				
DeviceServiceVersion :				
1007550				
PhysicalDeviceDescription :				
PROTECH OPOS MSR				
PhysicalDeviceName :				
OPOS.PMP3000MSR.SO				

c.) Track Control tab items

Control	Description	Track Control	Track Data	Parsed Data
<input checked="" type="checkbox"/>	DecodeData	ErrorReportingType :		
<input checked="" type="checkbox"/>	ParseDecodeData	CARD		
<input type="checkbox"/>	TransmitSentinels	TracksToRead :		
		Tracks123		

Button/Item	Description
DecodeData	Set decode data properties applicable.
ParseDecodeData	Set parse decode data properties
TransmitSentinels	Set transmit-sentinels properties
ErrorReporting Type	Card, track
TracksToRead	Track1, track2, track3, tracks12, tracks13, tracks14, tracks23, tracks24, tracks34, tracks123, tracks124, tracks134, tracks234, tracks1234 (Tracks4 is not applicable).

d.) Track Data tab items

Control	Description	Track Control	Track Data	Parsed Data
Track1Data :	<input type="text"/>			
Track1DiscretionaryData :	<input type="text"/>			
Track2Data :	<input type="text"/>			
Track2DiscretionaryData :	<input type="text"/>			
Track3Data :	<input type="text"/>			
Track4Data :	<input type="text"/>			

Button/Item	Description
TracksData	(Row) Display the data of all tracks (Track4 is not applicable).

e.) Parsed Data tab items

Control	Description	Track Control	Track Data	Parsed Data
AccountNumber :	<input type="text"/>			
ExpirationDate :	<input type="text"/>			
FirstName :	<input type="text"/>			
MiddleInitial :	<input type="text"/>			
Surname :	<input type="text"/>			
Title :	<input type="text"/>			
Suffix :	<input type="text"/>			
ServiceCode :	<input type="text"/>			

Button/Item	Description
Parsed Data	Display special properties.

3. MB301X type (RS232/PS2)

Key Name	Type	Default Value	Note
default	string	PMP3000	OPOS S.O Link

4. OPOS APIs support List

	Category Type	Name	Mutability	OPOS APG Version	VFD .SO
Properties	common bool	AutoDisable	R/W	1.2	Supported
Properties	common long	BinaryConversion	R/W	1.2	Not Applicable
Properties	common long	CapPowerReporting	Read only	1.3	Supported
Properties	common string	CheckHealthText	Read only	1.0	Supported
Properties	common bool	Claimed	Read only	1.0	Supported
Properties	common long	DataCount	Read only	1.2	Supported
Properties	common bool	DataEventEnabled	R/W	1.0	Supported
Properties	common bool	DeviceEnabled	R/W	1.0	Supported
Properties	common bool	FreezeEvents	R/W	1.0	Supported
Properties	common long	OpenResult	Read only	1.5	Supported
Properties	common long	OutputID	Read only	1.0	Not Applicable
Properties	common long	PowerNotify	R/W	1.3	Not Applicable
Properties	common long	PowerState	Read only	1.3	Not Applicable
Properties	common long	ResultCode	Read only	1.0	Supported
Properties	common long	ResultCodeExtended	Read only	1.0	Supported
Properties	common long	State	Read only	1.0	Not Applicable
Properties	common string	ControlObject Description	Read only	1.0	Not Applicable
Properties	common long	ControlObjectVersion	Read only	1.0	Not Applicable
Properties	common string	ServiceObject Description	Read only	1.0	Supported
Properties	common long	ServiceObjectVersion	Read only	1.0	Not Applicable
Properties	common string	DeviceDescription	Read only	1.0	Supported
Properties	common string	DeviceName	Read only	1.0	Supported
Properties	specific bool	CapISO	Read only	1.0	Supported
Properties	specific bool	CapJISOne	Read only	1.0	Supported
Properties	specific bool	CapJISTwo	Read only	1.0	Supported
Properties	specific bool	CapTransmitSentinels	Read only	1.5	Supported
Properties	specific long	TracksToRead	R/W	1.0	Supported
Properties	specific bool	DecodeData	R/W	1.0	Not Applicable
Properties	specific bool	ParseDecodeData	R/W	1.0	Supported
Properties	specific long	ErrorReportType	R/W	1.2	Not Applicable
Properties	specific string	Track1Data	Read only	1.0	Supported

	Category Type	Name	Mutability	OPOS APG Version	VFD .SO
Properties	specific string	Track2Data	Read only	1.0	Supported
Properties	specific string	Track3Data	Read only	1.0	Supported
Properties	specific string	Track4Data	Read only	1.5	Not Applicable
Properties	specific string	AccountNumber	Read only	1.0	Supported
Properties	specific string	ExpirationDate	Read only	1.0	Supported
Properties	specific string	Title	Read only	1.0	Supported
Properties	specific string	FirstName	Read only	1.0	Supported
Properties	specific string	MiddleInitial	Read only	1.0	Supported
Properties	specific string	Surname	Read only	1.0	Supported
Properties	specific string	Suffix	Read only	1.0	Supported
Properties	specific string	ServiceCode	Read only	1.0	Supported
Properties	specific binary	Track1 DiscretionaryData	Read only	1.0	Supported
Properties	specific binary	Track2 DiscretionaryData	Read only	1.0	Supported
Properties	specific bool	TransmitSentinels	R/W	1.5	Supported
Methods	common	Open	-	1.0	Supported
Methods	common	Close	-	1.0	Supported
Methods	common	Claim	-	1.0	Supported
Methods	common	ClaimDevice	-	1.5	Supported
Methods	common	Release	-	1.0	Supported
Methods	common	ReleaseDevice	-	1.5	Supported
Methods	common	CheckHealth	-	1.0	Not Applicable
Methods	common	ClearInput	-	1.0	Supported
Methods	common	ClearOutput	-	1.0	Not Applicable
Methods	common	DirectIO	-	1.0	Not Applicable
Events	common	DataEvent	-	1.0	Supported
Events	common	DirectIOEvent	-	1.0	Not Applicable
Events	common	ErrorEvent	-	1.0	Not Applicable
Events	common	OutputCompleteEvent	-	1.0	Not Applicable
Events	common	StatusUpdateEvent	-	1.0	Not Applicable

4.9.4 MSR: GIGA-TMS MJR243 (RS-232)

4.9.4.1 Commands List

1. MSR Registry Operation

Registry Path:

[HKEY_LOCAL_MACHINE\SOFTWARE\OLEforRetail\ServiceOPOS\
MSR\MJR243]

Registry Name	Default Data	Notes
CapISO	1	Capability for reading ISO track data
CapJISOne	1	(reserved)
CapJISTwo	1	(reserved)
CapTransmitSentinels	1	Capability for reading Transmit Sentinels
Debug	0	Enable the tracing and create a log file
Description	GIGATMS MSR POS	Description for SO driver
DeviceName	MJR243	Device Name for CO open
FileName	(NULL)	(reserved)
HardwareProvider	0	(reserved)
Model	MJR243	Device model name
Parity	None	Parity for the communication port
Port	COM4	COM Port
Protocol	Hardware	Communication Control
Baudrate	19200	RS-232 baudrate

2. OPOS MSR Service Object and Method Relations

Method	Status of support by the driver	Notes
Open	○	-
Close	○	-
Claim	○	-
ClaimDevice	○	-
Release	○	-
ReleaseDevice	○	-
ClearInput	○	-
ClearInputProperties	○	-
DataEvent	○	-
Claimed	○	Read only
DataCount	○	Read only
DataEventEnabled	○	R/W
DeviceEnabled	○	R/W
FreezeEvents	○	R/W
OpenResult	○	Read only
ResultCode	○	Read only
ResultCodeExtended	○	Read only
State	○	Read only
ControlObjectDescription	○	Read only
ControlObjectVersion	○	Read only
ServiceObjectDescription	○	Read only
ServiceObjectVersion	○	Read only
DeviceDescription	○	Read only
DeviceName	○	Read only
CapISO	○	Read only
CapTransmitSentinels	○	Read only
AccountNumber	○	Read only
DecodeData	○	R/W
ExpirationDate	○	Read only
FirstName	○	Read only
MiddleInitial	○	Read Only
ParseDecodeData	○	R/W
ServiceCode	○	Read Only
Suffix	○	Read Only
Surname	○	Read Only
Title	○	Read Only
Track1Data	○	Read Only
Track1DiscretionaryData	○	Read Only

Method	Status of support by the driver	Notes
Track2Data	○	Read Only
Track2DiscretionaryData	○	Read Only
Track3Data	○	Read Only
TracksToRead	○	R/W
TransmitSentinels	○	R/W

4.9.4.2 OPOS MSR Register

The **OPOS MSR Register** program sets up the registry information of MSRHK reader for OPOS program usage.

1. Installation

The steps below guides you how to install the **OPOS MSR Register** program.

- Insert the setup DVD
- Run the setup file **OPOSMSR_Setup.exe** located in the Software folder of the DVD.
- This setup also installs the **OPOS MSR Tester** program.
- Follow the onscreen wizard instructions to complete the installation.

2. Launching the Program

The steps below guides you how to load the **OPOS MSR Register** program.

- Click the *OPOS* folder from the path: *Start/Programs/GIGA-TMS*.
- Click **OPOS MSR Register** to launch the program.

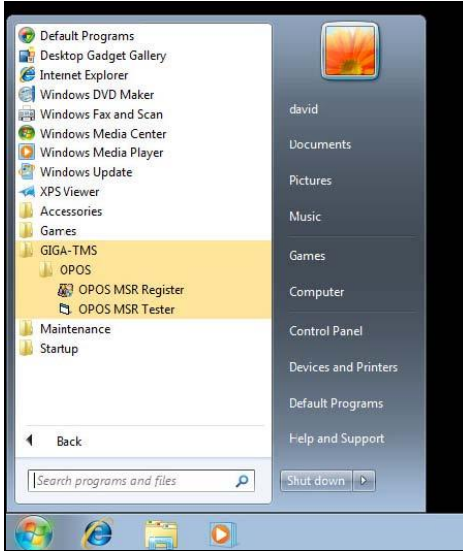

3. Configuration of **OPOS MSR Register** program

a.) Main screen buttons/items:



Button/Item	Description
Control Object	(Check box) Register the OPOSMSR.ocx common control object driver. The item needs to be checked to run the OPOS MSR Tester program.
Service Object	(Left pane) The Service Object driver types. So far only four driver types are supported. Each driver type supports specific MSR readers. Please refer to the OPOS MSR Service Object and Method Relations section for details.
Service Object	(Right pane) The registered MSR with the specified device name.
Reg→	Create a new device name for the selected MSR.
← Unreg	Remove the selected device name from the registry.
Exit	Quit the program.

b.) Follow the steps below to register the MSRHK OPOS information:

Step 1: Select an item in the **Service Object** List box from the left pane. Make sure the correct item is selected.

Step 2: Click **Reg→** button

Step 3: In the **OPOS MSR Setting** screen, enter the device name and click **OK**.

c.) Example 1. MAGTEK USB HID

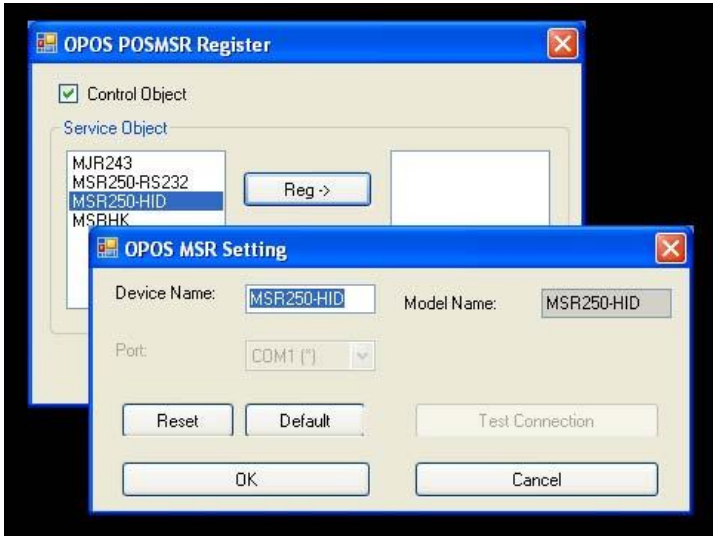

d.) Example 2. PROMAG MSR/MJR PART- NO, Keyboard mode.



e.) Example 3. PROGRAM MSR PART- NO, HID mode.

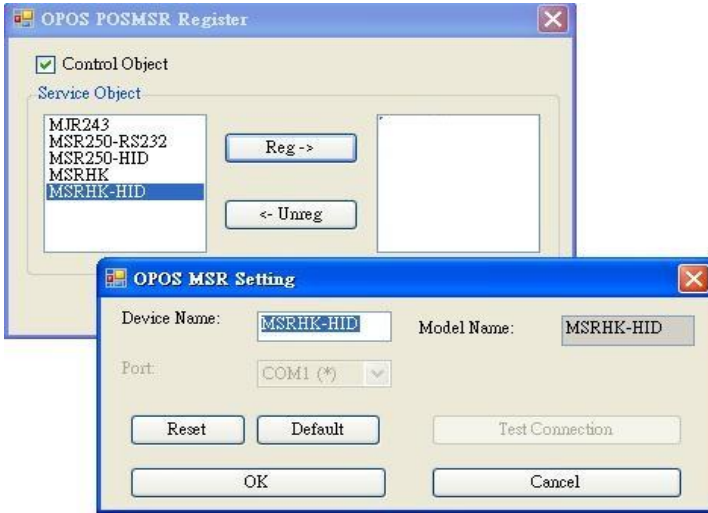

If your system doesn't have any other common control driver, click the **Control Object** check box.

Note: To run the **OPOPS MSR Tester** program, the Control Object must be checked.

4. MJR243 type

Key Name	Type	Default Value	Note
CapISO	string	1	Capability for reading ISO track data
CapJISOne	string	1	(reserved)
CapJISTwo	string	1	(reserved)
CapTransmitSentinels	string	1	Capability for reading Transmit Sentinels
Debug	string	0	Enable the tracing and create a log file.
Description	string	GIGATMS MSR POS	Description for SO driver
DeviceName	string	MJR243	Device Name for CO open
FileName	string	(NULL)	(reserved)
HardwareProvider	string	0	(reserved)
Model	string	MJR243	Device model name
Parity	string	None	Parity for the communication port

Key Name	Type	Default Value	Note
Port	string	COM4	COM Port Number
Protocol	string	Hardware	Communication Control
Baudrate	string	19200	RS-232 baudrate

5. OPOS APIs support list

	Category Type	Name	Mutability	OPOS APG Version	MSR .SO
Properties	common bool	AutoDisable	R/W	1.2	Not Applicable
Properties	common long	BinaryConversion	R/W	1.2	Not Applicable
Properties	common bool	CapCompare FirmwareVersion	Read only	1.9	Not Applicable
Properties	common long	CapPowerReporting	Read only	1.3	Not Applicable
Properties	common bool	CapStatisticsReporting	Read only	1.8	Not Applicable
Properties	common bool	CapUpdateFirmware	Read only	1.9	Not Applicable
Properties	common bool	CapUpdateStatistics	Read only	1.8	Not Applicable
Properties	common string	CheckHealthText	Read only	1.0	Not Applicable
Properties	common bool	Claimed	Read only	1.0	Supported
Properties	common long	DataCount	Read only	1.2	Supported
Properties	common bool	DataEventEnabled	R/W	1.0	Supported
Properties	common bool	DeviceEnabled	R/W	1.0	Supported
Properties	common bool	FreezeEvents	R/W	1.0	Supported
Properties	common long	OpenResult	Read only	1.5	Supported
Properties	common long	OutputID	Read only	1.0	Not Applicable
Properties	common long	PowerNotify	R/W	1.3	Not Applicable
Properties	common long	PowerState	Read only	1.3	Not Applicable
Properties	common long	ResultCode	Read only	1.0	Supported
Properties	common long	ResultCodeExtended	Read only	1.0	Supported
Properties	common long	State	Read only	1.0	Supported
Properties	common string	ControlObject Description	Read only	1.0	Supported
Properties	common long	ControlObjectVersion	Read only	1.0	Supported
Properties	common string	ServiceObject Description	Read only	1.0	Supported
Properties	common long	ServiceObjectVersion	Read only	1.0	Supported
Properties	common string	DeviceDescription	Read only	1.0	Supported
Properties	common string	DeviceName	Read only	1.0	Supported
Properties	specific bool	CapISO	Read only	1.0	Supported
Properties	specific bool	CapJISOne	Read only	1.0	Not Applicable
Properties	specific bool	CapJISTwo	Read only	1.0	Not Applicable
Properties	specific bool	CapTransmit	Read only	1.5	Supported

	Category Type	Name	Mutability	OPOS APG Version	MSR .SO
		Sentinels			
Properties	specific long	CapWriteTracks	Read only	1.1	Not Applicable
Properties	specific string	AccountNumber	Read only	1.0	Supported
Properties	specific bool	DecodeData	R/W	1.0	Supported
Properties	specific long	EncodingMaxLength	Read only	1.1	Not Applicable
Properties	specific long	ErrorReportType	R/W	1.2	Not Applicable
Properties	specific string	ExpirationDate	Read only	1.0	Supported
Properties	specific string	FirstName	Read only	1.0	Supported
Properties	specific string	MiddleInitial	Read only	1.0	Supported
Properties	specific bool	ParseDecodeData	R/W	1.0	Supported
Properties	specific string	ServiceCode	Read only	1.0	Supported
Properties	specific string	Suffix	Read only	1.0	Supported
Properties	specific string	Surname	Read only	1.0	Supported
Properties	specific string	Title	Read only	1.0	Supported
Properties	specific binary	Track1Data	Read only	1.0	Supported
Properties	specific binary	Track1 DiscretionaryData	Read only	1.0	Supported
Properties	specific binary	Track2Data	Read only	1.0	Supported
Properties	specific binary	Track2 DiscretionaryData	-	1.0	Supported
Properties	specific binary	Track3Data	Read only	1.0	Supported
Properties	specific binary	Track4Data	Read only	1.5	Not Applicable
Properties	specific long	TracksToRead	R/W	1	Supported
Properties	specific long	TracksToWrite	R/W	1.1	Not Applicable
Properties	specific bool	TransmitSentinels	R/W	1.5	Supported
Methods	common	Open	-	1	Supported
Methods	common	Close	-	1	Supported
Methods	common	Claim	-	1	Supported
Methods	common	ClaimDevice	-	1.5	Supported
Methods	common	Release	-	1	Supported
Methods	common	ReleaseDevice	-	1.5	Supported
Methods	common	CheckHealth	-	1	Not Applicable
Methods	common	ClearInput	-	1	Supported
Methods	common	ClearInput Properties	-	1.1	Supported
Methods	common	ClearOutput	-	1	Not Applicable
Methods	common	DirectIO	-	1	Not Applicable
Methods	common	Compare FirmwareVersion	-	1.9	Not Applicable

	Category Type	Name	Mutability	OPOS APG Version	MSR .SO
Methods	common	ResetStatistics	-	1.8	Not Applicable
Methods	common	RetrieveStatistics	-	1.8	Not Applicable
Methods	common	UpdateFirmware	-	1.9	Not Applicable
Methods	common	UpdateStatistics	-	1.8	Not Applicable
Events	common	DataEvent	-	1.0	Supported
Events	common	DirectIOEvent	-	1.0	Not Applicable
Events	common	ErrorEvent	-	1.0	Not Applicable
Events	common	OutputCompleteEvent	-	1.0	Not Applicable
Events	common	StatusUpdateEvent	-	1.0	Not Applicable

4.9.4.3 OPOS MSR Tester

The **OPOS MSR Tester** program is used to get the track data of the MSRHK reader via the OPOS driver. Before running the program, make sure the device name registry information for MSRHK reader has been created by OPOS MSR Register program.

1. Installation

The installation of **OPOS MSR Tester** program goes together with OPOS MSR Register program.

2. Launching the Program

The steps below guide you to load the **OPOS MSR Tester** program.

- Click the *OPOS* folder from the path: *Start\Programs\GIGA-TMS*.
- Click **OPOS MSR Tester** to launch the program.



3. Configuration for OPOS MSR Tester Program

a.) Main screen buttons/items:

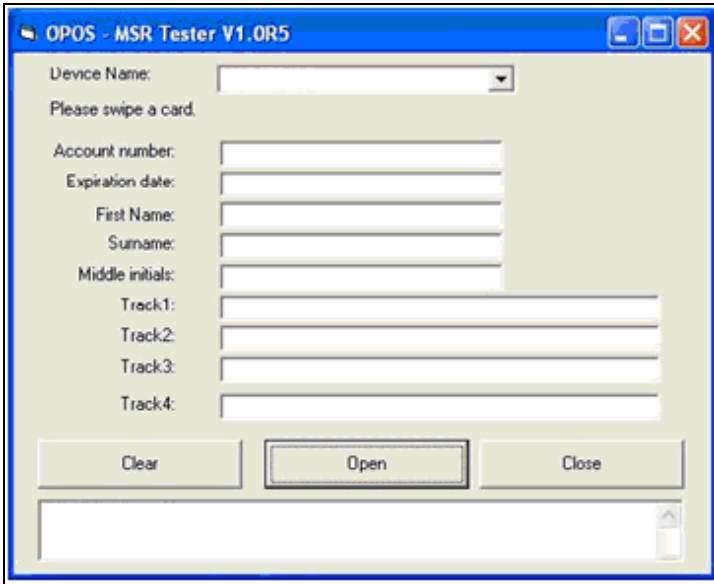

Button/Item	Description
Device Name	(Combo box) Enter the device name that will be loaded to the program.
Track Data	(Text boxes) Show the raw and parsed track data.
Clear	(Button) Clear all the track data in the text boxes.
Open	(Button) Open the OPOS driver and ready to get track data.
Close	(Button) Close the OPOS driver.
Message	(Text box) Display the result message of running the OPOS driver.

b.) To get the track data using OPOS driver, follow the steps below:

Step 1: Enter the **Device Name**.

Step 2: Click **Open** button.

Step 3: Swipe the card to get the track data.

c.) Example 1. MAGTEK USB HID.

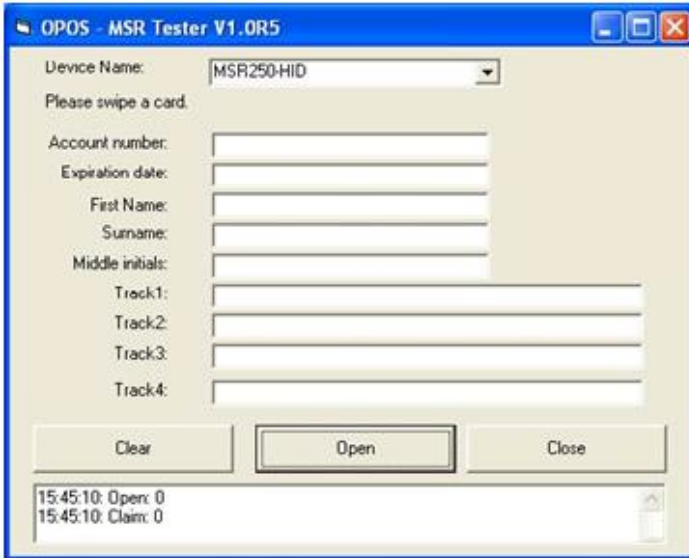

d.) Example 2. PROMAG MSR/MJR PART- NO, Keyboard mode

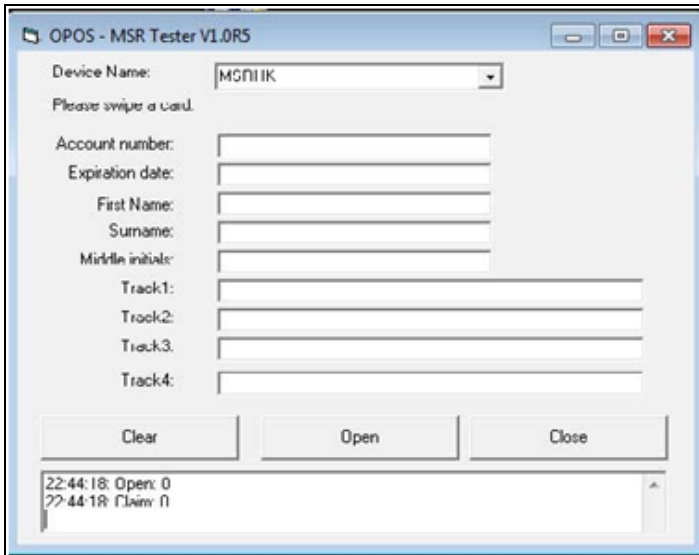

e.) Example 3. PROMAG MSR PART- NO, HID mode

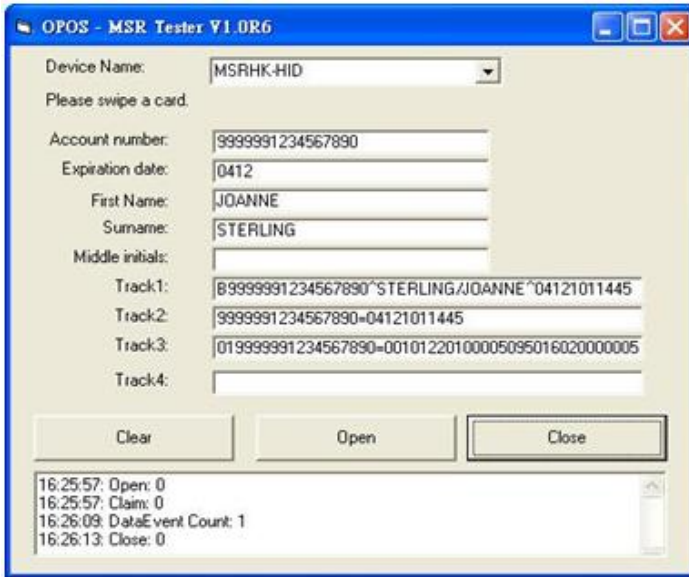

4.10 API

4.10.1 API Package Content

You can find the enclosed API Package files in the Protech Manual /Driver DVD. Depending on the machine types, the API Package may include the following files:

Function DLL			
Directory	Function	File Name	Description
ProxAPI standard\	Cash Drawer	Cash Drawer.dll	Driver to control Cash Drawer
	WDT	Watchdog.dll	Driver to control Watchdog
	Hardware Monitor	Hardware Monitor.dll	Driver to read hardware data
	multilangXML.dll		Driver to open XML file
	Initial.xml		XML file to initiate the API Package
	ProxAP.exe		API program executable file
	XML Files\Model Name*\Initial.xml		XML file for each model
	Version.ini		Version Information

Sample Program		
Directory	Contents / File Name	Description
DEMO PROJECT\	DEMO PROJECT\GPIO Sample Code	C# VB6 VB.net Source Code
	DEMO PROJECT\Digital Sample Code	C# VB6 VB.net Source Code
	DEMO PROJECT\Watchdog Sample Code	C# VB6 VB.net MFC Source Code

4.10.2 API Procedure

Take **VB2005 .NET** for example. Follow the instructions below to perform the API procedure:

Step 1. Declare a function. You may create a module in your project and fill in the function.

Example: Cash drawer

```
Declare Function GetCashDrawerStatus Lib CashDrawer.dll (ByVal num_drawer as short) As Boolean
```

```
Declare Function CashDrawerOpen Lib CashDrawer.dll (ByVal num_drawer as short) As Boolean
```

Step 2. Create a button to call API Function.

a.) Call Cash drawer open event:

```
Private Sub cash_btn1_Click (ByVal Sender As System.Object, ByVal e As System.EventArgs) Handles cash_btn1.Click  
CashDrawerOpen(1), "1" specifies the cash drawer 1 port  
CashDrawerOpen(2), "2" specifies the cash drawer 2 port  
Timer1.start
```

b.) Detect Cash drawer status:

A timer event can be created.

```
Private Sub Timer1_Tick (ByVal Sender As System.Object,ByVal e As System.EventArgs) Handles Timer1.Tick  
Dim Receive_Status1 as Boolean  
Dim Receive_Status2 as Boolean  
Receive_Status1 = CashDrawerOpen(&H1)  
If Receive_Status1 = true then  
Text1.text = "cash drawer1 open" 'enter text into textbox.  
Else  
Text1.text = "cash drawer1 close" 'enter text into textbox.  
End if  
=====
```

```
Receive_Status2 = CashDrawerOpen(&H2)  
If Receive_Status2 = true then  
Text2.text = "cash drawer2 open" 'enter text into textbox.  
Else  
Text2.text = "cash drawer2 close" 'enter text into textbox.  
End if  
=====
```

```
End sub
```

Sample Code

(1) VB Declaration Method

```
Declare Function GetCashDrawerStatus Lib CashDrawer.dll (ByVal  
num_drawer as short) As Boolean
```

```
Declare Function CashDrawerOpen Lib CashDrawer.dll (ByVal num_drawer as  
short) As Boolean
```

(2) Call Function

Open cash drawer:

```
CashDrawerOpen(1)
```

Open cash drawer1

```
CashDrawerOpen(2)
```

Open cash drawer2

Check cash drawer status:

```
Dim receive_status as Boolean
```

Check cash drawer1 status

```
Receive_Status = CashDrawerOpen(&H1)
```

Check cash drawer2 status

```
Receive_Status = CashDrawerOpen(&H2)
```

(1) C# Declaration Method

```
Public class PortAccess  
{  
[DllImport("CashDrawer.dll",EntryPoint = "Initial_CashDrawer")]  
Public static extern void Initial_CashDrawer();  
[DllImport("CashDrawer.dll",EntryPoint= "GetCashDrawerStatus")]  
Public static extern bool GetCashDrawerStatus()  
[DllImport("CashDrawer.dll",EntryPoint = "CashDrawerOpen")]  
Public static extern bool CashDrawerOpen(short num_drawer);} 
```

(2) Call Function

Open cash drawer1

```
PortAccess.CashDrawerOpen(0x01); //check cash drawer1 status
```

Open cash drawer2

```
PortAccess.CashDrawerOpen(0x02); //check cash drawer2 status
```

```
Bool bstatus;
```

```
bstatus = PortAccess.GetCashDrawerStatus(0x01);
```

bstatus = PortAccess.GetCashDrawerStatus(0x02); //Before get cash drawer status, need to initial cash drawer first

VB.NET external function:

Declare Function SetMinSec Lib "WatchDog.dll" (ByVal kind As Short,ByVal delay_time As Short) As Boolean

Declare Function Stopwatchdog Lib "WatchDog.dll" () As Short

Declare Function Setwatchdog Lib "WatchDog.dll" (ByVal value As Short) As Boolean

Declare Function Digital_Initial Lib "Digital.dll" () As Long

Declare Function Digital_Set Lib "Digital.dll"(ByVal hex_value As Short) As Long

Declare Function Digital_Get Lib "Digital.dll" () As Short

Declare Function GPIO_Initial Lib "GPIO.dll" () As Long

Declare Function GPIO_SetPort Lib "GPIO.dll"(ByVal direct As long)

Declare Function GPIO_Set Lib "GPIO.dll"(ByVal dout_value As long) As Boolean

Declare Function GPIO_Get Lib "GPIO.dll"() As Short

Declare Function GetCashDrawerStatus Lib CashDrawer.dll (ByVal num_drawer as short) As Boolean

Declare Function CashDrawerOpen Lib CashDrawer.dll (ByVal num_drawer as short) As Boolean

VB 6 external function:

Declare Function CashDrawerOpen Lib "CashDrawer.dll" (ByVal num_drawer As Integer) As Boolean

Declare Function GetCashDrawerStatus Lib "CashDrawer.dll" (ByVal num_drawer As Integer) As Boolean

Note: VB.net short = integer VB6

4.10.3 Cash Drawer

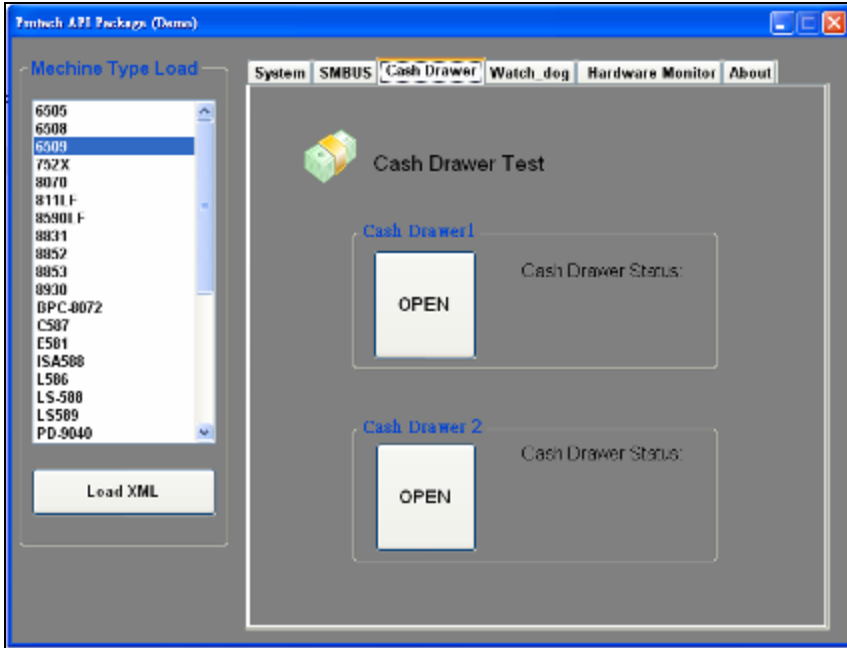

Button/Item	Description
OPEN (button)	Tap to open the cash drawer.
Cash Drawer Status	<p>Cash drawer status will be displayed after OPEN is tapped.</p> <ul style="list-style-type: none"> • Cash Drawer is closed when the following picture is shown: <div data-bbox="559 1090 771 1201" style="border: 1px solid black; padding: 5px; margin: 10px 0;"> <p>Cash Drawer Status:</p> <p style="text-align: center;">Close</p> </div> • Cash Drawer is opened when the following picture is shown: <div data-bbox="559 1315 771 1426" style="border: 1px solid black; padding: 5px; margin: 10px 0;"> <p>Cash Drawer Status:</p> <p style="text-align: center;">Open</p> </div>

4.10.4 Watchdog

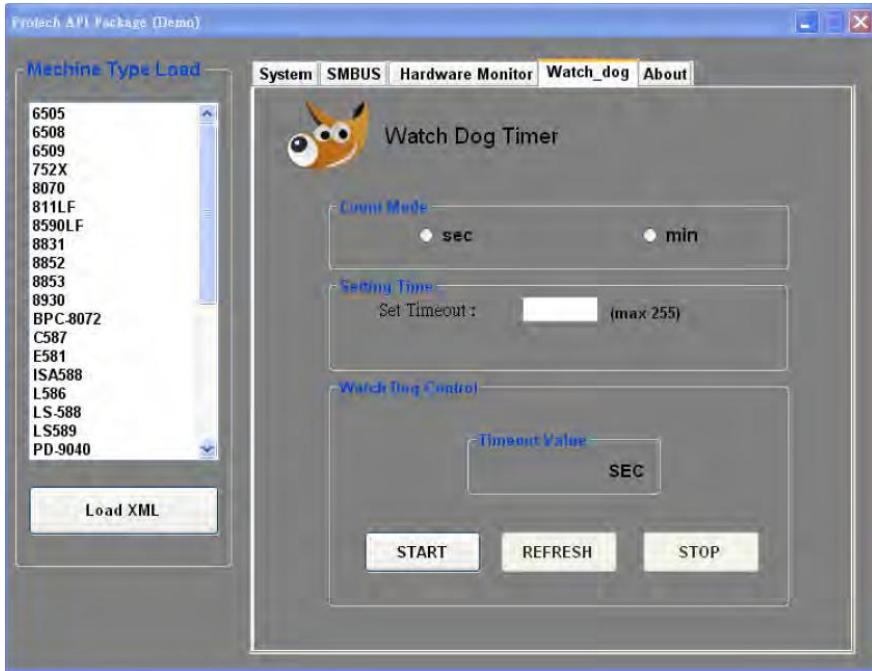

Button/Item	Description
Count Mode (radio button)	Select second or minute as the time unit of the watchdog timer.
Setting Time	Set the timeout for the watchdog timer. (Maximum value: 255 seconds or minutes)
Watch Dog Control	<ul style="list-style-type: none"> • Timeout Value: Simulation timer of the API program. The running watchdog timeout will be displayed (in seconds). It is not as accurate as a hardware watchdog clock. • START: Tap to start the watchdog timer. Meanwhile, the REFRESH and STOP buttons will be enabled. • STOP: Tap to stop the watchdog timer. • REFRESH: Tap to restart the watchdog timer.

4.11 API Function

The API program-related sample programs, developed in VB.Net and C#, are provided for easy use of the API Package. Refer to the main API functions listed as below:

API Function		DLL	
Cash Drawer	CashDrawerOpen GetCashDrawerStatus	multilangXML.dll	CashDrawer.dll
Watchdog (WD)	Watchdog_Set Watchdog_Stop Watchdog_SetMinSec Watchdog_Recount		WatchDog.dll
Hardware Monitor	HMWVoltage_Get HMWTemperature_Get HMWFanSpeed_Get		Hardware Monitor.dll

4.11.1 Cash Drawer Function

CashDrawerOpen

```
bool CashDrawerOpen (short num_drawer);
```

Purpose: Open the cash drawer API.
 Value: num_drawer = 1 (Open the Cash Drawer1)
 num_drawer = 2 (Open the Cash Drawer2)
 Return: True (1) on success, False (0) on failure

Example: CashDrawerOpen(0x01); // Open the Cash Drawer1

GetCashDrawerStatus

```
bool GetCashDrawerStatus (short num_drawer);
```

Purpose: Get the cash drawer status.
 Value: num_drawer = 1 (Get the Cash Drawer1 status)
 num_drawer = 2 (Get the Cash Drawer2 status)
 Return: True (1) on success, False (0) on failure

Example: Short data;
 data= GetCashDrawerStatus(0x01); // Get the Cash Drawer1 status

```
if (data)
  MsgBox("open1"); // Cash Drawer1 status
  "Open"
Else
  MsgBox("close1"); // Cash Drawer1 status
  "Close"
Endif
```

4.11.2 Watch Dog Function

Watchdog_Set

bool Watchdog_Set (int value);

Purpose: Set the timeout for the watchdog timer.
Value value = 0 ~ 255
Return: True (1) on success, False (0) on failure

Watchdog_SetMinSec

bool Watchdog_SetMinSec (int kind);

Purpose: Set the unit of time as second/minute
Value kind = 1 (Measured in unit of second)
2 (Measured in unit of minute)
Return: True (1) on success, False (0) on failure

Watchdog_Stop

bool Watchdog_Stop (void);

Purpose: Stop the watchdog timer
Value None
Return: True (1) on success, False (0) on failure

Watchdog_Recount

bool Watchdog_Recount (void);

Purpose: Restart the watchdog timer
Value None
Return: True (1) on success, False (0) on failure

5 BIOS SETUP

This chapter guides users how to configure the basic system configurations via the BIOS Setup Utilities. The information of the system configuration is saved in battery-backed CMOS RAM and BIOS NVRAM so that the Setup information is retained when the system is powered off. The BIOS Setup Utilities consist of the following menu items:

- Accessing Setup Utilities
- Main Menu
- Advanced Menu
- Chipset Menu
- Security Menu
- Boot Menu
- Save & Exit Menu

5.1 Introduction

The PA-3222 System uses an AMI (American Megatrends Incorporated) Aptio BIOS that is stored in the Serial Peripheral Interface Flash Memory (SPI Flash) and can be updated. The SPI Flash contains the built-in BIOS setup program, Power-On Self-Test (POST), PCI auto-configuration utility, LAN EEPROM information, and Plug and Play support.

Aptio is AMI's BIOS firmware based on the UEFI (Unified Extensible Firmware Interface) specifications and the Intel Platform Innovation Framework for EFI. The UEFI specification defines an interface between the operating system and platform firmware. The interface consists of data tables that contain platform-related information, boot service calls, and runtime service calls that are available to the operating system and its loader. These elements have combined to provide a standard environment for booting the operating system and running pre-boot applications.

The diagram below shows the Extensible Firmware Interface's location in the software stack.

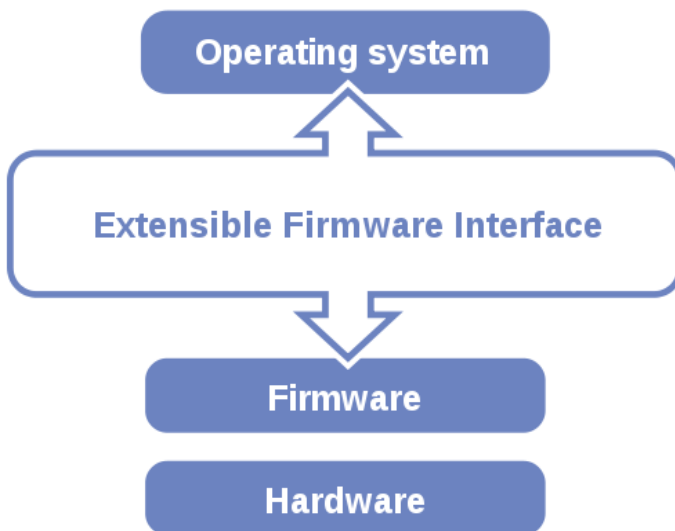

Figure 5-1. Extensible Firmware Interface Diagram

EFI BIOS provides an user interface that allows you to modify hardware configuration, e.g. change the system date and time, enable/disable a system component, determine bootable device priority, set up personal password, etc., which is convenient for engineers to perform modifications and customize the computer system and allows technicians to troubleshoot the occurred errors when the hardware is faulty.

The BIOS setup menu allows users to view and modify the BIOS settings for the computer. After the system is powered on, users can access the BIOS setup menu by pressing or <Esc> immediately while the POST message is running before the operating system is loading.

All the menu settings are described in details in this chapter.

5.2 Accessing Setup Utility

After the system is powered on, BIOS will enter the Power-On Self-Test (POST) routines and the POST message will be displayed:

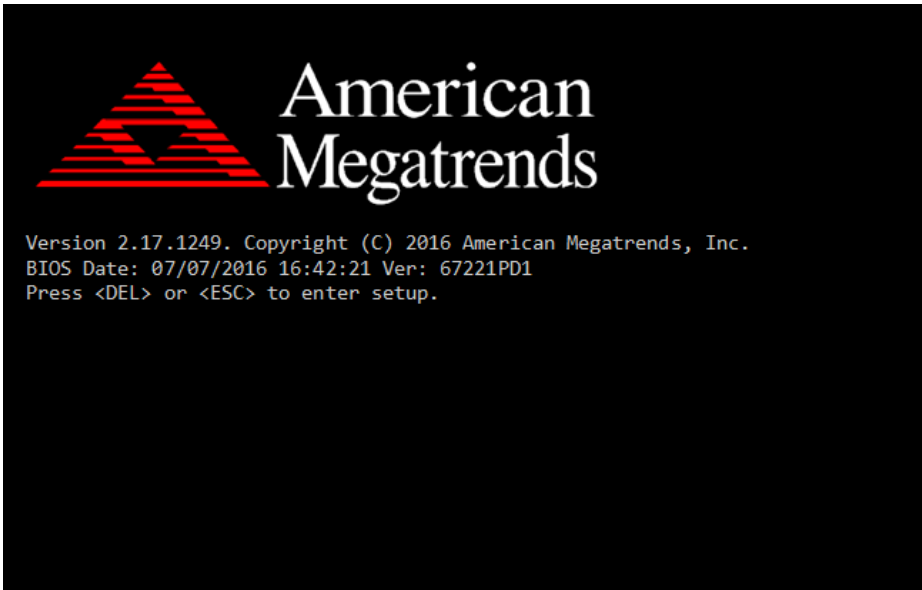
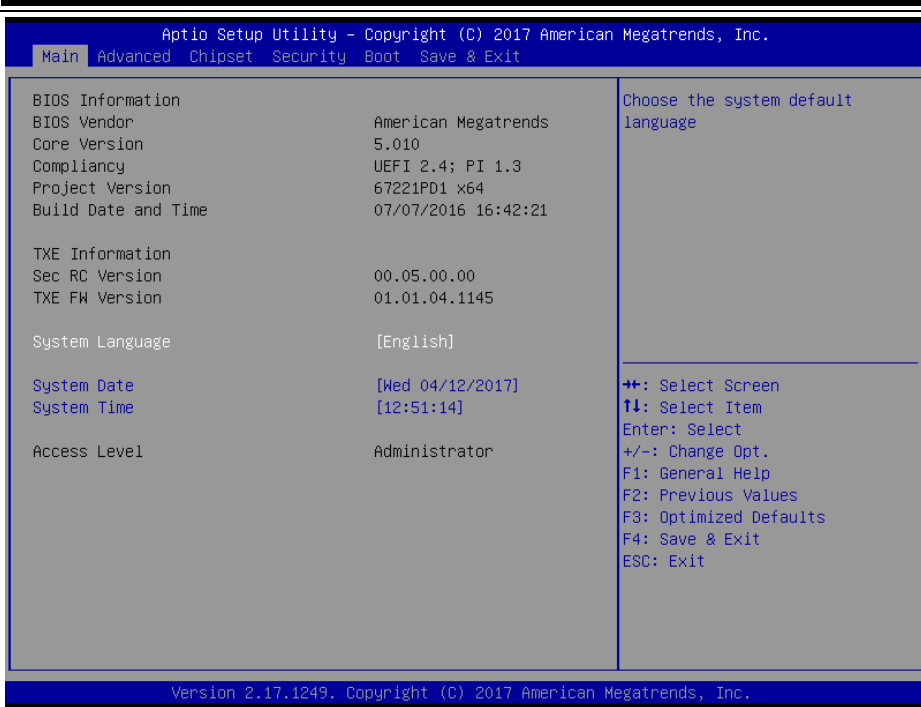

Figure 5-2. POST Screen with AMI Logo

Press **** or **<Esc>** to access the Setup Utility program and the **Main** menu of the Aptio Setup Utility will appear on the screen as below:



BIOS Setup Menu Initialization Screen

You may move the cursor by <↑> and <↓> keys to highlight the individual menu items. As you highlight each item, a brief description of the highlighted selection will appear on the right side of the screen.

The language of the BIOS setup menu interface and help messages are shown in US English. You may use <↑> or <↓> key to select among the items and press <Enter> to confirm and enter the sub-menu. The following table provides the list of the navigation keys that you can use while operating the BIOS setup menu.

BIOS Setup Navigation Key	Description
<←> and <→>	Select a different menu screen (move the cursor from the selected menu to the left or right).
<↑> and <↓>	Select a different item (move the cursor from the selected item upwards or downwards)
<Enter>	Execute the command or select the sub-menu.
<F2>	Load the previous configuration values.
<F3>	Load the default configuration values.
<F4>	Save the current values and exit the BIOS setup menu.
<Esc>	Close the sub-menu. Trigger the confirmation to exit BIOS setup menu.

BIOS Messages

This section describes the alert messages generated by the board's BIOS. These messages would be shown on the monitor when certain recoverable errors/events occur during the POST stage. The table below gives an explanation of the BIOS alert messages:

BIOS Message	Explanation
A first boot or NVRAM reset condition has been detected.	BIOS has been updated or the battery was replaced.
The CMOS defaults were loaded.	Default values have been loaded after the BIOS was updated or the battery was replaced.
The CMOS battery is bad or has been recently replaced.	The battery may be losing power and users should replace the battery immediately. Also, this message is displayed once the new battery is replaced.

5.3 Main

Menu Path *Main*

The **Main** menu allows you to view the BIOS Information, change the system date and time, and view the user access privilege level. Use tab to switch between date elements. Use <↑> or <↓> arrow keys to highlight the item and enter the value you want in each item. This screen also displays the BIOS version (project) and BIOS Build Date and Time.

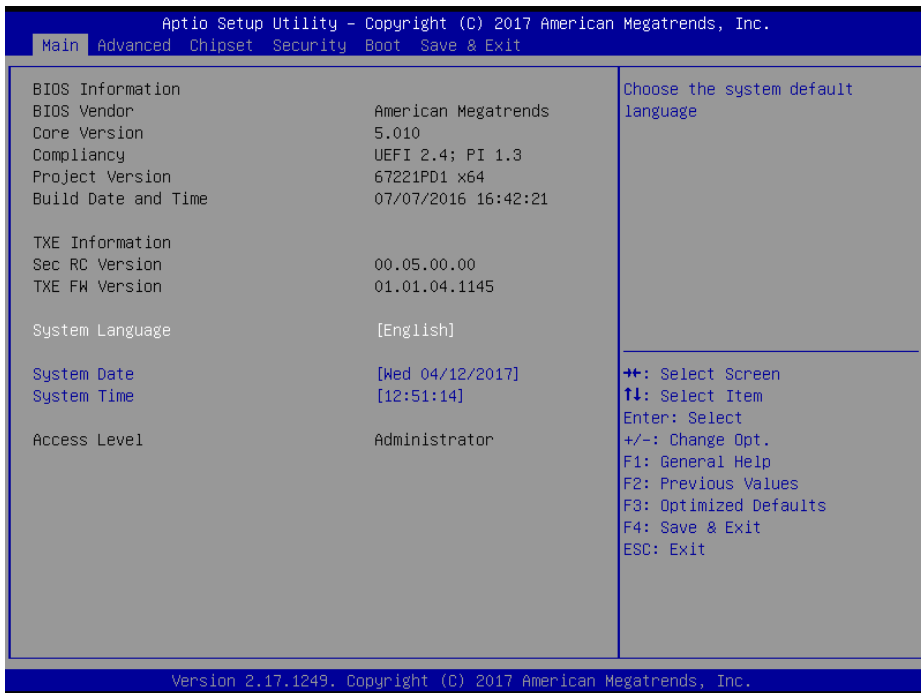

Main Screen

BIOS Setting	Options	Description/Purpose
BIOS Vendor	No changeable options	Displays the name of the BIOS vendor.
Core Version	No changeable options	Displays the current BIOS core version.
Compliance	No changeable options	Displays the current UEFI version.
Project Version	No changeable options	Displays the version of the BIOS currently installed on the platform.
Build Date and Time	No changeable options	Displays the date that the current BIOS version is built.
Sec RC Version	No changeable options	Displays the current Sec RC version.
TXE FW Version	No changeable options	Displays the current TXE Version

BIOS Setting	Options	Description/Purpose
System Language	English	BIOS Setup language.
System Date	Month, day, year	Sets the system date. The format is [Day Month/ Date/ Year]. Users can directly enter values or use <+> or <-> arrow keys to increase/decrease it. The "Day" is automatically changed.
System Time	Hour, minute, second	Sets the system time. The format is [Hour: Minute: Second]. Users can directly enter values or use <+> or <-> arrow keys to increase/decrease it.

5.4 Advanced

Menu Path *Advanced*

This menu provides advanced configurations such as ACPI Settings, F81866 Super IO Configuration, Hardware Monitor, F81866 Watchdog, CPU Configuration, IDE Configuration, OS Selection, CSM Configuration and USB Configuration.



Advanced Menu Screen

BIOS Setting	Options	Description/Purpose
ACPI Settings	Sub-Menu	System ACPI Parameters.
F81866 Super IO Configuration	Sub-Menu	System Super IO Chip Parameters
Hardware Monitor	Sub-Menu	Monitor hardware status
F81866 Watchdog	Sub-Menu	F81866 Watchdog Parameters.
CPU Configuration	Sub-Menu	CPU Configuration. Parameters.
IDE Configuration	Sub-Menu	SATA Configuration Parameters.
OS Selection	Sub-Menu	OS Selection
CSM Configuration	Sub-Menu	Configures Option ROM execution, boot options filters, etc.
USB Configuration	Sub-Menu	USB Configuration Parameters.

5.4.1 Advanced – ACPI Settings

Menu Path *Advanced > ACPI Settings*

The **ACPI Settings** allows users to configure relevant ACPI (Advanced Configuration and Power Management Interface) settings, such as Enable Hibernation.



ACPI Settings Screen

BIOS Setting	Options	Description/Purpose
Enable Hibernation	- Disabled - Enabled	Enables or Disables System ability to Hibernate (OS/S4 Sleep State). This option may be not effective with some OS.

5.4.2 Advanced – F81866 Super IO Configuration

Menu Path *Advanced > F81866 Super IO Configuration*

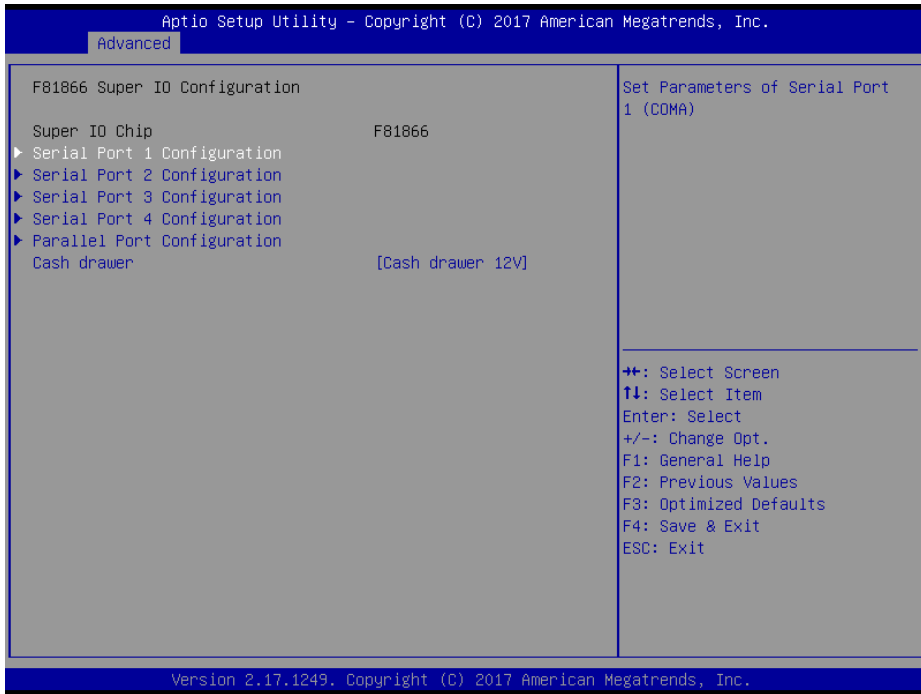

F81866 Super IO Configuration Screen

BIOS Setting	Options	Description/Purpose
Serial Port 1 Configuration	Sub-menu	Sets the parameters of Serial Port 1 (COMA).
Serial Port 2 Configuration	Sub-menu	Sets the parameters of Serial Port 2 (COMB).
Serial Port 3 Configuration	Sub-menu	Sets the parameters of Serial Port 3 (COMC).
Serial Port 4 Configuration	Sub-menu	Sets the parameters of Serial Port 4 (COMD).
Parallel Port Configuration	Sub-menu	Sets Parameters of Parallel Port (LPT/LPTE).
Cash drawer	- Cash Drawer 12V - Cash Drawer 24V	Cash Drawer select 12V or 24V.

Menu Path *Advanced > F81866 Super IO Configuration > Serial Port 1 Configuration*

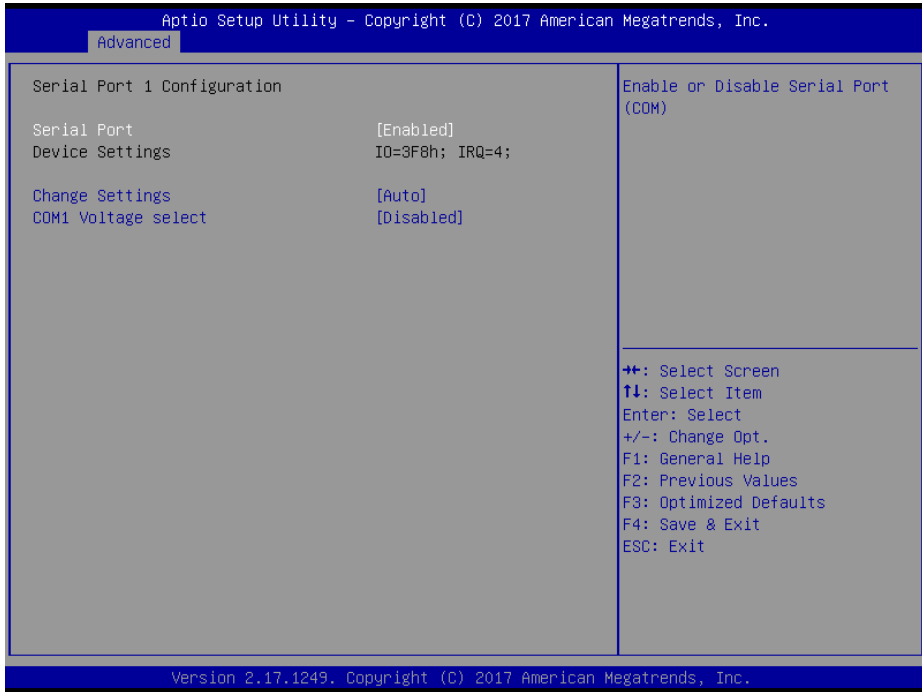

Serial Port 1 Configuration Screen

BIOS Setting	Options	Description/Purpose
Serial Port	- Disabled - Enabled	Enable or Disable Serial Port 1.
Device settings	No changeable options	Displays the current settings of Serial Port 1.
Change Settings	- Auto - IO=3F8h; IRQ=4; - IO=3F8h; IRQ=3,4,5,6,7,9,10,11,12; - IO=2F8h; IRQ=3,4,5,6,7,9,10,11,12; - IO=3E8h; IRQ=3,4,5,6,7,9,10,11,12; - IO=2E8h; IRQ=3,4,5,6,7,9,10,11,12;	Selects IRQ and I/O resource settings for the Serial Port 1.
COM1 Voltage select	- Disabled - 12V - 5V	Disables or selects COM1 Voltage 12V/5V.

Menu Path *Advanced > F81866 Super IO Configuration >
Serial Port 2 Configuration*

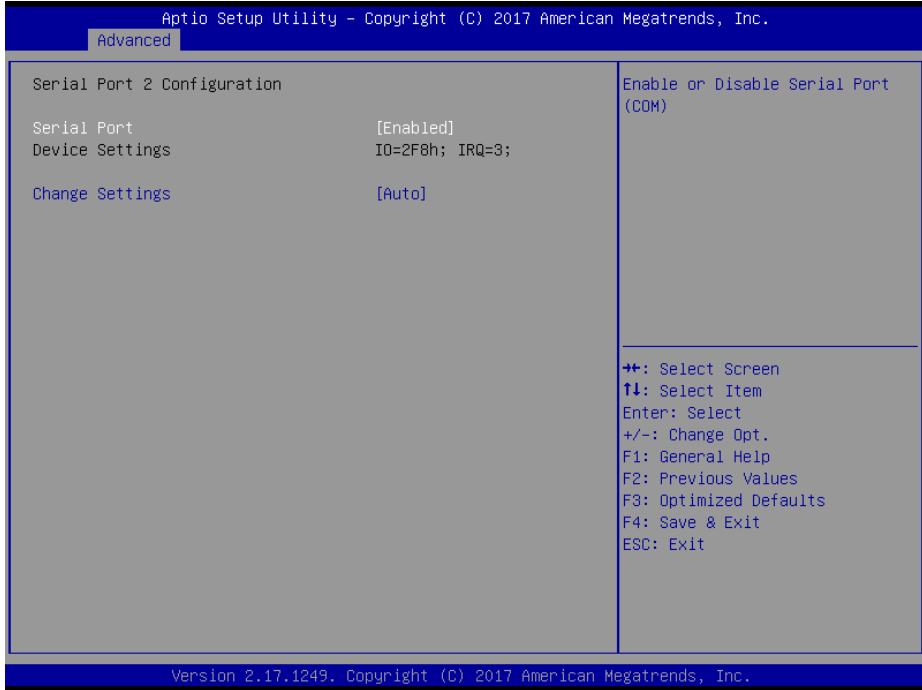

Serial Port 2 Configuration Screen

BIOS Setting	Options	Description/Purpose
Serial Port	- Disabled - Enabled	Enables or Disables Serial Port 2.
Device Settings	No changeable options	Displays the current settings of Serial Port 2.
Change Settings	- Auto - IO=2F8h; IRQ=3; - IO=3F8h; IRQ=3,4,5,6,7,9,10,11,12; - IO=2F8h; IRQ=3,4,5,6,7,9,10,11,12; - IO=3E8h; IRQ=3,4,5,6,7,9,10,11,12; - IO=2E8h; IRQ=3,4,5,6,7,9,10,11,12;	Selects IRQ and I/O resource settings for the Serial Port 2.

Menu Path *Advanced > F81866 Super IO Configuration > Serial Port 3 Configuration*



Serial Port 3 Configuration Screen

BIOS Setting	Options	Description/Purpose
Serial Port	- Disabled - Enabled	Enables or Disables Serial Port 3.
Device Settings	No changeable options	Displays the current settings of Serial Port 3.
Change Settings	- Auto - IO=3E8h; IRQ=7; - IO=3E8h; IRQ=3,4,5,6,7,9,10,11,12; - IO=2E8h; IRQ=3,4,5,6,7,9,10,11,12; - IO=2F0h; IRQ=3,4,5,6,7,9,10,11,12; - IO=2E0h; IRQ=3,4,5,6,7,9,10,11,12;	Selects IRQ and I/O resource settings for the Serial Port 3.

Menu Path *Advanced > F81866 Super IO Configuration > Serial Port 4 Configuration*

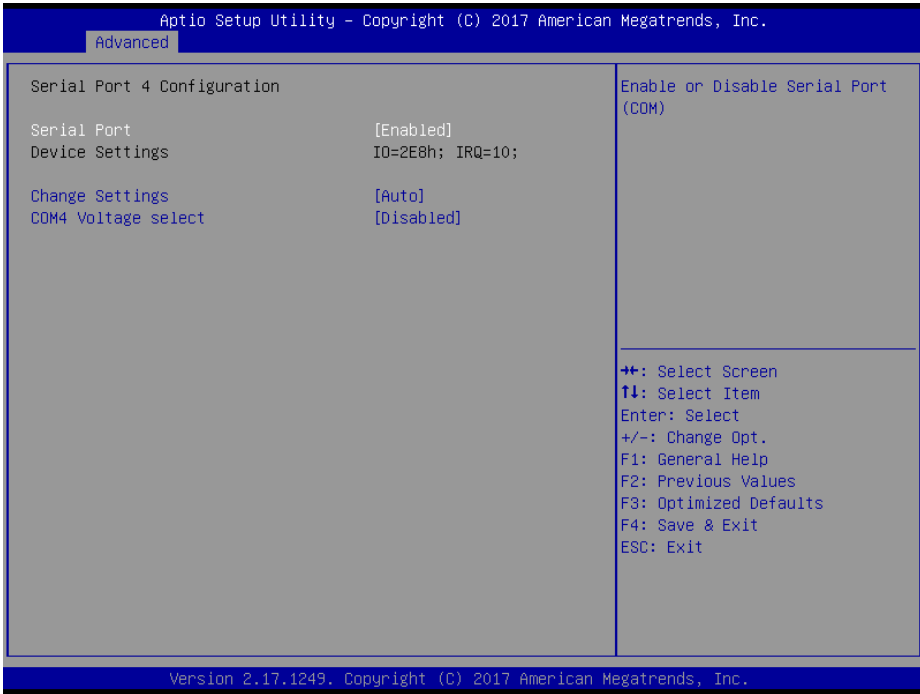

Serial Port 4 Configuration Screen

BIOS Setting	Options	Description/Purpose
Serial Port	- Disabled - Enabled	Enables or Disables Serial Port 4.
Device Settings	No changeable options	Displays the current settings of Serial Port 4.
Change Settings	- Auto - IO=2E8h; IRQ=10; - IO=3E8h; IRQ=3,4,5,6,7,9,10,11,12; - IO=2E8h; IRQ=3,4,5,6,7,9,10,11,12; - IO=2F0h; IRQ=3,4,5,6,7,9,10,11,12; - IO=2E0h; IRQ=3,4,5,6,7,9,10,11,12;	Selects IRQ and I/O resource settings for the Serial Port 4.
COM4 Voltage select	- Disabled - 12V - 5V	Disables or selects COM4 Voltage 12V/5V.

Menu Path *Advanced > F81866 Super IO Configuration > Parallel Port Configuration*

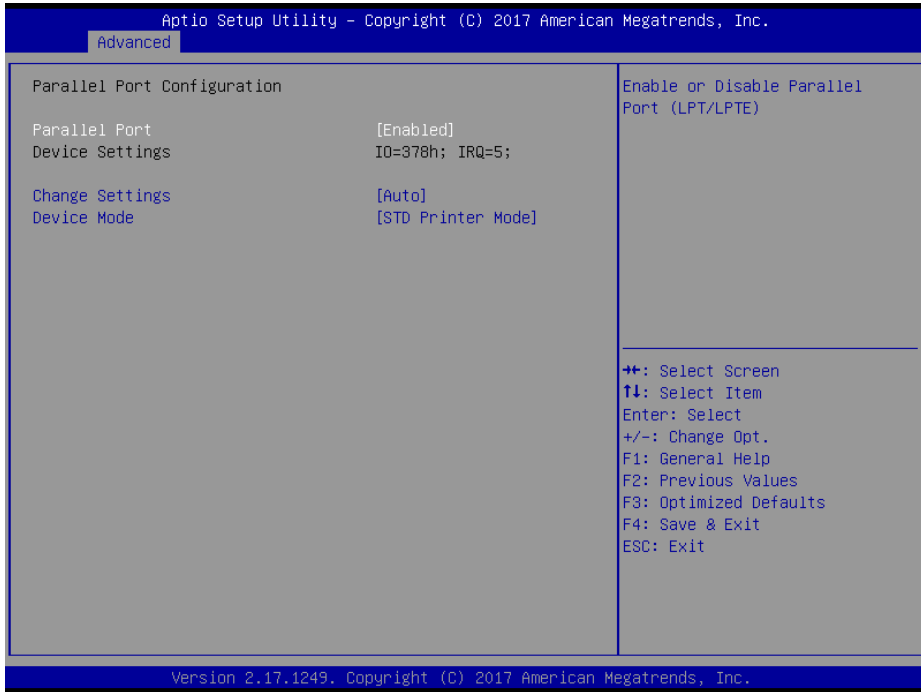

Parallel Port Configuration Screen

BIOS Setting	Options	Description/Purpose
Parallel Port	- Disabled - Enabled	Enables or Disables Parallel Port.
Device Settings	No changeable options	Displays the current settings of Parallel Port.
Change Settings	- Auto - IO=378h; IRQ=5 - IO=378h; IRQ=5,6,7,9,10,11,12 - IO=278h; IRQ=5,6,7,9,10,11,12 - IO=3BCh; IRQ=5,6,7,9,10,11,12	Selects IRQ and I/O resource settings for the parallel port.
Mode	- STD Printer Mode - SPP Mode - EPP-1.9 and SPP Mode - EPP-1.7 and SPP Mode - ECP Mode - ECP and EPP 1.9 Mode - ECP and EPP 1.7 Mode	Changes the printer port mode.

5.4.3 Advanced – Hardware Monitor

Menu Path *Advanced > Hardware Monitor*

The **Hardware Monitor** allows users to monitor the health and status of the system such as CPU temperature, system temperature and voltage levels in supply.

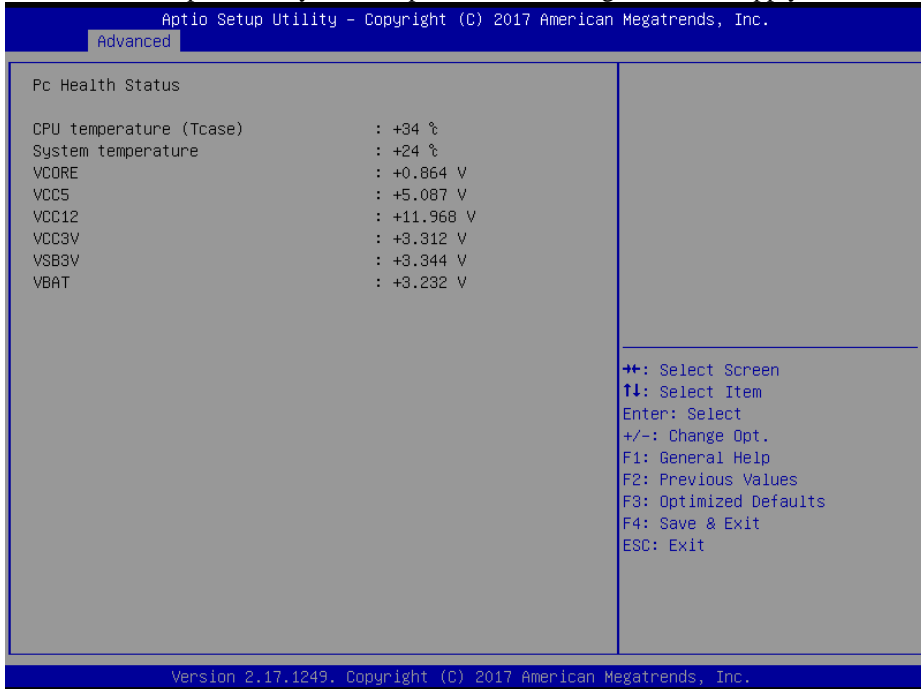

Hardware Monitor Screen

BIOS Setting	Options	Description/Purpose
CPU Temperature (Tcase)	No changeable options	Displays the processor's temperature.
System Temperature	No changeable options	Displays the system's temperature.
VCORE	No changeable options	Detects and displays the VCORE CPU voltage.
VCC5	No changeable options	Detects and displays 5V voltage.
VCC12	No changeable options	Detects and displays 12V voltage.
VCC3V	No changeable options	Detects and displays 3V voltage.
VSB3V	No changeable options	Detects and displays VSB3V voltage.
VBAT	No changeable options	Detects and displays the battery voltage.

5.4.4 Advanced – F81866 Watchdog Configuration

Menu Path *Advanced > F81866 Watchdog*

If the system hangs or fails to respond, enable the F81866 watchdog function to trigger a system reset via the 255-level watchdog timer.

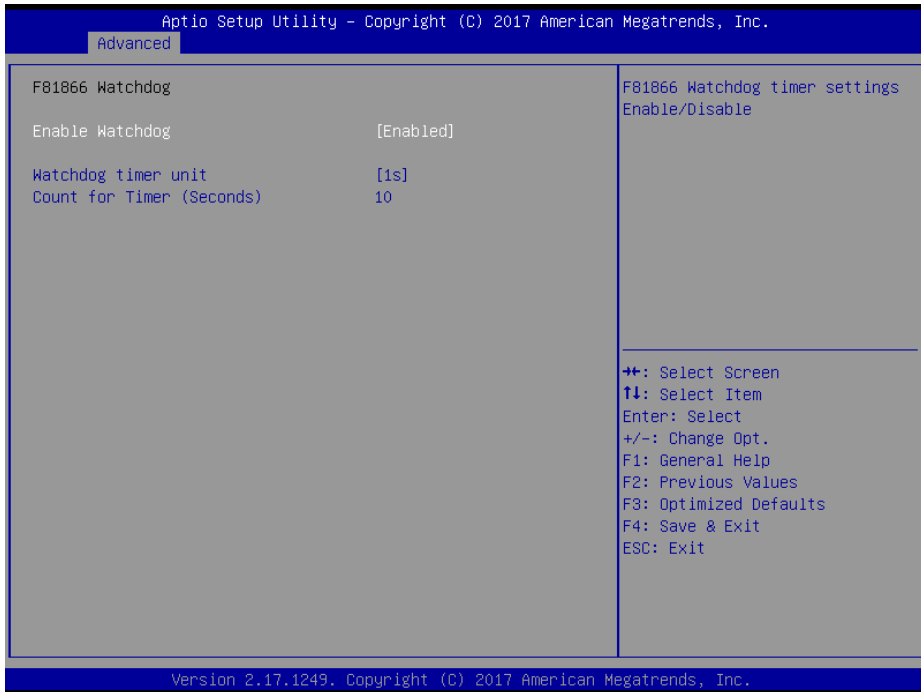

F81866 Watchdog Configuration Screen

BIOS Setting	Options	Description/Purpose
Enable Watchdog	- Enabled - Disabled	Enables/Disables F81866 Watchdog timer settings.
Watchdog timer unit	- 1s - 60s	Selects 1s (second) or 60s (minute) as the time unit of Watchdog timer.
Count for Timer (Seconds)	Numeric (from 1 to 255)	Sets the timeout for Watchdog timer. (Max. value: 255 seconds or minutes)

5.4.5 Advanced – CPU Configuration

Menu Path *Advanced > CPU Configuration*

The **CPU Configuration** provides advanced CPU settings and some information about CPU.



CPU Configuration Screen

BIOS Setting	Options	Description/Purpose
Socket 0 CPU Information	Sub-Menu	Reports CPU Information
CPU Speed	No changeable options	Displays the CPU speed.
64-bit	No changeable options	Reports if the processor supports Intel x86-64 (amd64) implementation.

5.4.6 Advanced – CPU Configuration > Socket 0 CPU Information

Menu Path *Advanced > CPU Configuration > Socket 0 CPU Information*

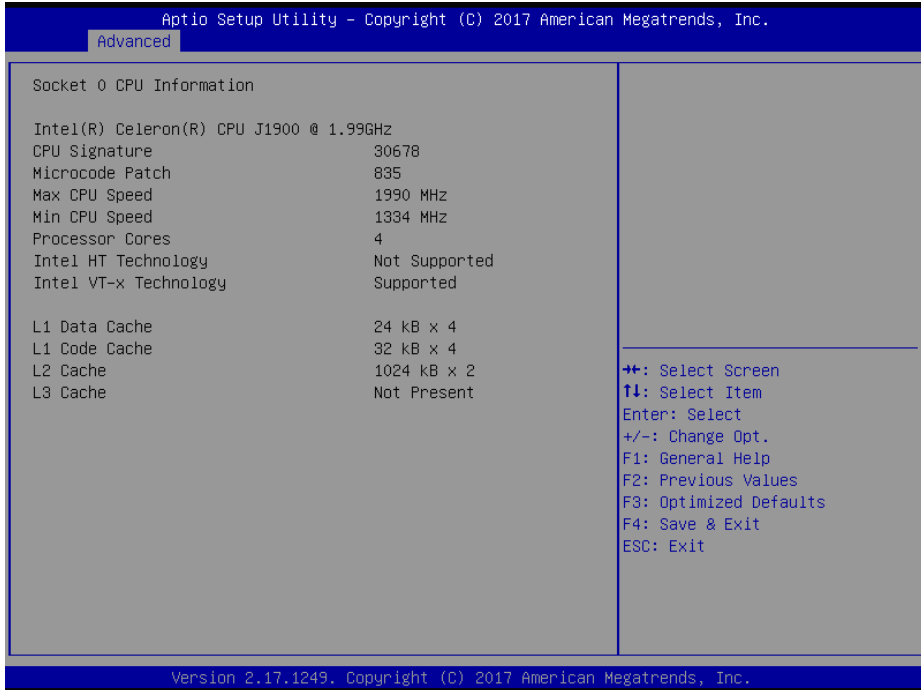

Socket 0 CPU Information Screen

BIOS Setting	Options	Description/Purpose
CPU Signature	No changeable options	Reports the CPU Signature
Microcode Patch	No changeable options	Reports the CPU Microcode Patch Version.
Max CPU Speed	No changeable options	Reports the maximum CPU Speed.
Min CPU Speed	No changeable options	Reports the minimum CPU Speed
Processor Cores	No changeable options	Displays number of physical cores in processor.
Intel HT Technology	No changeable options	Reports if Intel Hyper-Threading Technology is supported by processor. Hyper Threading is Intel's term for its simultaneous multithreading implementation in their CPUs. Enable this function will improve parallelization of

BIOS Setting	Options	Description/Purpose
		computation performed on PC microprocessor. For each processor core that is physically present, the operating system addresses two virtual processors, and shares the workload between them when possible.
Intel VT-x Technology	No changeable options	Reports if Intel VT-x Technology is supported by the processor. VMM can utilize the additional hardware capabilities provided by Vanderpool Technology. Previously codenamed "Vanderpool", VT-x represents Intel's technology for virtualization on the x86 platform.
L1 Data Cache	No changeable options	Displays the size of L1 Data Cache.
L1 Code Cache	No changeable options	Displays the size of L1 Code Cache.
L2 Cache	No changeable options	Displays the size of L2 Cache.
L3 Cache	No changeable options	Displays the size of L3 Cache.

5.4.7 Advanced – IDE Configuration (AHCI Mode)

Menu Path *Advanced > IDE Configuration*

The **IDE Configuration** allows users to enable / disable the SATA controller as well as the operational mode after the SATA controller is enabled. The following screen indicates the functions available when the SATA hard drive is set to work in AHCI mode.

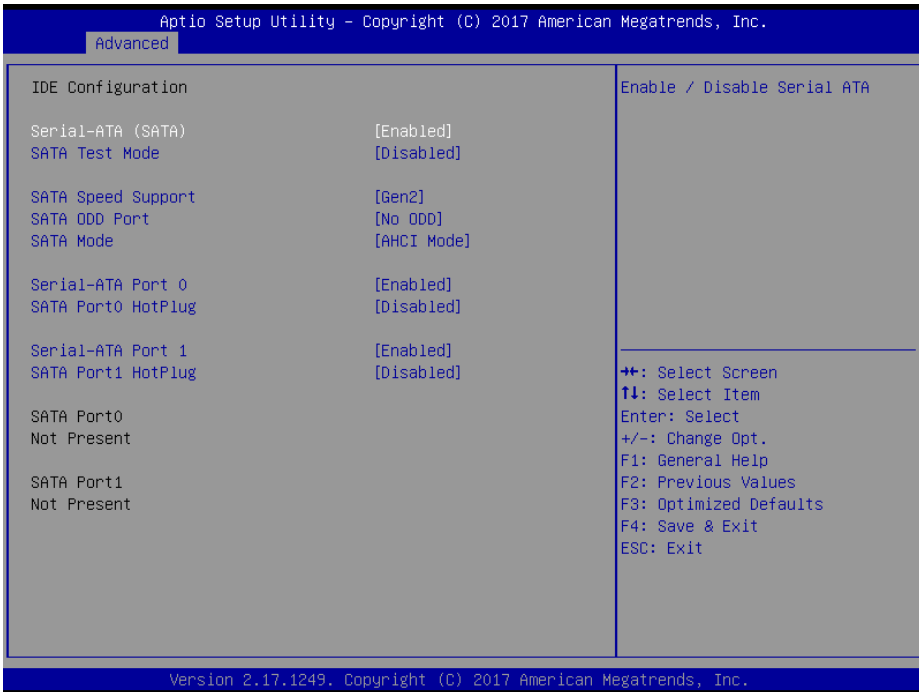

IDE Configuration Screen – AHCI Mode

BIOS Setting	Options	Description/Purpose
SATA Controller(s)	- Disabled - Enabled	Enables or Disables the on-chip SATA Device. Default: Enabled.
SATA Test Mode	- Disabled - Enabled	Enables or disables SATA Test Mode.
SATA Speed Support	- GEN1 - GEN2	Gen1 mode sets the device to 1.5 Gbit/s speed. Gen2 mode sets the device to 3 Gbit/s speed (in case it is compatible).
SATA ODD Port	- Port0 ODD - Port1 ODD	SATA ODD is Port0 or Port1

BIOS Setting	Options	Description/Purpose
	- No ODD	
SATA Mode	- IDE mode - AHCI mode	Configures SATA as follows: <ul style="list-style-type: none"> • IDE: Sets SATA operation mode to IDE mode. • AHCI: SATA works as AHCI (Advanced Host Controller Interface) mode for achieving better performance.
SATA Port 0	- Disabled - Enabled	Enables or disables SATA port 0 device.
SATA Port 0 HotPlug	- Disabled - Enabled	Enables or Disables Hot Plug function to designate SATA port 0 as hot-pluggable.
SATA Port 1	- Disabled - Enabled	Enables or disables SATA port 1 Device.
SATA Port 1 HotPlug	- Disabled - Enabled	Enables or Disables Hot Plug function to designate SATA port 1 as hot-pluggable.
SATA Port 0	[drive]	Displays the drive installed on the SATA port 0. Shows [Empty] if no drive is installed.
SATA Port 1	[drive]	Displays the drive installed on the SATA port 1. Shows [Empty] if no drive is installed.

5.4.8 Advanced – OS Selection

Menu Path *Advanced > OS Selection*

The **OS Selection** allows users to select the operating system from Windows 7 or Windows 8.x &10.

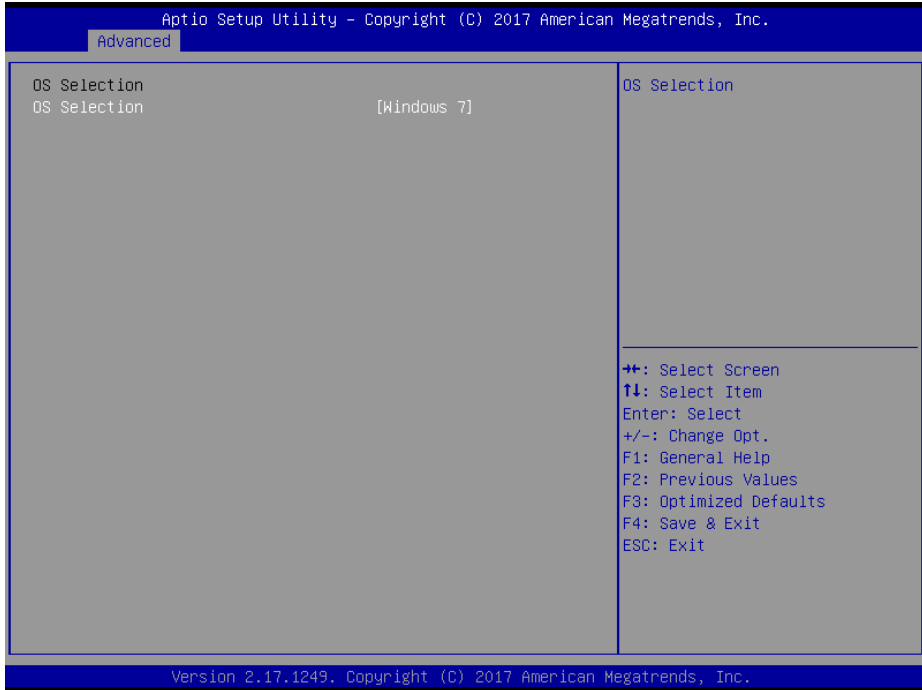

OS Selection Screen

BIOS Setting	Options	Description/Purpose
OS Selection	- Windows 7 - Windows 8.x & 10	OS Selection

5.4.9 Advanced – CSM Configuration

Menu Path *Advanced > CSM Configuration*

The **CSM Configuration** provides advanced CSM (Compatibility Support Module) configurations such as Enable/Disable CSM Support, configure Option ROM execution, boot option filter, etc.

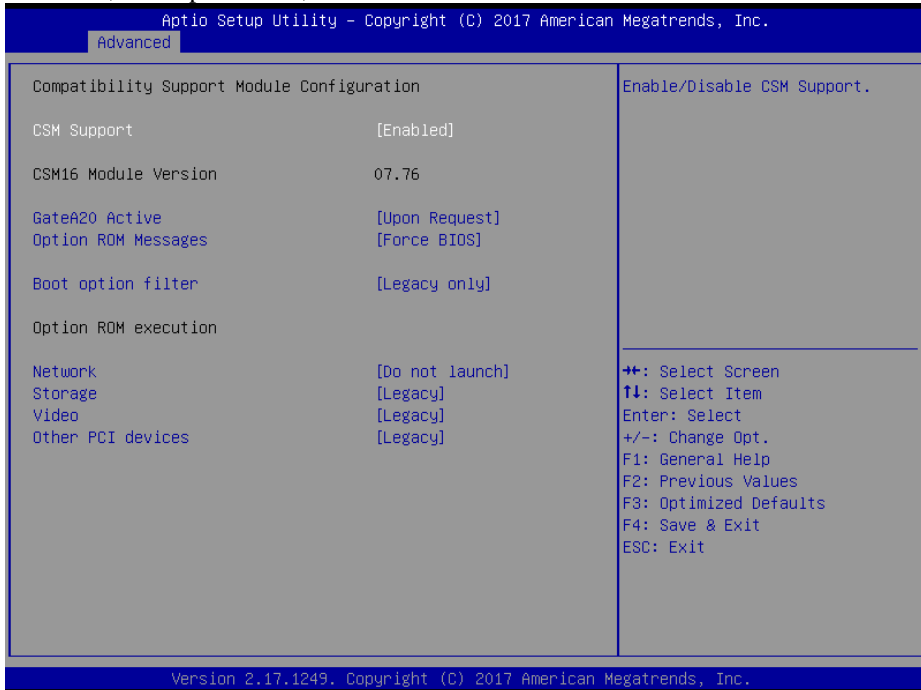

CSM Configuration Screen

BIOS Setting	Options	Description/Purpose
CSM Support	- Disabled - Enabled	Disables or Enables CSM support.
CSM16 Module Version	No changeable options	Displays the current CSM (Compatibility Support Module) version.
GateA20 Active	- Upon Request - Always	Selects Gate A20 operation mode: <ul style="list-style-type: none"> • UPON REQUEST: GA20 can be disabled using BIOS services. • ALWAYS: Do not allow disabling GA20; this option is useful when any RT code is executed above 1MB.
Option ROM Messages	- Force BIOS - Keep Current	Configures the display mode for Option ROM messages.

BIOS Setting	Options	Description/Purpose
Boot option filter	- UEFI and Legacy - Legacy only - UEFI only	This option controls what kind of devices system can boot.
Network	- Do not launch - Legacy	Controls the execution of UEFI or Legacy PXE
Storage	- Do not launch - UEFI - Legacy	Controls the execution of UEFI or Legacy Storage
Video	- Do not launch - UEFI - Legacy	Controls the execution of UEFI and Legacy Video.
Other PCI devices	- Do not launch - UEFI - Legacy	Selects launch method for other PCI devices, such as NIC, mass storage or video card.

5.4.10 Advanced – USB Configuration

Menu Path *Advanced > USB Configuration*

The **USB Configuration** allows users to configure advanced USB settings such as Legacy USB support.



USB Configuration Screen

BIOS Setting	Options	Description/Purpose
USB Devices	No changeable options	Displays number of available USB devices.
Legacy USB Support	- Disabled - Enabled - Auto	Enables support for legacy USB.
XHCI Hand-off	- Disabled - Enabled	This is a workaround for OSeS w/o XHCI hand-off support.
EHCI Hand-off	- Disabled - Enabled	This is a workaround for OSeS w/o EHCI hand-off support.
USB Mass Storage Driver Support	- Disabled - Enabled	Enable/Disable USB mass storage driver support.
USB transfer time-out	1 / 5 / 10 / 20 sec	The time-out value for Control, Bulk, and Interrupt transfers.

BIOS Setting	Options	Description/Purpose
Device reset time-out	10 / 20 / 30 / 40 sec	USB mass storage device Start Unit command time-out.
Device power-up delay	- Auto - Manual	Maximum time the device will take before it properly reports itself to the Host Controller. 'Auto' uses default value: for a Root port it is 100 ms, for a Hub port the delay is taken from Hub descriptor.
Device power-up delay in seconds	multiple options ranging from 0 to 40	Delay range is from 1 to 40 seconds, in one second increments

5.5 Chipset

Menu Path *Chipset*

This menu allows users to configure advanced Chipset settings such as **North Bridge** and **South Bridge** configuration parameters.

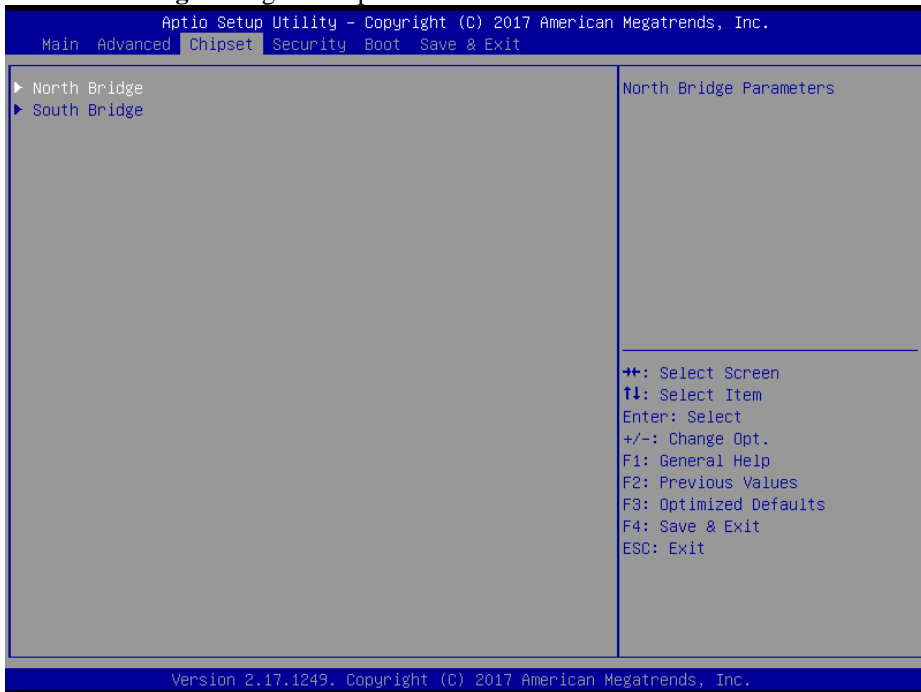

Chipset Screen

BIOS Setting	Options	Description/Purpose
North Bridge	Sub-menu	Sets Parameter for (North Bridge) configuration.
South Bridge	Sub-menu	Sets Parameter for (South Bridge) configuration.

5.5.1 North Bridge

Menu Path *Chipset > North Bridge*

The **North Bridge** allows users to configure LCD control settings and displays the DRAM information on the platform.

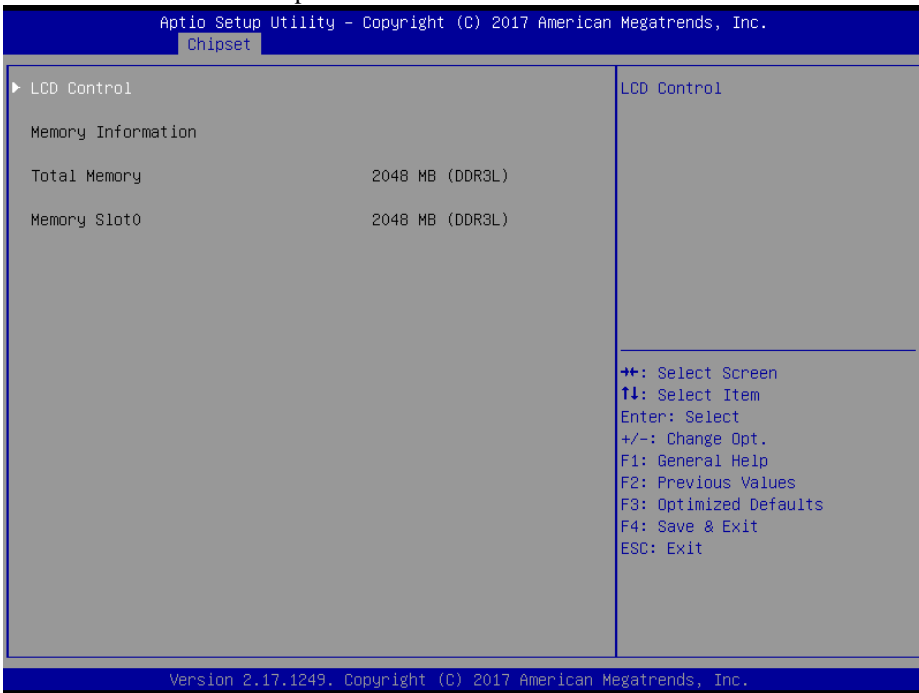

North Bridge Screen

BIOS Setting	Options	Description/Purpose
LCD Control	Sub-menu	Allows users to select the primary and secondary display device.
Memory Information	No changeable options	Displays the DRAM information on the platform.
Total Memory	No changeable options	Displays the DRAM size
Memory Slot0	No changeable options	Memory in the slot 0.

5.5.1.1 North Bridge – LCD Control

Menu Path *Chipset > North Bridge > LCD Control*

The **LCD Control** allows users to select the primary and secondary display device.

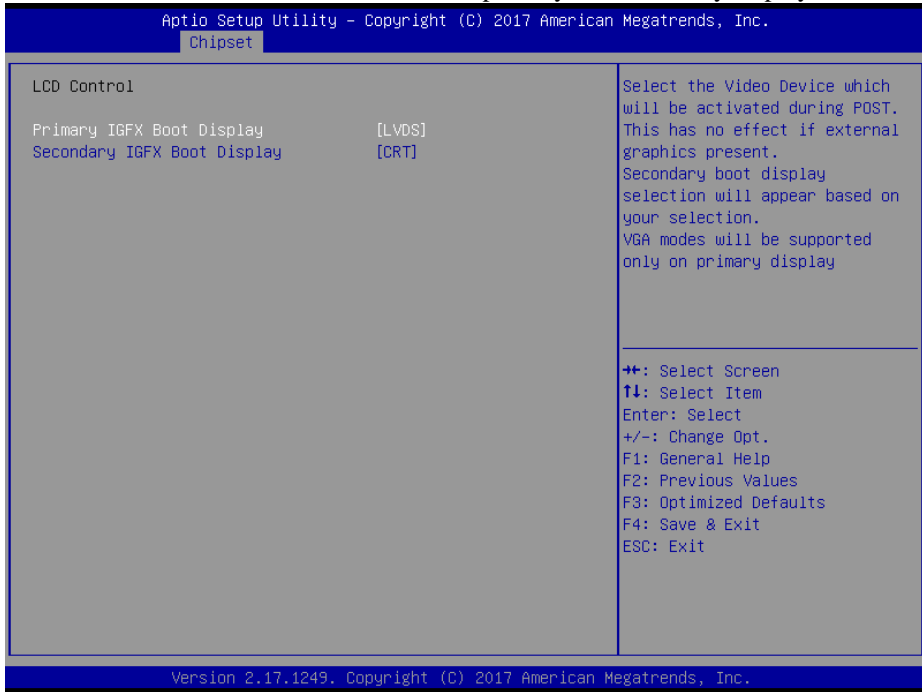

LCD Control Screen

BIOS Setting	Options	Description/Purpose
Primary IGFX Boot Display	- CRT - LVDS	Select Primary Display Device
Secondary IGFX Boot Display	- Disabled - CRT - LVDS	Select Secondary Display Device

5.5.2 South Bridge

Menu Path *Chipset > South Bridge*

The **South Bridge** allows users to configure computer's I/O functions.

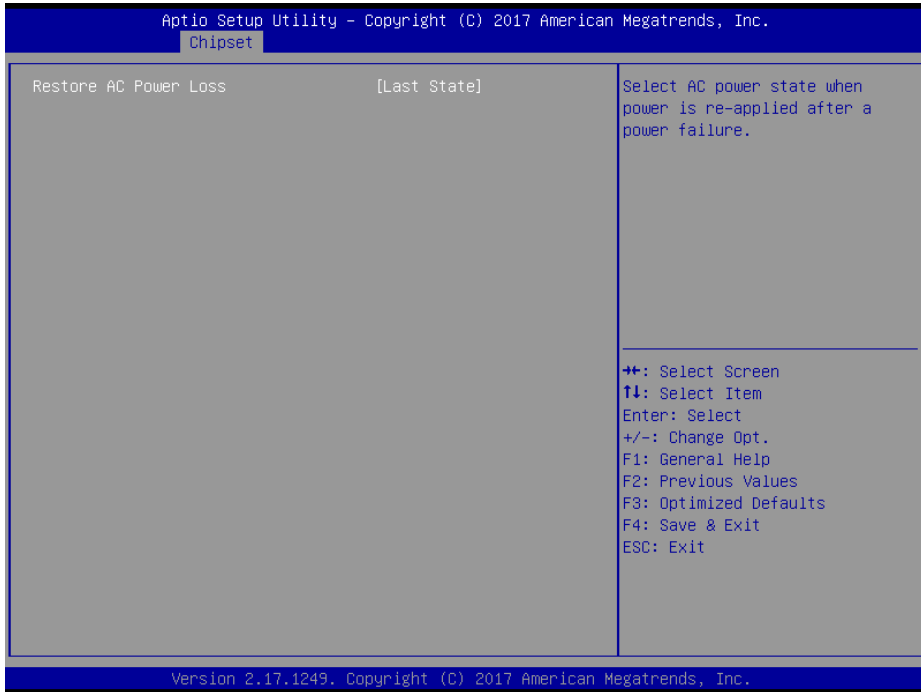

South Bridge Screen

BIOS Setting	Options	Description/Purpose
Restore AC Power Loss	<ul style="list-style-type: none"> - Power Off - Power On - Last State 	<p>Selects AC power state when the power is re-applied following a power failure.</p> <ul style="list-style-type: none"> • Power Off keeps the system powered off till the Power button is pressed. • Power On keeps the system powered on after the system restores AC power to the board. • Last State brings the system back to the last power state when the AC power is removed.

5.6 Security

Menu Path *Security*

From the **Security** menu, you are allowed to create, change or clear the administrator password. You will be asked to enter the configured administrator password before you can access the Setup Utility.

By setting an administrator password, you will prevent other users from changing your BIOS settings. You can configure an Administrator password and then configure a user password. An administrator has much more privileges over the settings in the Setup utility than a user. Heed that a user password does not provide access to most of the features in the Setup utility.

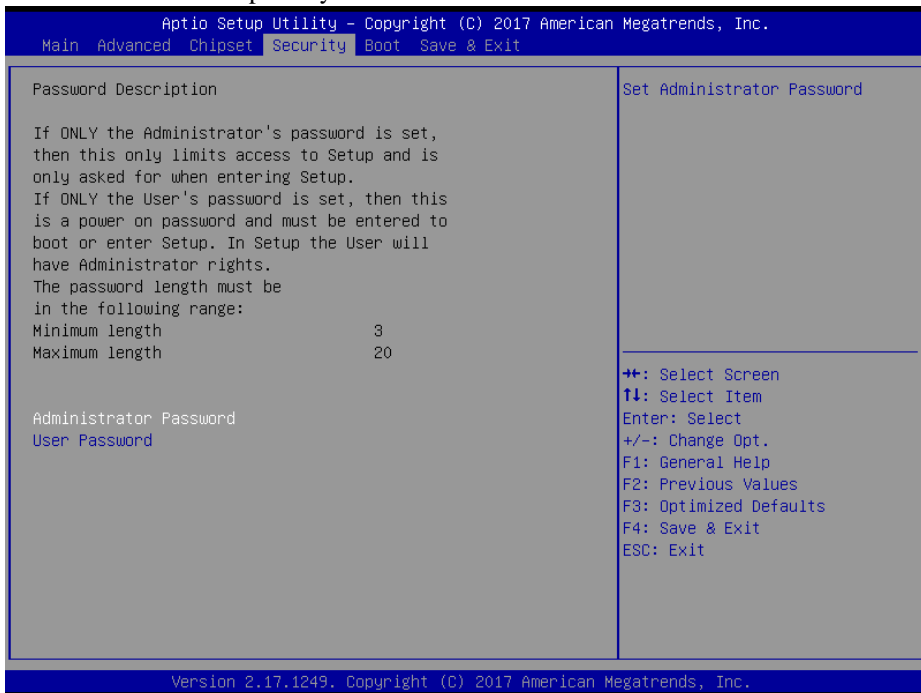

Security Screen

BIOS Setting	Options	Description/Purpose
Administrator Password	Password can be 3-20 alphanumeric characters.	Specifies the administrator password.
User Password	Password can be 3-20 alphanumeric characters.	Specifies the user password.

5.7 Boot

Menu Path *Boot*

This menu provides control items for system boot configuration such as setting setup prompt timeout, enabling/disabling quiet boot and fast boot, changing the boot order from the available bootable device(s) and Harddrive BBS option priorities.

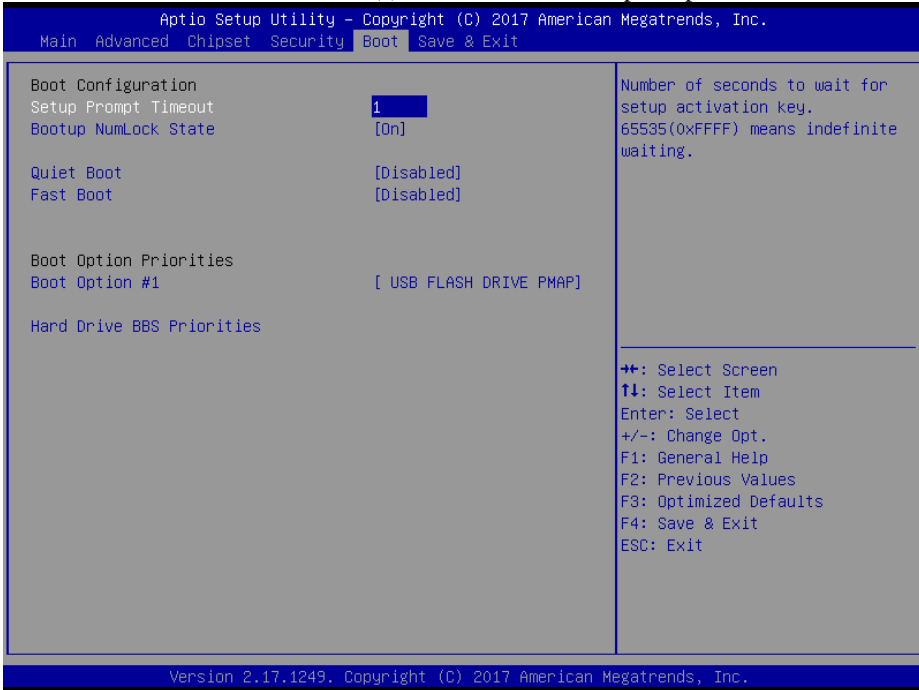

Boot Screen

BIOS Setting	Options	Description/Purpose
Setup Prompt Timeout	Numeric (from 1 to 65535)	Number of seconds to wait for setup activation key.
Bootup NumLock State	- On - Off	Specifies the power-on state of the NumLock Key.
Quiet Boot	- Disabled - Enabled	Enable or Disable Quiet Boot Options
Fast Boot	- Disabled - Enabled	Enable or Disable Fast Boot Options

BIOS Setting	Options	Description/Purpose
Boot Option #1~#n	- [Drive(s)] - Disabled	Set the system boot order.
Hard Drive BBS Priorities	Sub-Menu	Allow user to select boot order of available drive(s)

5.7.1 Boot – Hard Drive BBS Priorities

Menu Path *Boot > Hard Drive BBS Priorities*

Select **Hard Drive BBS Priorities** from the **Boot** menu to configure the boot order and priority of the available drives.

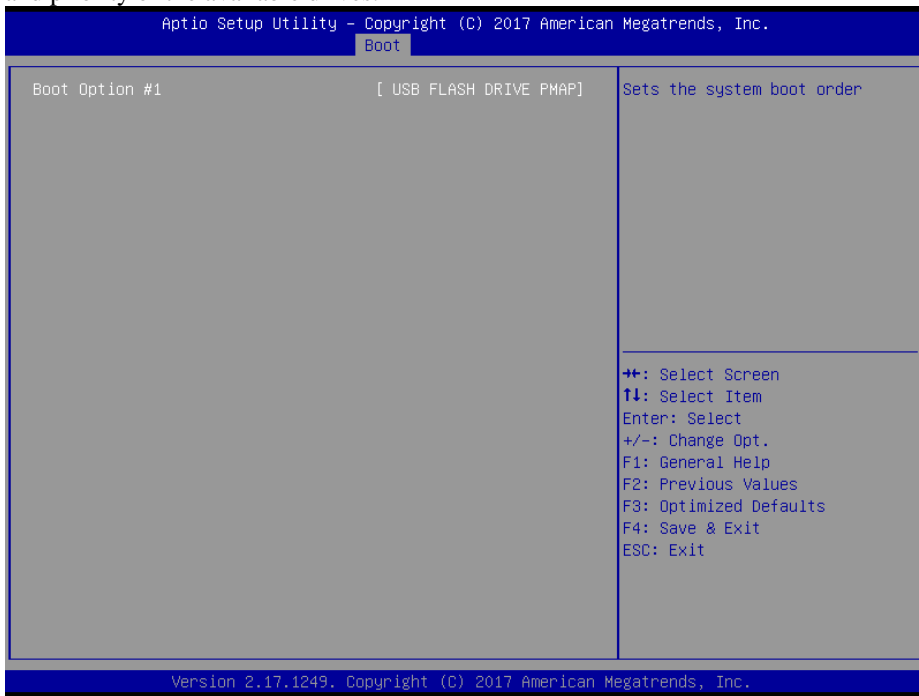

Hard Drive BBS Priorities Screen

BIOS Setting	Options	Description/Purpose
Boot Option #1~#n	- [Drive(s)] - Enabled	Set the system boot order for hard driver.

5.8 Save & Exit

Menu Path *Save & Exit*

The **Save & Exit** allows users to save or discard changed BIOS settings as well as load factory default settings.

Save Changed BIOS Settings

To save and validate the changed BIOS settings, select **Save Changes** from the **Save & Exit** menu to validate the changes and then exit the system. Select **Save Changes and Reset** to validate the changed BIOS settings and then restart the system

Discard Changed BIOS Settings

To cancel the BIOS settings you have previously configured, select **Discard Changes and Exit** from this menu, or simply press **Esc** to exit the BIOS setup. You can also select **Discard Changes and Reset** to discard any changes you have made and restore the factory BIOS defaults.

Load User Defaults

You may simply press **F3** at any time to load the **Optimized Values** which resets all BIOS settings to the factory defaults.

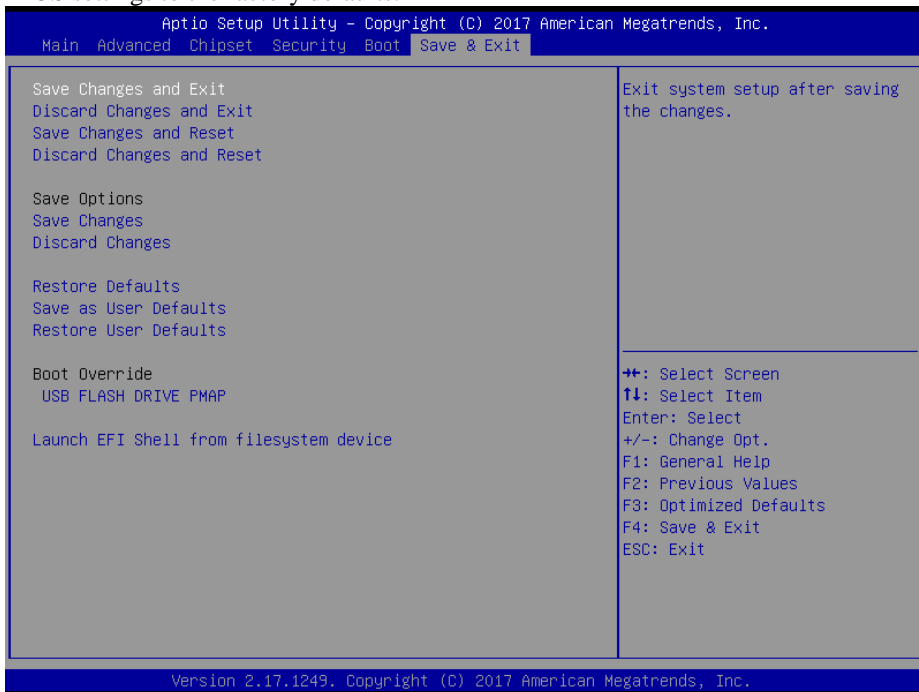

Save & Exit Screen

BIOS Setting	Options	Description/Purpose
Save Changes and Exit	No changeable options	Exits and saves the changes in NVRAM.
Discard Changes and Exit	No changeable options	Exits without saving any changes made in BIOS settings.
Save Changes and Reset	No changeable options	Saves the changes in NVRAM and resets.
Discard Changes and Reset	No changeable options	Resets without saving any changes made in BIOS settings.
Save Changes	No changeable options	Save Changes done so far to any of the setup options.
Discard Changes	No changeable options	Discard Changes done so far to any of the setup options.
Restore Defaults	No changeable options	Loads the optimized defaults for BIOS settings.
Save as User Defaults	No changeable options	Save the changes done so far as User Defaults.
Restore User Defaults	No changeable options	Restore the User Defaults to all the setup options.
Boot Override	- [Drive(s)]	Forces to boot from selected [drive(s)].

Appendix A System Diagrams

This appendix presents the exploded diagrams of the system as well as the part numbers of the PA-3222 system.

- Exploded Diagram for System Top Case
- Exploded Diagram for System
- Exploded Diagrams for System LCD Panel
- Exploded Diagram for HDD
- Exploded Diagram for MSR Module
- Exploded Diagram for Fingerprint Module
- Exploded Diagrams for Printer
- Exploded Diagram for VFD Module

Exploded Diagram For System Top Case

Open the System Top Module

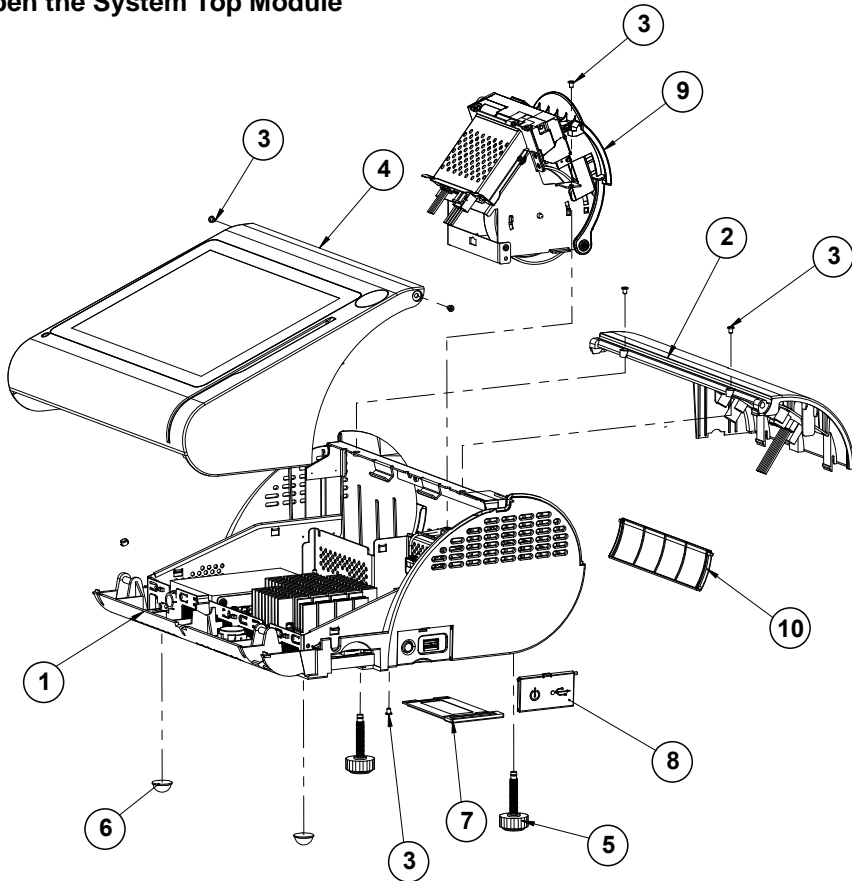

NO.	COMPONENT NAME	PART NO.	Q'TY	REMARK
1	PA-3222-Bot Unit	N/A	1	See Page A-3
2	PA-322_VFD_Unit	N/A	1	See Page A-16
3	M3_L4_I_B	22-272-30004318	7	
4	PA-3222_TOP Unit	N/A	1	See Page A-5~A-6
5	M6 Stand	22-289-60035007	2	
6	Rubber Foot(S1608)	30-004-01500000	2	
7	mini_pcie_door(Black)	30-007-28110165	1	
8	PA-3100 Side DOOR(Black)	30-007-28210165	1	
9	PA-3100_Printer_Unit	N/A	1	See Page A-11~A-14
10	PS-3100 I/O Cable Cover(Black)	30-002-28110165	1	
11	Lens(HHP-4F)	30-012-02100000	1	

System Exploded Diagram

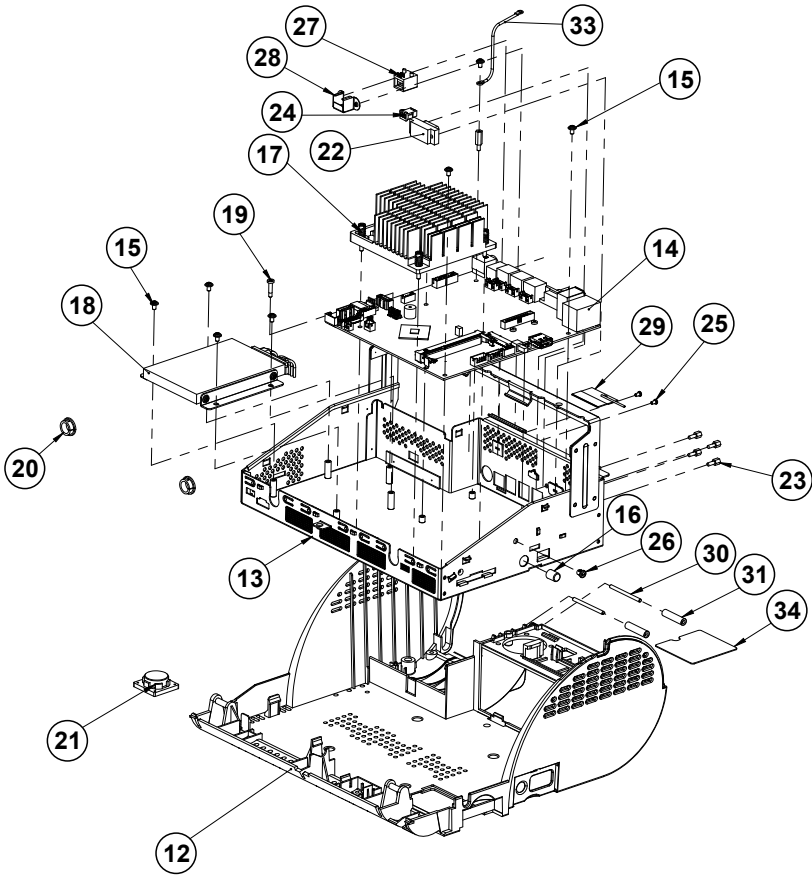

NO.	COMPONENT NAME	PART NO.	Q'TY	REMARK
12	PA-3520 bot(Black)	30-002-12210210	1	
13	PA-3222 Inside Box	80-040-03001400	1	
14	PA-6722 MB RC	PA-6722 MB RC	1	
15	M3 L5 W Ni	22-242-30005311	7	
16	Switch Cap(HS-10A)	30-001-28100099	1	
17	KF-7330 heat sink M	21-002-19090009	1	
18	HDD Unit	N/A	1	See Page A-8
19	M3 H9.86 L4.1 I NI	22-252-30017001	1	
20	Open Bushing(SA-1013A)	30-026-04300000	2	
21	PA-3211_Speaker	13-500-08280318	1	
22	PA-3222 com cable	27-024-40003031	1	
23	No.4 UNC H5 L7 BOSS	22-692-40048051	4	
24	PA-3222 2nd PWR Cable	27-012-21703071	1	
25	M2.5 L4 R Ni	22-232-25004011	2	
26	SB-0305	30-026-04100008	1	
27	PA-3222 Rj11_Cable	27-026-16505111	1	
28	RJ11 Holder	80-029-03002165	1	
29	wireless antenna	27-029-16506071	1	
30	roller_pin	22-092-29039001	2	
31	roller	30-041-04100165	2	
32	BOSS M3-H12 L6	22-258-30012051	1	
33	ground_cable	27-030-16504071	1	
34	fan_hole_pc_sheet	90-056-02100254	1	

Exploded Diagrams For System LCD Panel

With MSR and RFID Modules

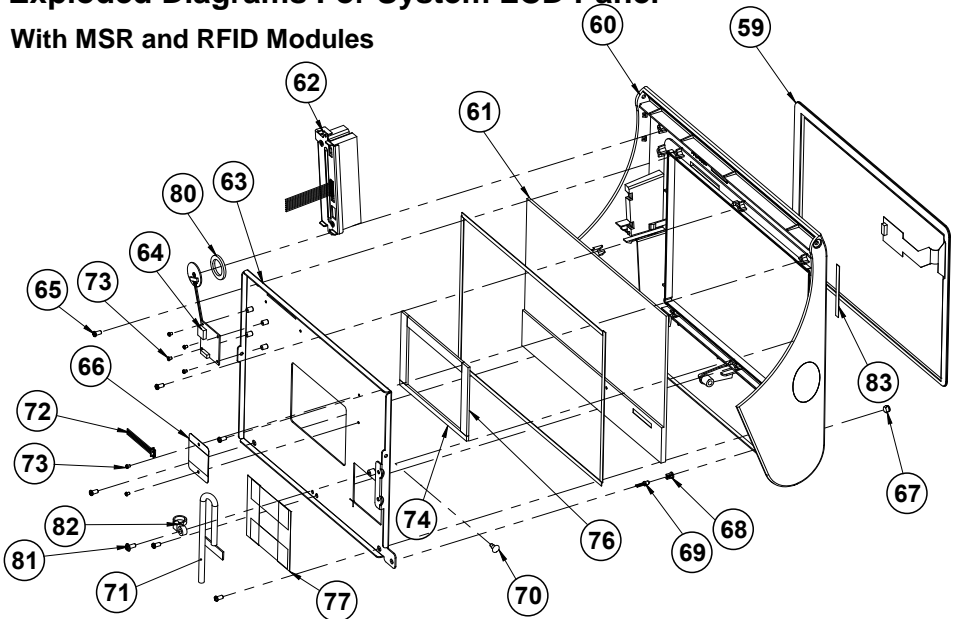

TYPE-N-N				
NO.	COMPONENT NAME	PART NO.	Q'TY	REMARK
59	10.1 Touch(USB type)	52-380-14143223	1	
60	PA-3211 TOP_CASE N-N	30-001-12410399	1	
61	10.2 Panel(TM101jdhp03)	52-351-12101028	1	
62	MSR Unit	N/A	1	See Page A-10
63	TM101jdhp03_holder	80-029-03002400	1	
64	RFID Device	52-551-00032000	1	
65	T3 L6 PAN NI	22-132-30060011	6	
66	Touch_PCB_Mylar	90-056-02100400	1	
67	Lens(HHP-4F)	30-012-02100000	1	
68	φ3 LED Housing	30-014-04100165	1	
69	led_3mm_green	27-018-40008071	1	
70	Canoe Clip(MB-1A)	30-076-04200000	1	
71	PA-3222 LCDS Cable	27-020-40005111	1	
72	PA-3122 Touch cable	27-016-40008111	1	
73	M2 L2.5 R Ni	22-222-20004011	6	
74	LCD_Tape_110x5x2.2	34-026-06101400	1	
75	LCD_Tape_90x10x2.2	34-026-06103400	1	
76	LCD_Tape_70x10x2.2	34-026-06102400	2	
77	61x22_Tape	94-034-04902400	4	
78	LCD PORON	90-013-24200304	2	
79	LCD PORON	90-013-24200304	2	
80	RFID-EVA	30-013-15100400	1	
81	M3 L7 W Ni	22-232-30007011	1	
82	cable_tipe	90-015-04100000	1	
83	double-sided_tape_52x4.5x0.25	34-026-04901400	1	

Exploded Diagrams For System LCD Panel With MSR and Fingerprint Modules

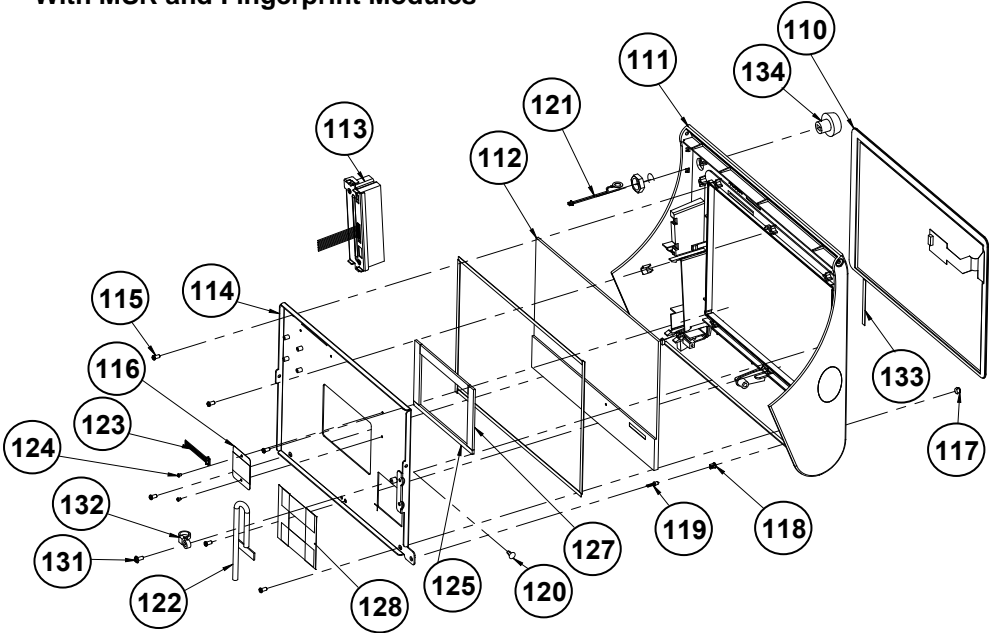

TYPE I-N				
NO.	COMPONENT NAME	PART NO.	Q'TY	REMARK
110	10.1 Touch(USB type)	52-380-14143223	1	
111	PA-3211_TOP_CASE_I-N	30-001-12110399	1	
112	10.2 Panel(TM101jdhp03)	52-351-12101028	1	
113	MSR Unit	N/A	1	See Page A-10
114	TM101jdhp03_holder	80-029-03002400	1	
115	T3_L6_PAN_Ni	22-132-30060011	6	
116	Touch_PCB_Mylar	90-056-02100400	1	
117	Lens(HHP-4F)	30-012-02100000	1	
118	φ3 LED Housing	30-014-04100165	1	
119	led_3mm_green	27-018-40008071	1	
120	Canoe Clip(MB-1A)	30-076-04200000	1	
121	PA-3222_I-button_cable	xxx-xxxxxxxxxxx	1	
122	PA-3222_LCDS_Cable	27-020-40005111	1	
123	PA-3122_Touch_cable	27-016-40008111	1	
124	M2_L2.5_R_Ni	22-222-20004011	2	
125	LCD_Tape_110x5x2.2	34-026-06101400	1	
126	LCD_Tape_90x10x2.2	34-026-06103400	1	
127	LCD_Tape_70x10x2.2	34-026-06102400	2	
128	61x22_Tape	94-034-04902400	4	
129	LCD PORON	90-013-24200304	2	
130	LCD PORON	90-013-24200304	2	
131	M3_L7_W_Ni	22-232-30007011	1	
132	cable_tipe	90-015-04100000	1	
133	double-sided_tape_52x4.5x0.25	34-026-04901400	1	
134	i-button_IBT200MX	52-551-00100002	1	

**Exploded Diagrams For System LCD Panel
With MSR and i-Button Modules**

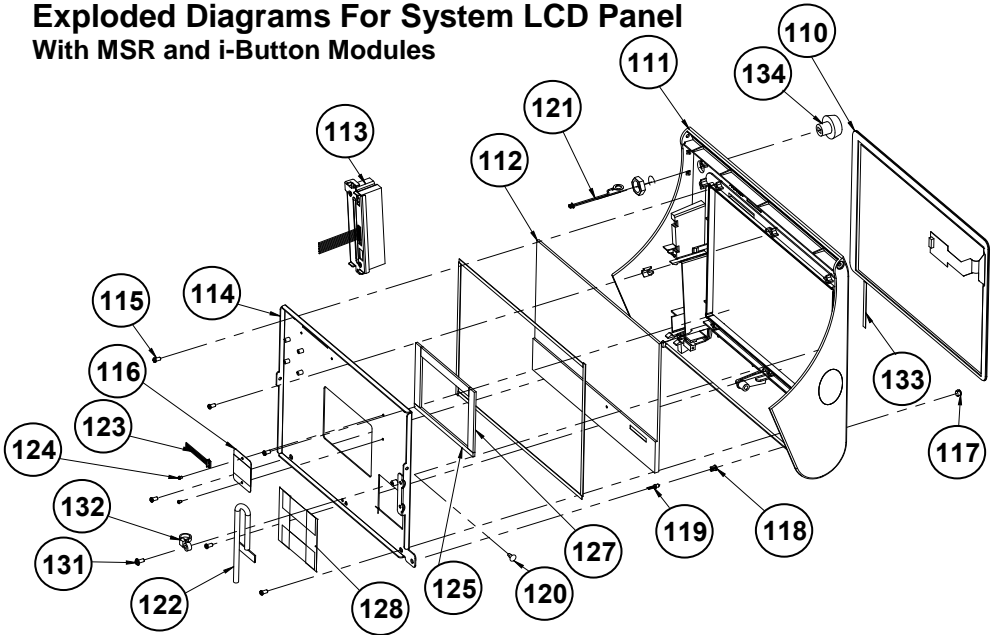

TYPE I-N				
NO.	COMPONENT NAME	PART NO.	Q'TY	REMARK
110	10.1 Touch(USB type)	52-380-14143223	1	
111	PA-3211_TOP_CASE_I-N	30-001-12110399	1	
112	10.2 Panel(TM101jdhp03)	52-351-12101028	1	
113	MSR Unit	N/A	1	See Page A-10
114	TM101jdhp03_holder	80-029-03002400	1	
115	T3_L6_PAN_Ni	22-132-30060011	6	
116	Touch_PCB_Mylar	90-056-02100400	1	
117	Lens(HHP-4F)	30-012-02100000	1	
118	φ3 LED Housing	30-014-04100165	1	
119	led_3mm_green	27-018-40008071	1	
120	Canoe Clip(MB-1A)	30-076-04200000	1	
121	PA-3222_I-button_cable	xxx-xxxxxxxxxxx	1	
122	PA-3222_LCDS_Cable	27-020-40005111	1	
123	PA-3122_Touch_cable	27-016-40008111	1	
124	M2_L2.5_R_Ni	22-222-20004011	2	
125	LCD_Tape_110x5x2.2	34-026-06101400	1	
126	LCD_Tape_90x10x2.2	34-026-06103400	1	
127	LCD_Tape_70x10x2.2	34-026-06102400	2	
128	61x22_Tape	94-034-04902400	4	
129	LCD PORON	90-013-24200304	2	
130	LCD PORON	90-013-24200304	2	
131	M3_L7_W_Ni	22-232-30007011	1	
132	cable_tape	90-015-04100000	1	
133	double-sided_tape_52x4.5x0.25	34-026-04901400	1	
134	i-button_IBT200MX	52-551-00100002	1	

Exploded Diagram For HDD

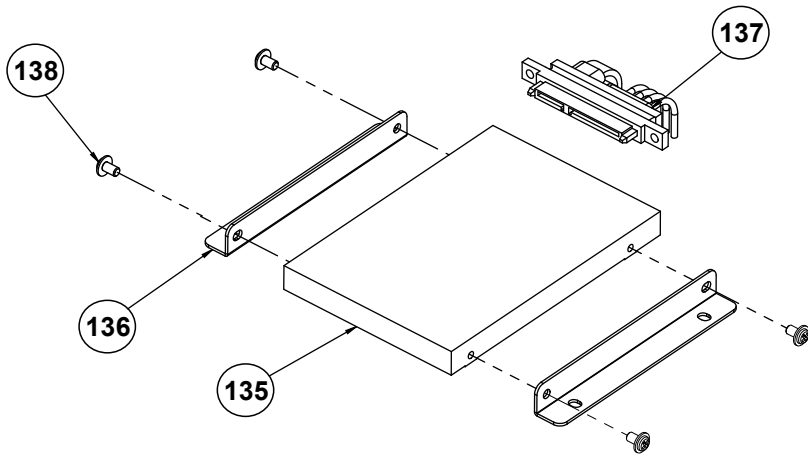

NO.	COMPONENT NAME	PART NO.	Q'TY	REMARK
135	2inch_SATA_HDD	See Order	1	
136	PA-3222 HDD Holder	80-029-03001400	2	
137	Sata Cable	27-012-33903081	1	
138	M3_L5_W_Ni	22-242-30005311	4	

Exploded Diagram For MSR Module

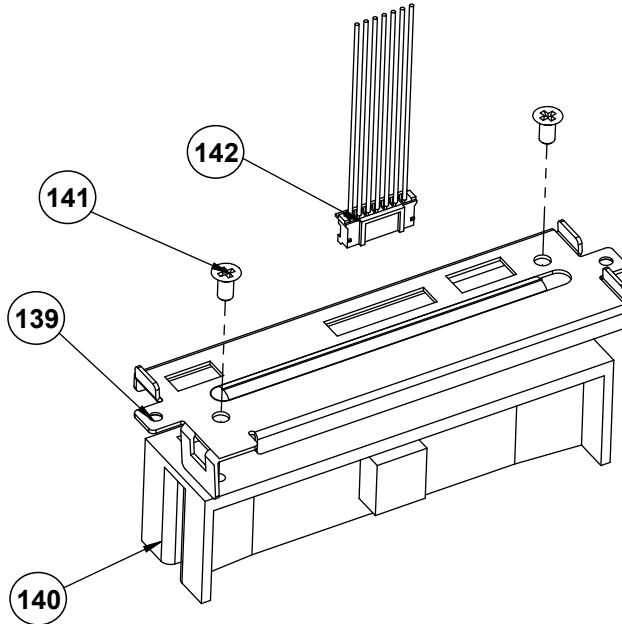

NO.	COMPONENT NAME	PART NO.	Q'TY	REMARK
139	ps3100_msr_holder.sldprt	20-029-03005165	1	
140	MSR	See Order	1	
141	M3_L6_F_B	22-215-30060011	2	
142	PA-3222_msr_cable		1	

Exploded Diagram For Fingerprint Module

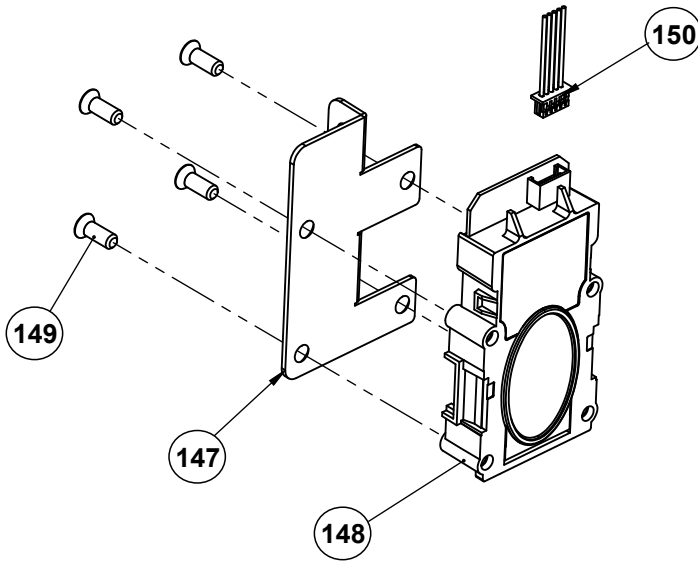

NO.	COMPONENT NAME	PART NO.	Q'TY	REMARK
147	PA-3211_finger_printer_holder	20-029-03001399	1	
148	finger_printer	52-551-00501205	1	
149	T3 L8 flat Ni	22-112-30008311	4	
150	Finger_printer_cable	27-004-40010111	1	

Exploded Diagram For 3-Inch Printer (1)

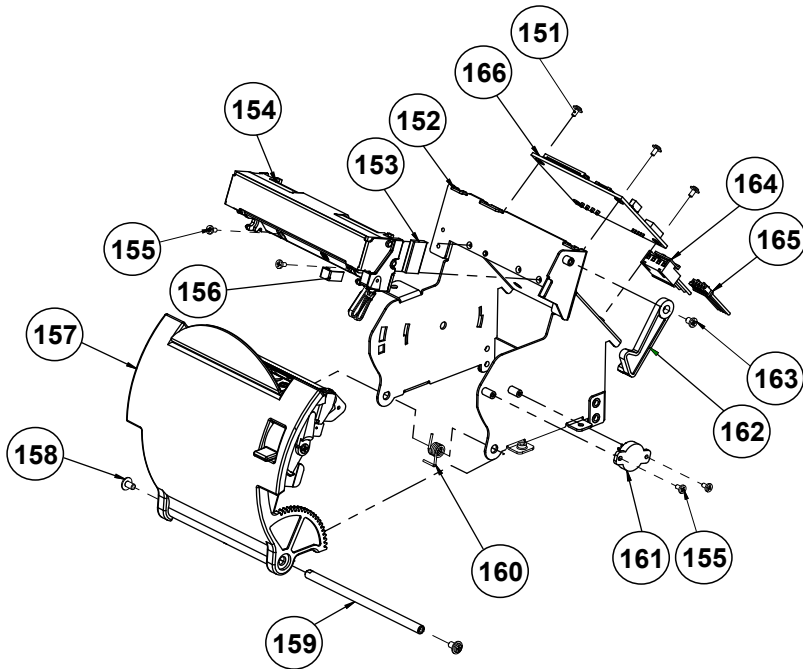

3 Inch Printer				
NO.	COMPONENT NAME	PART NO.	Q'TY	REMARK
151	M2_L4_W_Ni	22-232-20004311	3	
152	ps3100_printer_box3	20-040-03001210	1	
153	EMI_GASKET_17X10x3	90-050-31300165	1	
154	SII 3" Thermal Printer(Base Slide)	52-701-05017003	1	
155	M2_L4_I_Ni	22-272-20004011	4	
156	EMI_GASKET_20X5x0.5	90-050-31200165	1	
157	ps3100_paper_cover_Unit	N/A	1	See Next Page
158	M3_L5_W_Ni	22-242-30005311	2	
159	paper_cover_pin	20-004-10011165	1	
160	ps3100-spring-1	23-002-00000701	1	
161	pg-13-270p	30-022-09110000	1	
162	printer_add_arm	30-002-09110165	1	
163	M3_L4_I_B	22-272-30004318	1	
164	printer_power_cable	27-012-16502071	1	
165	PA-3222_printer_cable(USB)	27-006-40307111	1	
166	MB-1011RB-11N	MB-1011RB-11N	1	

Exploded Diagram For 3-Inch Printer (2)

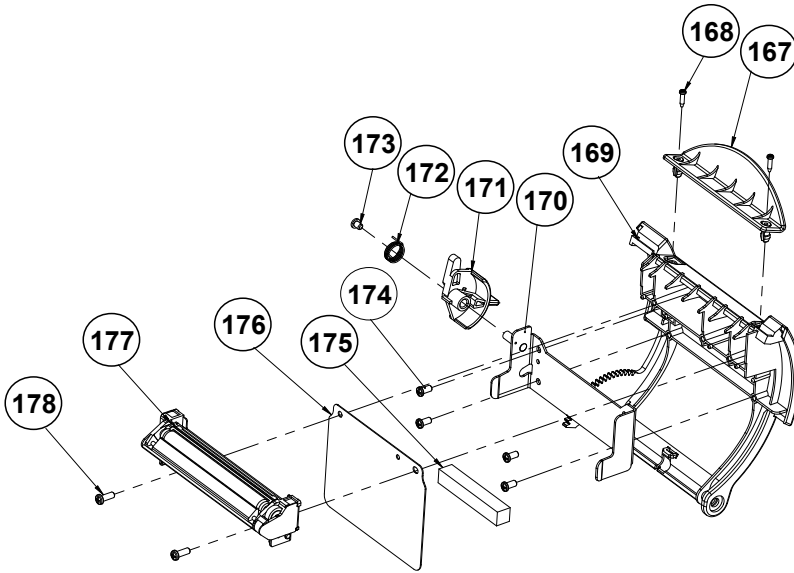

3 Inch Printer				
NO.	COMPONENT NAME	PART NO.	Q'TY	REMARK
167	paper_holder2.sldprt	30-012-02110165	1	
168	T2_L8_R_B	22-125-20008011	2	
169	ps3100_paper_cover_v2	30-002-02530165	1	
170	include_holder	20-029-03006165	1	
171	ps3100_printer_cover_ejector	30-002-09210165	1	
172	ps3100-spring-for_ejector	23-002-00001021	1	
173	M3_L4_I_B	22-272-30004318	1	
174	T3_L6_PAN_NI	22-132-30060011	4	
175	3100_printer_eva	90-013-15200165	1	
176	3inch_add_mylar	90-056-02600165	1	
177	3" Thermal Printer(Cut Side)	N/A	1	
178	T3_L8_R_B	22-122-30080011	2	

Exploded Diagram For 2-Inch Printer (1)

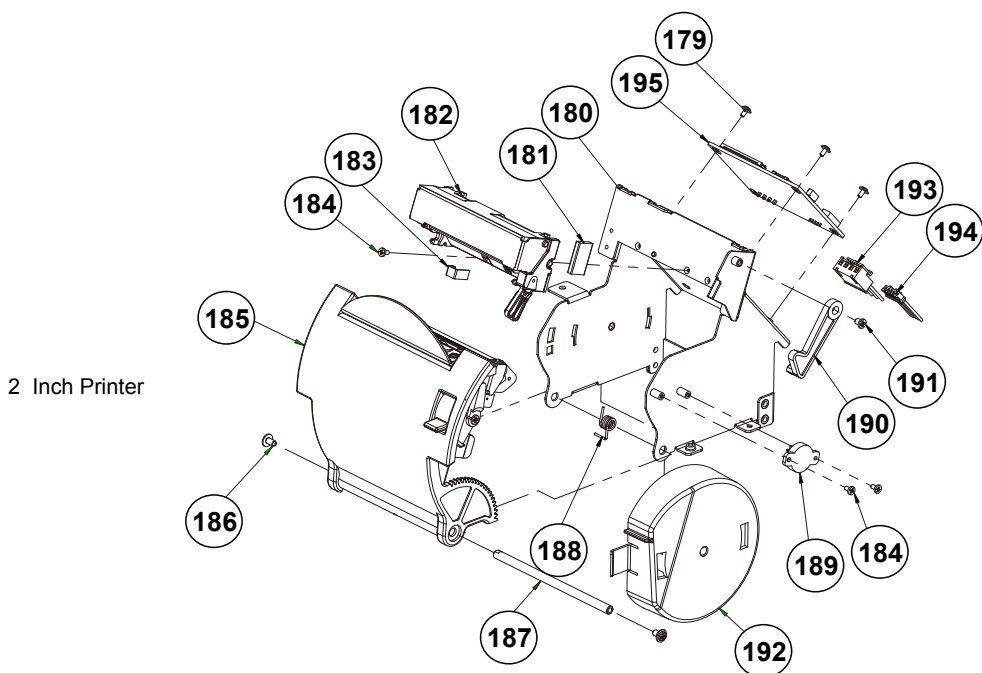

2 Inch Printer				
NO.	COMPONENT NAME	PART NO.	Q'TY	REMARK
179	M2_L4_W_Ni	22-232-20004311	3	
180	ps3100_printer_box3	20-040-03001210	1	
181	EMI GASKET 17X10x3	90-050-31300165	1	
182	5/16 2" Thermal Printer(Base Side)	52-701-01020003	1	
183	EMI GASKET 20X5x0.5	90-050-31200165	1	
184	M2_L4_I_Ni	22-272-20004011	3	
185	ps3100_paper_cover_Unit	N/A	1	See Next Page
186	M3_L5_W_Ni	22-242-30005311	2	
187	paper_cover_pin	20-004-10011165	1	
188	ps3100-spring-1	23-002-00000701	1	
189	pg-13-270p	30-022-09110000	1	
190	printer_add_arm	30-002-09110165	1	
191	M3_L4_I_B	22-272-30004318	1	
192	add_paper_wall	30-002-28310165	1	
193	printer_power_cable	27-012-16502071	1	
194	PA-3222_printer_cable(USB)	27-006-40307111	1	
195	MB-1011RB-11N	MB-1011RB-11N	1	

Exploded Diagram For 2-Inch Printer (2)

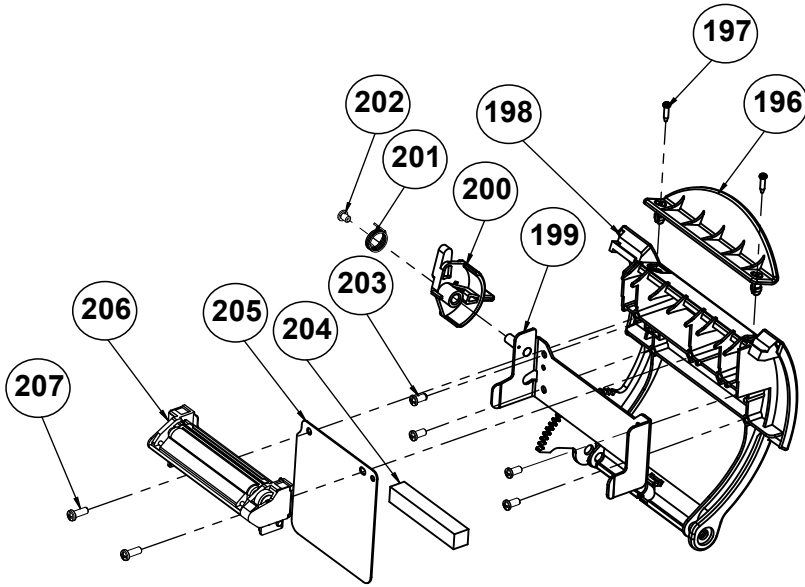

2 Inch Printer				
NO.	COMPONENT NAME	PART NO.	Q'TY	REMARK
196	paper_holder2.sldprt	30-012-02110165	1	
197	T2 L8 R B	22-125-20008011	2	
198	ps3100_paper_cover_v2	30-002-02530165	1	
199	include_holder	20-029-03006165	1	
200	ps3100_printer_cover_ejector	30-002-09210165	1	
201	ps3100-spring-for_ejector	23-002-00001021	1	
202	M3 L4 I B	22-272-30004318	1	
203	T3 L6 PAN NI	22-132-30060011	4	
204	3100_printer_eva	90-013-15200165	1	
205	2inch_add_mylar2	90-056-02300165	1	
206	2" Thermal Printer(Cut Side)	N/A	1	
207	T3 L8 R B	22-122-30080011	2	

With Paper Holder

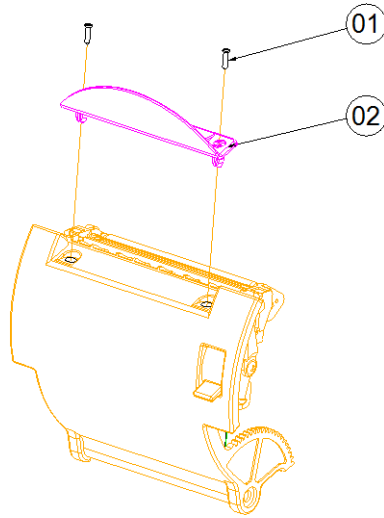

Without Paper Holder

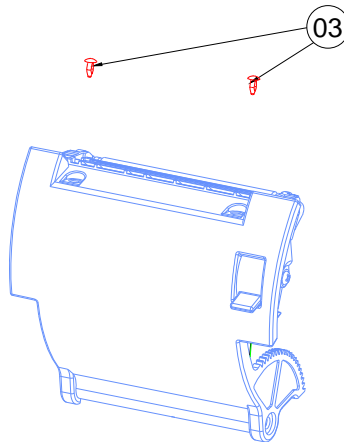

No.	Name	P/N No.	Qty
1	T2_L8_Black	22-125-20008011	2
2	PAPER HOLDER(Transparent)	30-012-02210165	1
	PAPER HOLDER(Black)	30-012-02110165	
3	Ø4 Plastic rivet	90-076-04110000	2

Exploded Diagram For VFD Module

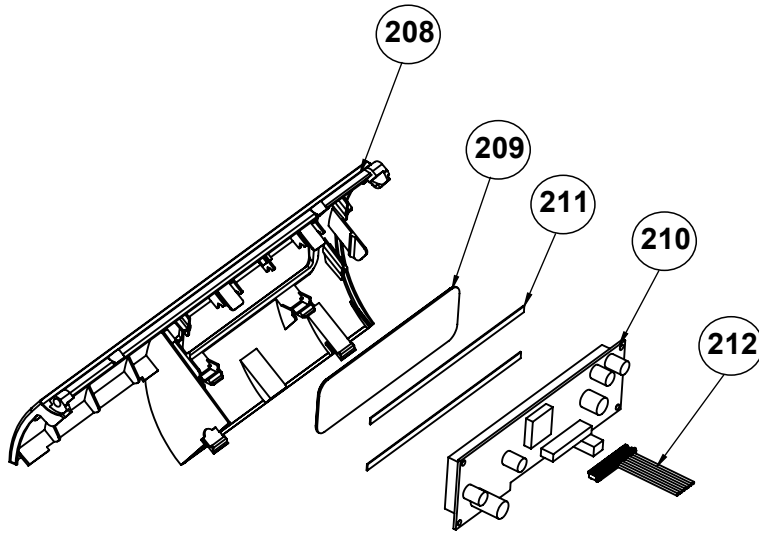

NO.	COMPONENT NAME	PART NO.	Q'TY	REMARK
208	ps3100_vfd_cover	30-002-28114165	1	
209	ps3100_vfd_window	30-002-02230165	1	
210	VFD_Model	MB-4103RA-11N	1	
211	PORON_135x4x0.5	90-013-24100165	2	
212	PA-3222_VFD_CABLE	27-053-23805111	1	

Appendix B Technical Summary

This appendix will give you a brief introduction of the allocation maps for the system resources.

The following topics are included:

- Interrupt Map
- DMA Channels Map
- I/O Map
- Memory Map
- Configuring WatchDog Timer
- Flash BIOS Update

Interrupt Map

IRQ	ASSIGNMENT
IRQ 0	System timer
IRQ 1	Standard PS/2 Keyboard
IRQ 3	Communications Port (COM2)
IRQ 4	Communications Port (COM1)
IRQ 7	Communications Port (COM3)
IRQ 8	High precision event timer
IRQ 10	Communications Port (COM4)
IRQ 10	Intel(R) Atom(TM)/Celeron(R)/Pentium(R) Processor Platform Control Unit - SMBus Port - 0F12
IRQ 12	PS/2 Compatible Mouse
IRQ 16	Intel(R) Atom(TM)/Celeron(R)/Pentium(R) Processor PCI Express - Root Port 1 - 0F48
IRQ 17	Intel(R) Atom(TM)/Celeron(R)/Pentium(R) Processor PCI Express - Root Port 2 - 0F4A
IRQ 18	Intel(R) Atom(TM)/Celeron(R)/Pentium(R) Processor PCI Express - Root Port 3 - 0F4C
IRQ 19	Intel(R) Atom(TM)/Celeron(R)/Pentium(R) Processor PCI Express - Root Port 4 - 0F4E
IRQ 19	Intel(R) Atom(TM)/Celeron(R)/Pentium(R) Processor AHCI - 0F23
IRQ 22	High Definition Audio Controller
IRQ 81	Microsoft ACPI-Compliant System
IRQ 82	Microsoft ACPI-Compliant System
IRQ 83	Microsoft ACPI-Compliant System
IRQ 84	Microsoft ACPI-Compliant System
IRQ 85	Microsoft ACPI-Compliant System
IRQ 86	Microsoft ACPI-Compliant System
IRQ 87	Microsoft ACPI-Compliant System
IRQ 88	Microsoft ACPI-Compliant System
IRQ 89	Microsoft ACPI-Compliant System
IRQ 90	Microsoft ACPI-Compliant System
IRQ 91	Microsoft ACPI-Compliant System
IRQ 92	Microsoft ACPI-Compliant System
IRQ 93	Microsoft ACPI-Compliant System
IRQ 94	Microsoft ACPI-Compliant System
IRQ 95	Microsoft ACPI-Compliant System
IRQ 96	Microsoft ACPI-Compliant System
IRQ 97	Microsoft ACPI-Compliant System
IRQ 98	Microsoft ACPI-Compliant System
IRQ 99	Microsoft ACPI-Compliant System

IRQ	ASSIGNMENT
IRQ 100	Microsoft ACPI-Compliant System
IRQ 101	Microsoft ACPI-Compliant System
IRQ 102	Microsoft ACPI-Compliant System
IRQ 103	Microsoft ACPI-Compliant System
IRQ 104	Microsoft ACPI-Compliant System
IRQ 105	Microsoft ACPI-Compliant System
IRQ 106	Microsoft ACPI-Compliant System
IRQ 107	Microsoft ACPI-Compliant System
IRQ 108	Microsoft ACPI-Compliant System
IRQ 109	Microsoft ACPI-Compliant System
IRQ 110	Microsoft ACPI-Compliant System
IRQ 111	Microsoft ACPI-Compliant System
IRQ 112	Microsoft ACPI-Compliant System
IRQ 113	Microsoft ACPI-Compliant System
IRQ 114	Microsoft ACPI-Compliant System
IRQ 115	Microsoft ACPI-Compliant System
IRQ 116	Microsoft ACPI-Compliant System
IRQ 117	Microsoft ACPI-Compliant System
IRQ 118	Microsoft ACPI-Compliant System
IRQ 119	Microsoft ACPI-Compliant System
IRQ 120	Microsoft ACPI-Compliant System
IRQ 121	Microsoft ACPI-Compliant System
IRQ 122	Microsoft ACPI-Compliant System
IRQ 123	Microsoft ACPI-Compliant System
IRQ 124	Microsoft ACPI-Compliant System
IRQ 125	Microsoft ACPI-Compliant System
IRQ 126	Microsoft ACPI-Compliant System
IRQ 127	Microsoft ACPI-Compliant System
IRQ 128	Microsoft ACPI-Compliant System
IRQ 129	Microsoft ACPI-Compliant System
IRQ 130	Microsoft ACPI-Compliant System
IRQ 131	Microsoft ACPI-Compliant System
IRQ 132	Microsoft ACPI-Compliant System
IRQ 133	Microsoft ACPI-Compliant System
IRQ 134	Microsoft ACPI-Compliant System
IRQ 135	Microsoft ACPI-Compliant System
IRQ 136	Microsoft ACPI-Compliant System
IRQ 137	Microsoft ACPI-Compliant System
IRQ 138	Microsoft ACPI-Compliant System
IRQ 139	Microsoft ACPI-Compliant System
IRQ 140	Microsoft ACPI-Compliant System

IRQ	ASSIGNMENT
IRQ 141	Microsoft ACPI-Compliant System
IRQ 142	Microsoft ACPI-Compliant System
IRQ 143	Microsoft ACPI-Compliant System
IRQ 144	Microsoft ACPI-Compliant System
IRQ 145	Microsoft ACPI-Compliant System
IRQ 146	Microsoft ACPI-Compliant System
IRQ 147	Microsoft ACPI-Compliant System
IRQ 148	Microsoft ACPI-Compliant System
IRQ 149	Microsoft ACPI-Compliant System
IRQ 150	Microsoft ACPI-Compliant System
IRQ 151	Microsoft ACPI-Compliant System
IRQ 152	Microsoft ACPI-Compliant System
IRQ 153	Microsoft ACPI-Compliant System
IRQ 154	Microsoft ACPI-Compliant System
IRQ 155	Microsoft ACPI-Compliant System
IRQ 156	Microsoft ACPI-Compliant System
IRQ 157	Microsoft ACPI-Compliant System
IRQ 158	Microsoft ACPI-Compliant System
IRQ 159	Microsoft ACPI-Compliant System
IRQ 160	Microsoft ACPI-Compliant System
IRQ 161	Microsoft ACPI-Compliant System
IRQ 162	Microsoft ACPI-Compliant System
IRQ 163	Microsoft ACPI-Compliant System
IRQ 164	Microsoft ACPI-Compliant System
IRQ 165	Microsoft ACPI-Compliant System
IRQ 166	Microsoft ACPI-Compliant System
IRQ 167	Microsoft ACPI-Compliant System
IRQ 168	Microsoft ACPI-Compliant System
IRQ 169	Microsoft ACPI-Compliant System
IRQ 170	Microsoft ACPI-Compliant System
IRQ 171	Microsoft ACPI-Compliant System
IRQ 172	Microsoft ACPI-Compliant System
IRQ 173	Microsoft ACPI-Compliant System
IRQ 174	Microsoft ACPI-Compliant System
IRQ 175	Microsoft ACPI-Compliant System
IRQ 176	Microsoft ACPI-Compliant System
IRQ 177	Microsoft ACPI-Compliant System
IRQ 178	Microsoft ACPI-Compliant System
IRQ 179	Microsoft ACPI-Compliant System
IRQ 180	Microsoft ACPI-Compliant System
IRQ 181	Microsoft ACPI-Compliant System

IRQ	ASSIGNMENT
IRQ 182	Microsoft ACPI-Compliant System
IRQ 183	Microsoft ACPI-Compliant System
IRQ 184	Microsoft ACPI-Compliant System
IRQ 185	Microsoft ACPI-Compliant System
IRQ 186	Microsoft ACPI-Compliant System
IRQ 187	Microsoft ACPI-Compliant System
IRQ 188	Microsoft ACPI-Compliant System
IRQ 189	Microsoft ACPI-Compliant System
IRQ 190	Microsoft ACPI-Compliant System
IRQ 4294967292	Realtek PCIe GBE Family Controller
IRQ 4294967293	Intel(R) USB 3.0 eXtensible Host Controller
IRQ 4294967294	Intel(R) Atom(TM) Processor E3800 Series/Intel(R) Celeron(R) Processor N2920/J1900

Note: These resource information were gathered using Windows 7 (the IRQ could be assigned differently depending on OS)

DMA MAP

DMA	ASSIGNMENT
Channel 3	Printer Port (LPT1)

I/O Map

I/O	ASSIGNMENT
0x00000000-0x0000006F	PCI bus
0x00000020-0x00000021	Programmable interrupt controller
0x00000024-0x00000025	Programmable interrupt controller
0x00000028-0x00000029	Programmable interrupt controller
0x0000002C-0x0000002D	Programmable interrupt controller
0x0000002E-0x0000002F	Motherboard resources
0x00000030-0x00000031	Programmable interrupt controller
0x00000034-0x00000035	Programmable interrupt controller
0x00000038-0x00000039	Programmable interrupt controller
0x0000003C-0x0000003D	Programmable interrupt controller
0x00000040-0x00000043	System timer
0x0000004E-0x0000004F	Motherboard resources
0x00000050-0x00000053	System timer
0x00000060-0x00000060	Standard PS/2 Keyboard
0x00000061-0x00000061	Motherboard resources
0x00000063-0x00000063	Motherboard resources
0x00000064-0x00000064	Standard PS/2 Keyboard
0x00000065-0x00000065	Motherboard resources
0x00000067-0x00000067	Motherboard resources
0x00000070-0x00000077	System CMOS/real time clock
0x00000070-0x00000077	Motherboard resources
0x00000078-0x000000CF	PCI bus
0x00000080-0x0000008F	Motherboard resources
0x00000092-0x00000092	Motherboard resources
0x000000A0-0x000000A1	Programmable interrupt controller
0x000000A4-0x000000A5	Programmable interrupt controller
0x000000A8-0x000000A9	Programmable interrupt controller
0x000000AC-0x000000AD	Programmable interrupt controller
0x000000B0-0x000000B1	Programmable interrupt controller
0x000000B2-0x000000B3	Motherboard resources
0x000000B4-0x000000B5	Programmable interrupt controller
0x000000B8-0x000000B9	Programmable interrupt controller
0x000000BC-0x000000BD	Programmable interrupt controller
0x000002E8-0x000002EF	Communications Port (COM4)
0x000002F8-0x000002FF	Communications Port (COM2)
0x00000378-0x0000037F	Printer Port (LPT1)
0x000003B0-0x000003BB	Intel(R) Atom(TM) Processor E3800 Series/Intel(R) Celeron(R) Processor N2920/J1900

I/O	ASSIGNMENT
0x000003C0-0x000003DF	Intel(R) Atom(TM) Processor E3800 Series/Intel(R) Celeron(R) Processor N2920/J1900
0x000003E8-0x000003EF	Communications Port (COM3)
0x000003F8-0x000003FF	Communications Port (COM1)
0x00000400-0x0000047F	Motherboard resources
0x000004D0-0x000004D1	Programmable interrupt controller
0x00000500-0x000005FE	Motherboard resources
0x00000600-0x0000061F	Motherboard resources
0x00000680-0x0000069F	Motherboard resources
0x00000A00-0x00000A0F	Motherboard resources
0x00000A10-0x00000A1F	Motherboard resources
0x00000A20-0x00000A2F	Motherboard resources
0x00000D00-0x0000FFFF	PCI bus
0x0000E000-0x0000EFFF	Intel(R) Atom(TM)/Celeron(R)/Pentium(R) Processor PCI Express - Root Port 4 - 0F4E
0x0000E000-0x0000EFFF	Realtek PCIe GBE Family Controller
0x0000F000-0x0000F01F	Intel(R) Atom(TM)/Celeron(R)/Pentium(R) Processor Platform Control Unit - SMBus Port - 0F12
0x0000F020-0x0000F03F	Intel(R) Atom(TM)/Celeron(R)/Pentium(R) Processor AHCI - 0F23
0x0000F040-0x0000F043	Intel(R) Atom(TM)/Celeron(R)/Pentium(R) Processor AHCI - 0F23
0x0000F050-0x0000F057	Intel(R) Atom(TM)/Celeron(R)/Pentium(R) Processor AHCI - 0F23
0x0000F060-0x0000F063	Intel(R) Atom(TM)/Celeron(R)/Pentium(R) Processor AHCI - 0F23
0x0000F070-0x0000F077	Intel(R) Atom(TM)/Celeron(R)/Pentium(R) Processor AHCI - 0F23
0x0000F080-0x0000F087	Intel(R) Atom(TM) Processor E3800 Series/Intel(R) Celeron(R) Processor N2920/J1900
0x00000000-0x0000006F	PCI bus

Memory Map

MEMORY MAP	ASSIGNMENT
0xD0600000-0xD06FFFFF	Intel(R) Atom(TM)/Celeron(R)/Pentium(R) Processor PCI Express - Root Port 4 - 0F4E
0xD0600000-0xD06FFFFF	Realtek PCIe GBE Family Controller
0xFF000000-0xFFFFFFFF	Intel(R) 82802 Firmware Hub Device
0xE00000D0-0xE00000DB	Intel(R) Atom(TM)/Celeron(R)/Pentium(R) Processor MBI Device - 33BD
0xD0716000-0xD07167FF	Intel(R) Atom(TM)/Celeron(R)/Pentium(R) Processor AHCI - 0F23
0xD0000000-0xD03FFFFF	Intel(R) Atom(TM) Processor E3800 Series/Intel(R) Celeron(R) Processor N2920/J1900
0xC0000000-0xCFFFFFFF	Intel(R) Atom(TM) Processor E3800 Series/Intel(R) Celeron(R) Processor N2920/J1900
0xC0000000-0xCFFFFFFF	PCI bus
0xFED00000-0xFED003FF	High precision event timer
0xD0604000-0xD0604FFF	Realtek PCIe GBE Family Controller
0xD0700000-0xD070FFFF	Intel(R) USB 3.0 eXtensible Host Controller
0xE0000000-0xEFFFFFFF	Motherboard resources
0xFED01000-0xFED01FFF	Motherboard resources
0xFED03000-0xFED03FFF	Motherboard resources
0xFED04000-0xFED04FFF	Motherboard resources
0xFED0C000-0xFED0FFFF	Motherboard resources
0xFED08000-0xFED08FFF	Motherboard resources
0xFED1C000-0xFED1CFFF	Motherboard resources
0xFEE00000-0xFEEFFFFFFF	Motherboard resources
0xFE000000-0xFEFFFFFFF	Motherboard resources
0xD0710000-0xD0713FFF	High Definition Audio Controller
0xD0714000-0xD071401F	Intel(R) Atom(TM)/Celeron(R)/Pentium(R) Processor Platform Control Unit - SMBus Port - 0F12
0xD0500000-0xD05FFFFF	Intel(R) Trusted Execution Engine Interface
0xD0400000-0xD04FFFFF	Intel(R) Trusted Execution Engine Interface
0xA0000-0xBFFFF	Intel(R) Atom(TM) Processor E3800 Series/Intel(R) Celeron(R) Processor N2920/J1900
0xA0000-0xBFFFF	PCI bus
0xC0000-0xDFFFF	PCI bus
0xE0000-0xFFFFF	PCI bus
0xD0600000-0xD06FFFFF	Intel(R) Atom(TM)/Celeron(R)/Pentium(R)

MEMORY MAP	ASSIGNMENT
	Processor PCI Express - Root Port 4 - 0F4E
0xD0600000-0xD06FFFFFFF	Realtek PCIe GBE Family Controller
0xFF000000-0xFFFFFFFF	Intel(R) 82802 Firmware Hub Device
0xE00000D0-0xE00000DB	Intel(R) Atom(TM)/Celeron(R)/Pentium(R) Processor MBI Device - 33BD
0xD0716000-0xD07167FF	Intel(R) Atom(TM)/Celeron(R)/Pentium(R) Processor AHCI - 0F23
0xD0000000-0xD03FFFFFFF	Intel(R) Atom(TM) Processor E3800 Series/Intel(R) Celeron(R) Processor N2920/J1900
0xC0000000-0xCFFFFFFF	Intel(R) Atom(TM) Processor E3800 Series/Intel(R) Celeron(R) Processor N2920/J1900
0xC0000000-0xCFFFFFFF	PCI bus
0xFED00000-0xFED003FF	High precision event timer
0xD0604000-0xD0604FFF	Realtek PCIe GBE Family Controller
0xD0700000-0xD070FFFF	Intel(R) USB 3.0 eXtensible Host Controller

Configuring WatchDog Timer

The I/O port address of the watchdog timer is 2E (hex) and 2F (hex). 2E (hex) is the address port. 2F (hex) is the data port. User must first assign the address of register by writing address value into address port 2E (hex), then write/read data to/from the assigned register through data port 2F (hex).

Configuration Sequence

To program F81866 configuration registers, the following configuration sequence must be followed:

(1) Enter the extended function mode

To place the chip into the Extended Function Mode, two successive writes of 0x87 must be applied to Extended Function Enable Registers (EFERs, i.e. 2Eh or 4Eh).

(2) Configure the configuration registers

The chip selects the Logical Device and activates the desired Logical Devices through Extended Function Index Register (EFIR) and Extended Function Data Register (EFDR). The EFIR is located at the same address as the EFER, and the EFDR is located at address (EFIR+1). First, write the Logical Device Number (i.e. 0x07) to the EFIR and then write the number of the desired Logical Device to the EFDR. If accessing the Chip (Global) Control Registers, this step is not required. Secondly, write the address of the desired configuration register within the Logical Device to the EFIR and then write (or read) the desired configuration register through the EFDR.

(3) Exit the extended function mode

To exit the Extended Function Mode, writing 0xAA to the EFER is required. Once the chip exits the Extended Function Mode, it is in the normal running mode and is ready to enter the configuration mode.

Code example for watch dog timer

Enable the watchdog timer and set the timeout interval to **30** seconds.

```
;----- Enter to extended function mode -----  
mov    dx, 2eh  
mov    al, 87h  
out    dx, al  
out    dx, al  
  
;----- Select Logical Device 7 of watchdog timer -----  
mov    al, 07h  
out    dx, al  
inc    dx  
mov    al, 07h  
out    dx, al  
  
;----- Enable Watch dog feature -----  
mov    al, 030h  
out    dx, al  
inc    dx  
mov    al, 01h  
out    dx, al  
  
;----- Enable Watch PME-----  
dec    dx  
mov    al, 0FAh  
out    dx, al  
inc    dx  
in     al, dx  
and    al, 51h  
out    dx, al  
  
;----- Set second as counting unit -----  
dec    dx  
mov    al, 0F5h  
out    dx, al  
inc    dx
```



```
in      al, dx
and     al, 30h
out     dx, al
; ----- Set timeout interval as 30seconds and start counting -----
dec     dx
mov     al, 0F6h
out     dx, al
inc     dx
mov     al, 1Eh
out     dx, al
; -----Exit the extended function mode -----
dec     dx
mov     al, 0AAh
out     dx, al
```

Flash BIOS Update

I. Prerequisites

- 1** Prepare a bootable media (e.g. USB storage device) which can boot system to DOS prompt.
- 2** Download and save the BIOS file (e.g. 67220PD4.bin) to the bootable device.
- 3** Copy AMI flash utility – AFUDOS.exe (v5.07.01) into the storage device.
- 4** Make sure the target system can first boot to the bootable device.
 - (1) Connect the bootable USB device.
 - (2) Turn on the computer and press <ESC> or during boot to enter BIOS Setup.
 - (3) The system will go into the BIOS setup menu.
 - (4) Select [**Boot**] menu.
 - (5) Select [**Hard Drive BBS Priorities**] and set the USB bootable device as the 1st boot device.
 - (6) Press **F4** to save the configuration and exit the BIOS setup menu.

Aptio Setup Utility - Copyright (C) 2013 American Megatrends, Inc.

Boot

Boot Option #1	[JetFlashTranscend 4...]	Sets the system boot order
Boot Option #2	[P0: WDC WD1600BEVT-...]	

◆+: Select Screen
↑↓: Select Item
Enter: Select
+/-: Change Opt.
F1: General Help
F2: Previous Values
F3: Optimized Defaults
F4: Save & Exit
ESC: Exit

Version 2.16.1242. Copyright (C) 2013 American Megatrends, Inc.

II. AFUDOS Command for System BIOS Update

AFUDOS.exe is the AMI firmware update utility; the command line is shown as below:

AFUDOS <ROM File Name> [option1] [option2]....

Users can type “**AFUDOS/ ?**” to see all the definition of each control options. The recommended options for BIOS ROM update include following parameters:

- /P:** Program main BIOS image.
- /B:** Program Boot Block.
- /N:** Program NVRAM.
- /X:** Don't check ROM ID.

III. BIOS Update Procedure

- 1** Use the bootable USB storage to boot up the system into the DOS command prompt.
- 2** Type "**AFUDOS 6722xxxx.bin /p /b /n /x**" and press enter to start the flash procedure. (xxxx means the BIOS revision part, ex. 1PD1...)
- 3** During the BIOS update procedure, you will see the BIOS update process status and its percentage. Beware! Do not turn off the system power or reset your computer when the entire update procedure are not complete; otherwise, the BIOS ROM may be crashed and the system will be unable to boot up next time.
- 4** After the BIOS update procedure is completed, the following messages will be shown:

```
C:\> AFUDOS 67221PD1.bin /p /b /n /x
+-----+
|          AMI Firmware Update Utility  v5.07.01          |
| Copyright (C) 2014 American Megatrends Inc. All Rights Reserved. |
+-----+
Reading flash ..... done
- ME Data Size Checking . ok
- FFS checksums ..... ok
Erasing Boot Block ..... done
Updating Boot Block ..... done
Verifying Boot Block ..... done
Erasing Main Block ..... done
Updating Main Block ..... done
Verifying Main Block ..... done
Erasing NVRAM Block ..... done
Updating NVRAM Block ..... done
Verifying NVRAM Block ..... done
C:>_
```

5. Restart the system and boot up with the new BIOS configurations.
6. The BIOS Update is completed after the system is restarted.
7. Reboot the system and verify if the BIOS version shown on the initialization screen has been updated.

