

PA-2019

Quick Reference Guide



Ver. Q4

All Rights Reserved. Copyright 2019

Packing Checklist

If you discover any item below are damaged or lost, please contact your vendor immediately.

- PA-2019 x1
- This Quick Reference Guide x1
- AC Power Adaptor x1
- Manual/Driver CD x1

Specifications

		6th Gen. Skylake	7th Gen. Kabylake
System	CPU Support	Intel® Core™ i5-6500 Intel® Core™ i3-6100 Pentium® G4400 Celeron® G3900	Intel® Core™ i7-7700 Intel® Core™ i5-7500 Intel® Core™ i3-7101E Pentium® G4560 Celeron® G3930E
	Core Logic	Intel® H110 Chipset	
	Memory	2 x DDR4 SO-DIMM slots (up to 32GB)	
	Network	10/100/1000Mbps Base-T Fast Ethernet	
	Power Supply	120 Watt power	
	BIOS	AMI SPI BIOS, 8Mbits with VGA BIOS	
	System Weight	6.8kg (POS + 2nd Display), 6.6kg (Normal Stand POS), 5.3kg (PPC)	
	Dimensions	367.49 x 281.95 x 303.04mm (Normal Stand POS) 417.24 x 352.38 x 215.31mm (POS + 8" 2nd Display) 367.49 x 281.95 x 74.88mm (PPC)	
	O.S. Support	Win10 / Win8.1 / Win7 / POSReady7 * 7th Gen. processor supports Win 10 only.	
	Storage	HDD	1 x 2.5" SATA HDD or SSD (option)
I/O Ports	USB	2 x USB 2.0 ports, 2 x USB 3.0 ports on rear	
	eSATA	1 x eSATA (external SATA) port	
	Serial Port	2 + 1(option) x DB9 (+5V/12V selectable), 1 x RJ45 (COM1)	
	LAN	1 x RJ-45	
	VGA	1 x DB-15 VGA Interface	
	Line-Out	1 x phone jack	
	Cash Drawer	1 + 1 (option, with Y cable) x RJ11 (+12V/+24V selectable)	
	DC IN	1 x 4 pin DC Power Jack	
Peripheral	Customer Display	VFD kit, 20 columns and 2 lines, each column is 5 x 7 dots	
	2nd Display	8" TFT LCD Monitor, 1024x768, 250nits	
	MSR & iButton	ISO I,II,III; JIS I,II	
	Fingerprint	8-bit grayscale reader	
Display	LCD	15" TFT XGA LCD	
	Max. Resolution	1024x768	
	Brightness	300 cd/m ²	
	Touchscreen	5-wire Analog Resistive or Projected Capacitive	
Environment	Tilt Angle	0 ~ 68 degree	
	EMC & Safety	CE / FCC	
	Operating Temp.	0°C ~ 35°C	
	Storage Temp.	-20°C ~ 60°C	
Humidity	20% ~ 90%		

System View

Unit: mm

Front View

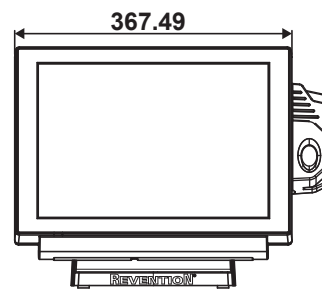

Rear View

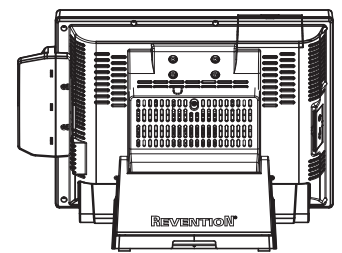

Side View

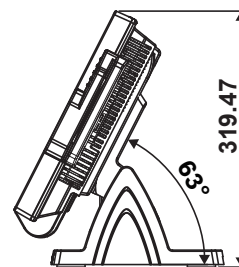

Quarter View

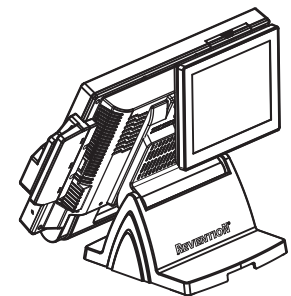

I/O View

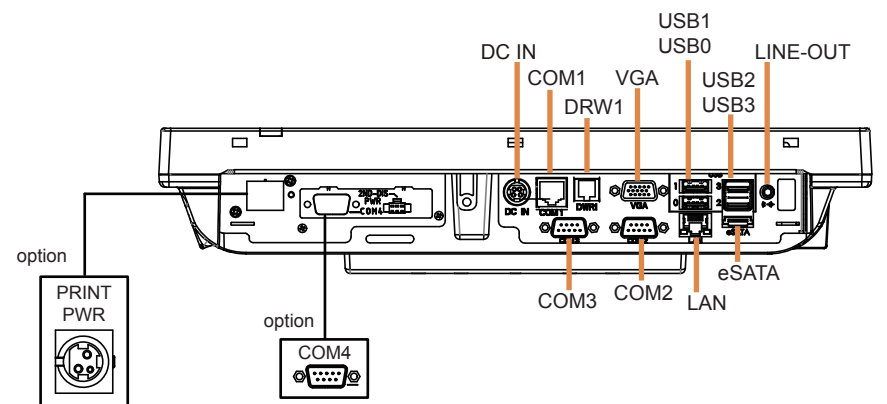

PA-2019

High Performance 15" POS Terminal

Easy Maintenance

Step 1:

Press the HDD cover and push it out.

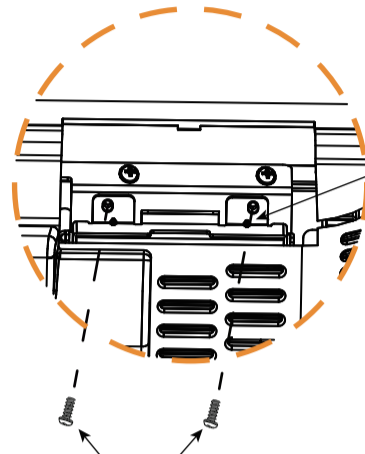
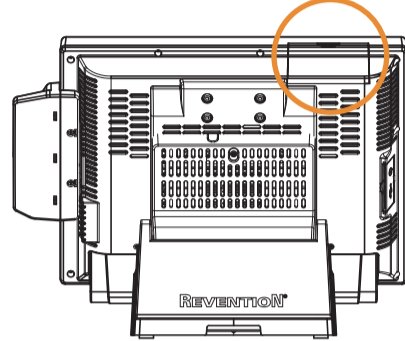
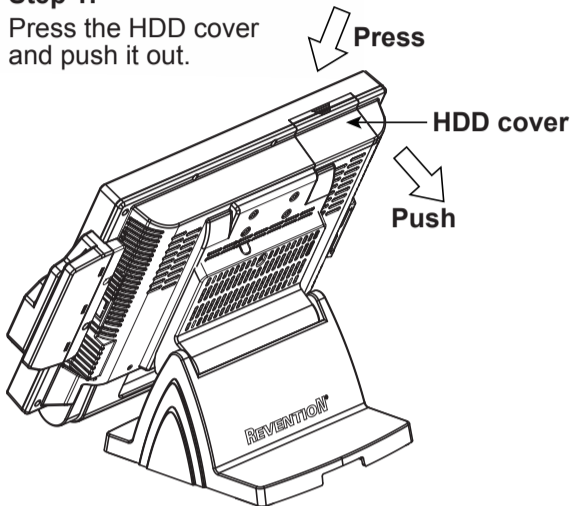

Step 2:

Release the two screws.

Step 3:

Pull out the HDD module.

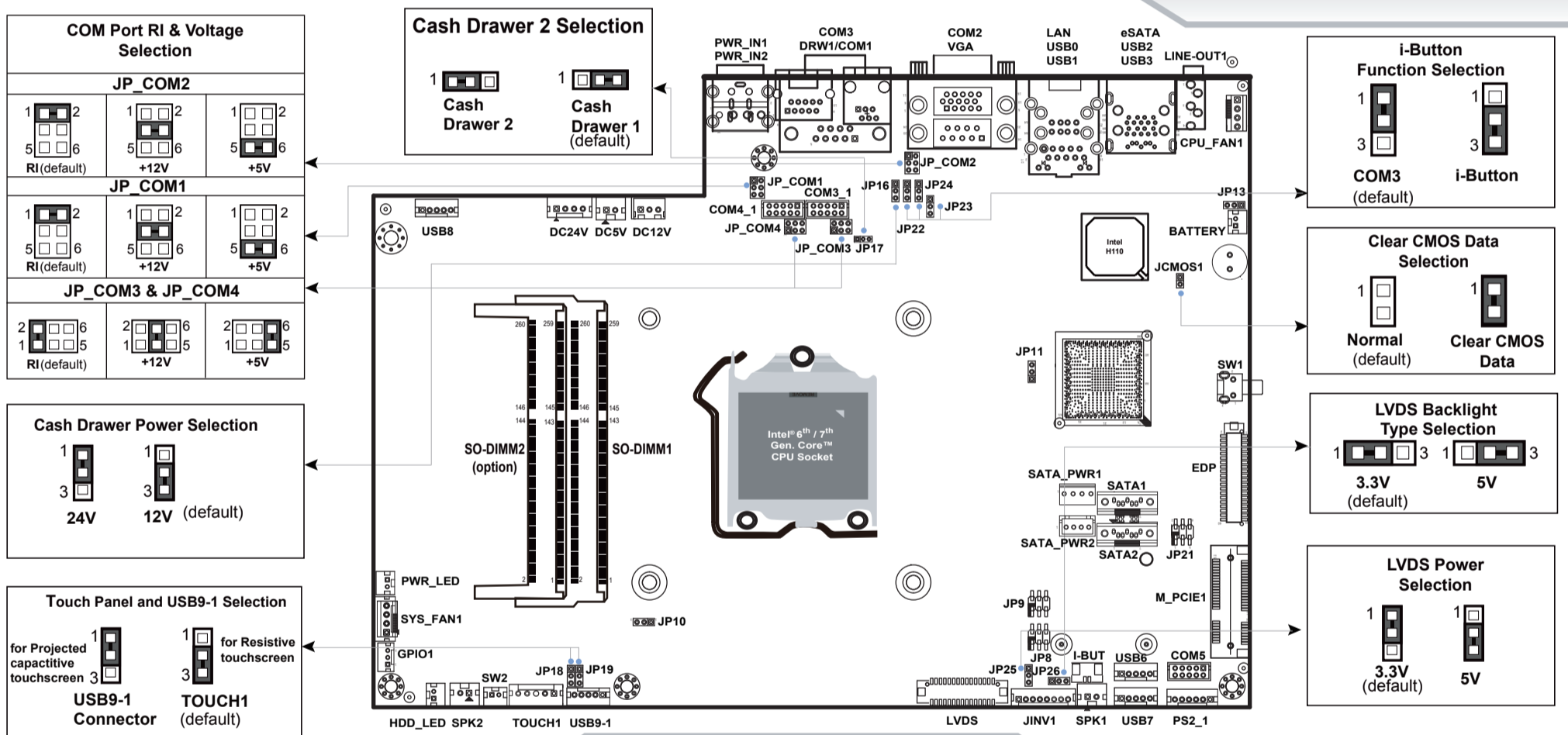
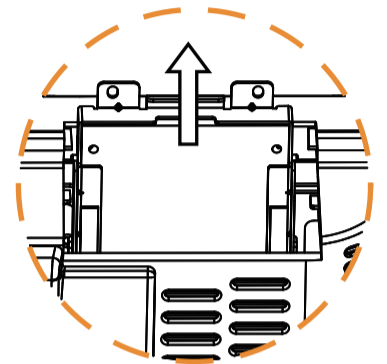

Safety Precaution

The following messages are reminders for safety on how to protect your systems from damages and to extend a long life of the system.

1. Check the Cable Voltage

- Make sure the range of operating voltage between AC 100V ~ 240V. Otherwise, the system could be damaged.

2. Environmental Conditions

- Place your PA-2019 on a sturdy, level surface. Be sure to allow enough space to have easy access around the system.
- Avoid extremely hot or cold place to install the system.
- Avoid exposure to sunlight for a long period of time or in an airtight space.
- Avoid the system from any heating device or using it outdoors in a cold winter day.
- Bear in mind that the operating ambient temperature is from 0 ~ 35°C (32 ~ 95°F).
- Avoid moving the system rapidly from a hot place to a cold place and vice versa because condensation may come from inside of the system.
- Place PA-2019 in strong vibration(s) may cause hard disk failure.
- Don't place the system close to any radio active device in case of signal interference.

3. Handling

- If the system isn't fully in DOS mode, adjust BIOS setting as the instruction: Advanced Chipset Feature => Boot display => choose "LFP".
- Avoid putting heavy objects on top of the system.
- Don't turn the system upside down. This may cause the hard drive to malfunction.

- Don't allow foreign objects to fall into this product.
- If water or other liquid spills into this product, unplug the power cord immediately.

4. Good Care

- When the outside of the case is stained, remove the stain with a neutral washing agent with a dry cloth.
- Never use strong agents such as benzene and thinner to clean the system. If heavy stains are present, moisten a cloth with diluted neutral washing agent or with alcohol and then wipe thoroughly with a dry cloth.
- If dust has been accumulated on the outside, remove it by using a special made vacuum cleaner for computers.
- Don't contact the surface of capacitive touch before entering your operation system, or capacitive touch may have position problems for electrostatics interface.
- Don't exchange the M/B battery by yourself or serious damage may incur.

CAUTION! Danger of explosion if battery is incorrectly replaced. Replace only with the same or equivalent type recommended by the manufacturer. Dispose of used batteries according to the manufacturer's instructions.

WARNING! Some internal parts of the system may have high electrical voltage. And therefore we strongly recommend that qualified engineers can open and disassemble the system. The LCD and Touchscreen are easily breakable, please handle them with extra care.