

USER MANUAL

BM-D025

**Mini-ITX Intel® 10th Gen. Core™
i9/i7/i5/i3/ Pentium® / Celeron® /
Xeon® W-1200 CPU Processor**

BM-D025 M1

BM-D025

Mini-ITX Intel[®] 10th Gen. Core[™] i9/i7/i5/i3/ Pentium[®] / Celeron[®] / Xeon[®] W-1200 CPU Processor

COPYRIGHT NOTICE & TRADEMARK

All trademarks and registered trademarks mentioned herein are the property of their respective owners.

This manual is copyrighted in Dec. 2021. You may not reproduce or transmit in any form or by any means, electronic, or mechanical, including photocopying and recording.

DISCLAIMER

This user's manual is meant to assist users in installing and setting up the board. The information contained in this document is subject to change without any notice.



CE NOTICE

This is a class A product. In a domestic environment this product may cause radio interference in which case the user may be required to take adequate measures.

FCC NOTICE

This equipment has been tested and found to comply with the limits for a Class A digital device, pursuant to part 15 of the FCC Rules. These limits are designed to provide reasonable protection against harmful interference when the equipment is operated in a commercial environment. This equipment generates, uses, and can radiate radio frequency energy and, if not installed and used in accordance with the instruction manual, may cause harmful interference to radio communications. Operation of this equipment in a residential area is likely to cause harmful interference in which case the user will be required to correct the interference at his own expense.

You are cautioned that any change or modifications to the equipment not expressly approve by the party responsible for compliance could void your authority to operate such equipment.

	<p>CAUTION: Danger of explosion may occur when the battery is incorrectly replaced. Replace the battery only with the same or equivalent type recommended by the manufacturer. Dispose of used batteries according to the manufacturer's instructions.</p>
	<p>CAUTION: Always touch the board components by the edges. Never touch components such as a processor by its pins. Take special cares while you are holding electronic circuit boards by the edges only. Do not touch BM-D025 components.</p>
	<p>WARNING: Some internal parts of BM-D025 may have high electrical voltage. We strongly recommend that only qualified engineers are allowed to service and disassemble the board. If any damages should occur on BM-D025 and are caused by unauthorized servicing, it will not be covered by the product warranty.</p>

Contents

1	Introduction	1-1
1.1	About This Manual	1-2
2	Getting Started	2-1
2.1	Package List.....	2-2
2.2	BM-D025 Specifications	2-3
2.3	Safety Precautions	2-6
3	Hardware Configuration	3-1
3.1	JUMPER & CONNECTOR QUICK REFERENCE TABLE	3-2
3.2	COMPONENT LOCATIONS	3-3
3.2.1	BM-D025 Top View.....	3-3
3.2.2	BM-D025 Jumper Setting	3-4
3.2.3	BM-D025 Bottom View	3-5
3.2.4	BM-D025 I/O View.....	3-6
3.3	HOW TO SET JUMPERS	3-7
3.4	SETTING CONNECTORS AND JUMPERS	3-9
3.4.1	COM1 and COM2 PORT (COM1, COM2)	3-9
3.4.2	COM3, COM4, COM5, COM6 CONNECTOR (COM3 ~ COM6).....	3-10
3.4.3	COM1, COM2 and COM4 PIN9 DEFINITION SELECTION GUIDE (JPCOM1, JPCOM2, JPCOM4).....	3-11
3.4.4	PS/2 COMBO & DUAL USB 2.0 PORT (KB_MS_USB1)	3-13
3.4.5	DISPLAYPORT (DP1)	3-14
3.4.6	DUAL DVI-D PORTS (DVI1)	3-15

3.4.7	FRONT PANEL CONNECTOR (JFP1).....	3-17
3.4.8	LAN & USB PORT (LAN1_USB1, LAN2_USB2)	3-18
3.4.9	LINE IN, LINE OUT, MIC IN PORT (AUDIO1).....	3-21
3.4.10	PRINTER PORT CONNECTOR (LPT1).....	3-22
3.4.11	FRONT PANEL AUDIO CONNECTOR (JAUDIO1).....	3-23
3.4.12	CASE OPEN CONNECTOR (JP5).....	3-24
3.4.13	M.2 SLOT (M2_SSD1)	3-25
3.4.14	PCI-E BUS (PCI_E1 (x16)).....	3-27
3.4.15	CPU / SYSTEM FAN CONNECTOR (CPU_FAN1, SYS_FAN1, SYS_FAN2).....	3-30
3.4.16	SERIAL ATA (SATA) CONNECTOR (SATA1, SATA2).....	3-31
3.4.17	INTERNAL USB 3.0 CONNECTOR (USB1)	3-32
3.4.18	POWER INPUT CONNECTOR (ATX_PWR1, ATX_PWR2)	3-33
3.4.19	LOW PIN COUNT (LPC) CONNECTOR (JLPC1).....	3-34
3.4.20	HARDWARE POWER FAILURE SELECTION (JP_AT1)	3-35
3.4.21	FLASH DESCRIPTOR OVERRIDE SELECTION (JP1)	3-36
3.4.22	PCH CONFIGURATION / RECOVERY SELECTION (JP4)	3-37
3.4.23	LPC CONNECTOR IRQ / GND SELECTION (JP7).....	3-38
3.4.24	CLEAR CMOS DATA SELECTION (JCMOS1)	3-39
4	Software Utilities	4-1
4.1	Introduction.....	4-2
4.2	Installing Intel® Chipset Software Installation Utility	4-3
4.3	Installing Graphics Driver Utility	4-4
4.4	Installing LAN Driver Utility.....	4-5
4.5	Installing Sound Driver Utility	4-6

4.6	Installing Intel® Management Engine Components Driver Installer	4-7
4.7	Installing Intel® Rapid Storage Utility.....	4-8
4.8	Installing Intel® Serial I/O Driver Utility	4-15
5	BIOS SETUP	5-1
5.1	Introduction.....	5-2
5.2	Accessing Setup Utility.....	5-3
5.3	Main.....	5-6
5.4	Advanced	5-8
5.4.1	Advanced – CPU Configuration	5-9
5.4.2	Advanced – PCH-FW Configuration.....	5-10
5.4.3	Advanced – Trusted Computing	5-11
5.4.4	Advanced – ACPI Settings	5-12
5.4.5	Advanced – Super IO Configuration.....	5-13
	Super IO Configuration – Serial Port 1 Configuration	5-14
	Super IO Configuration – Serial Port 2 Configuration	5-15
	Super IO Configuration – Serial Port 3 Configuration	5-16
	Super IO Configuration – Serial Port 4 Configuration	5-17
	Super IO Configuration – Serial Port 5 Configuration	5-18
	Super IO Configuration – Serial Port 6 Configuration	5-19
	Super IO Configuration – Parallel Port Configuration	5-20
5.4.6	Advanced – Hardware Monitor.....	5-21
	Smart Fan Mode Configuration	5-22
5.4.7	Advanced – Super IO Watchdog.....	5-23
5.4.8	Advanced – Secondary Super IO Configuration	5-24
	Advanced – Secondary Super IO Configuration – Serial Port 1 Configuration	5-25

Advanced – Secondary Super IO Configuration – Serial Port 2 Configuration	5-26
Advanced – Secondary Super IO Configuration – Serial Port 3 Configuration	5-27
Advanced – Secondary Super IO Configuration – Serial Port 4 Configuration	5-28
5.4.9 Advanced – S5 RTC Wake Settings [Fixed Time].....	5-29
Advanced – S5 RTC Wake Settings [Dynamic Time].....	5-30
5.4.10 Advanced – USB Configuration.....	5-31
5.4.11 Advanced – Network Stack Configuration	5-32
5.4.12 Advanced – NVMe Configuration	5-33
5.5 Chipset	5-34
5.5.1 Chipset – System Agent (SA) Configuration	5-35
System Agent (SA) Configuration – Memory Configuration	5-36
System Agent (SA) Configuration – Graphics Configuration.....	5-37
System Agent (SA) Configuration – PEG Port Configuration.....	5-38
5.5.2 Chipset – PCH IO Configuratioin.....	5-39
PCH-IO Configuration – PCI Express Configuration	5-40
PCH-IO Configuration – PCI Express Configuration – I210 LAN2	5-41
PCH-IO Configuration – PCI Express Configuration – M.2 PCI Express x4 M Key (for Q470E/W480E only)	5-42
PCH-IO Configuration – SATA Configuration	5-43
5.6 Security	5-44
5.7 Boot	5-46
5.8 Save & Exit.....	5-47

Appendix A Technical SummaryA-1

BM-D025 Block Diagram	A-2
Interrupt Map	A-3
I/O MAP	A-16
Memory Map	A-18
DMA Map	A-19
Configuring WatchDog Timer	A-20
Flash BIOS Update.....	A-22

Revision History

The revision history of BM-D025 User Manual is described below:

Version No.	Revision History	Date
M1	Initial Release	2021/12/21

1 Introduction

This chapter provides the introduction for the BM-D025 board as well as the framework of the user manual.

The following topic is included:

- About This Manual

1.1 About This Manual

Thank you for purchasing our BM-D025 board. BM-D025 provides faster processing speed, greater expandability and can handle more tasks than before. This manual is designed to assist you how to install and set up the whole board. It contains 5 chapters and 1 appendix. Users can configure the board according to their own needs. This user manual is intended for service personnel with strong hardware background. It is not intended for general users.

The following section outlines the structure of this user manual.

Chapter 1 Introduction

This chapter provides the introduction for BM-D025 board as well as the framework of the user manual.

Chapter 2 Getting Started

This chapter describes the package contents and outlines BM-D025 specifications. Read the safety reminders carefully on how to take care of BM-D025 properly.

Chapter 3 Hardware Configuration

This chapter outlines the locations of the motherboard components and their respective functions. You will learn how to set the jumpers and configure BM-D025 to meet your own needs.

Chapter 4 Software Utilities

This chapter contains helpful information for proper installations of the Intel[®] Chipset Software Installation Utility, Graphics Driver Utility, LAN Driver Utility, Sound Driver Utility, Intel[®] Management Engine Components Driver Installer, Intel[®] Rapid Storage Utility and Intel[®] Serial I/O Driver Utility.

Chapter 5 BIOS Setup

This chapter indicates you how to change the BIOS configurations.

Appendix A Technical Summary

This appendix provides the information about the allocation maps for BM-D025 block diagram, system resources, Watchdog Timer Configuration and Flash BIOS Update.

2 Getting Started

This chapter provides the information for BM-D025 board. It describes the package contents and outlines the BM-D025 specifications.

The following topics are included:

- Package List
- BM-D025 Specification
- Safety Precautions

Experienced users can go to Chapter 3 Hardware Configuration on page 3-1 for a quick start.

2.1 Package List

If you discover any of the items listed below are damaged or lost, please contact your local distributor immediately.

Item	Q'ty
BM-D025	1
Quick Reference Guide	1
Manual / Driver DVD	1
Mini Jumper (2 mm)	6
SATA Lock Cable (420 mm)	1
PS/2 KB and MS Cable (250 mm)	1
I/O Shield	1

2.2 BM-D025 Specifications

System	
CPU Support	<ul style="list-style-type: none"> ➤ LGA1200 socket for Intel® 10th Gen. Xeon® / Core™ i9 / i7 / i5 / i3 / Pentium® / Celeron® desktop CPU ➤ Target TDP 65W
CPU List	<ul style="list-style-type: none"> ➤ Xeon®: W-1290TE, W-1270TE, W-1250TE ➤ 10th Gen. Core™: i9-10900E(TE), i7-10700E(TE), i5-10500E(TE), i3-10100E(TE) ➤ Pentium®: G6400E, G6400TE ➤ Celeron®: G5900E, G5900TE
Chipset	<ul style="list-style-type: none"> ➤ Intel® W480E (supports Xeon® / Core™ CPU) ➤ Intel® Q470E / H420E (supports Core™ / Pentium® / Celeron® CPU)
Memory Support	<ul style="list-style-type: none"> ➤ 2 x SO-DIMM sockets, support 2933MHz DDR4 up to 64GB (W1-1290TE, W-1270TE, i9, i7 CPU) ➤ 2 x SO-DIMM sockets, support 2666MHz DDR4 (up to 64GB) (W-1250TE, i5, i3 CPU) ➤ 2 x SO-DIMM sockets, support 2400MHz DDR4 (up to 64GB) (Pentium® / Celeron® CPU) ➤ Supports ECC (Xeon®, i3 CPU)/non-ECC (all sku)
BIOS	<ul style="list-style-type: none"> ➤ AMI UEFI BIOS
Hardware Monitor	<ul style="list-style-type: none"> ➤ CPU, System FAN (FAN connector*2), 12V, 5V, 5Vsb, Vcore
Watchdog Timer	<ul style="list-style-type: none"> ➤ 1~255 seconds watchdog timer selectable
Power Supply	<ul style="list-style-type: none"> ➤ Supports ATX power (24+4 pins)
Power Consumption	<ul style="list-style-type: none"> ➤ +12V: 2.4A; -12V: 0.01A; +3.3V: 0.28A; +5V: 0.75A; 5Vsb: 0.06A
Speaker	<ul style="list-style-type: none"> ➤ 1 x internal buzzer
Dimensions	<ul style="list-style-type: none"> ➤ 244 x 244mm (9.6" x 9.6")
O.S. Support	<ul style="list-style-type: none"> ➤ Windows 10 IoT Enterprise LTSC 2019 ➤ Linux Ubuntu 20.04 LTS
Certifications	<ul style="list-style-type: none"> ➤ CE / FCC
I/O Ports	
SATA Interface	<ul style="list-style-type: none"> ➤ W480E and Q470E SKU: 2 x SATA III (6.0Gb/s) with RAID 0,1 ➤ H420E SKU: 2 x SATA III (6.0Gb/s) without RAID

USB	Total Number		8	
	Rear I/O	LAN1_USB1	2 x USB 3.0	
		LAN2_USB2	2 x USB 3.0	
		KB_MS_USB1	2 x USB 2.0	
Internal	USB_1	2 x USB 3.0		
Serial Ports	Total Number		6	
	Rear I/O, D-sub	COM1	RS-232/422/485	+5V/+12V/RI jumper selectable
		COM2	RS-232	
	Internal	COM3~6		N/A
Parallel Port	➤ 1 x LPT port (Wafer)			
LAN	➤ Dual LAN (2 x RJ45 on rear I/O) Supports Wake-On-LAN & PXE ➤ LAN1: Intel® PHY 219LM (GbE) ➤ LAN 2: Intel® LAN 210AT (GbE) (GbE)			
GPIO / DIO	➤ N/A			
FAN (Internal)	➤ 1 x CPU fan (4 pin) ➤ 1 x System Fan (4 pin) compatible to 3-pin Fan ➤ 1 x System fan (3 pin)			
Keyboard / Mouse	➤ 1 x PS/2 Combo connector for keyboard & mouse (rear I/O) Note: PS/2 Keyboard can work alone. If customer intends to insert PS/2 Keyboard and Mouse simultaneously, PS/2 extension cable attached in the packing must be used.			
Audio	➤ Mic In / Line In / Line Out (rear I/O)			
Expansion Bus	➤ 1 x PCIeX16 slot, support PCIe Gen3.			
M.2 Slot	➤ 1 x M.2 slot, M-Key, supports NVMe PCIeX4/X2 and SATA, for storage only without USB signal ➤ Supports 2242 only			

LPC	➤ 2 x 5 Pin Header, Pitch 2.0, support 80 port for debug & support BR-6061 board for extended COM 7~10.
Display	
Flexible Display	➤ 2 x DVI-D, 1 x DP (internal)
DVI-D (Rear I/O)	➤ 2 x DVI-D, up to 1920 x 1200 @60Hz
DP (Internal)	➤ 1 x DP, up to 4096 x 2304 @60Hz
Others	
Front Panel LED Indicator	➤ HDD LED, Power LED, Power Switch, Reset Switch ➤ On-board Power LED (Green)
Front Panel Audio	➤ 2 x 5 wafer, pitch 2.0mm. (for customized only)
TPM on board	➤ N/A
Case Open Detection	➤ Yes
Shock	➤ 20G, half sine, 11ms duration, non-operation
Vibration	➤ Non-operation: 0.5G, 5-500Hz, X, Y, Z axis
Environment	
Operating Temp.	➤ 0°C ~ 60°C (32°F ~ 140°F)
Storage Temp.	➤ -40°C ~ 85°C (-40°F ~ 185°F)
Operation Humidity	➤ 20%~ 90% (non-condensing)

2.3 Safety Precautions

Follow the instructions below to avoid your board from damages:

1. Keep your board away from static electricity on all occasions.
2. Prevent electric shock. Don't touch any components of this board when it is powered on. Always disconnect power when the board is not in use.
3. Disconnect power source when you change any hardware devices.
For instance, when you connect a jumper or install any cards, a surge of power may damage the electronic components or the whole board.

3 **Hardware Configuration**

This chapter contains helpful information about the jumper & connector settings, and component locations.

The following sections are included:

- Jumper & Connector Quick Reference Table
- Component Locations
- Configuration and Jumper Settings
- Connector Pin Assignments

3.1 JUMPER & CONNECTOR QUICK REFERENCE TABLE



JUMPER Description	NAME
Clear CMOS Data Selection	JCMOS1
Hardware Power Failure Selection	JP_AT1
COM Port RI/Voltage Selection	JPCOM1, JPCOM2,JPCOM4
Flash Descriptor Override Selection	JP1
PCH Configuration / Recovery Selection	JP4
LPC Connector IRQ / GND Selection	JP7

CONNECTOR Description	NAME
COM Port Connectors	COM1, COM2, COM3, COM4, COM5, COM6
Dual DVI-D Ports	DVI1
LAN & USB Ports	LAN1_USB1, LAN2_USB2
Internal USB 3.0 Connector	USB1
DisplayPort Connector	DP1
Printer Port Connector	LPT1
PS/2 Combo & Dual USB 2.0 Port	KB_MS_USB1
Audio Port Connector	AUDIO1, JAUDIO1
FAN Connector	CPU_FAN1, SYS_FAN1, SYS_FAN2
Front Panel Connector	JFP1
Case Open Connector	JP5
LPC Connector	JLPC1
M.2 Slot	M2_SSD1
PCIe Slot	PCI_E1
Power Input Connector	ATX_PWR1, ATX_PWR2
SATA Connector	SATA1, SATA2,

3.2 COMPONENT LOCATIONS

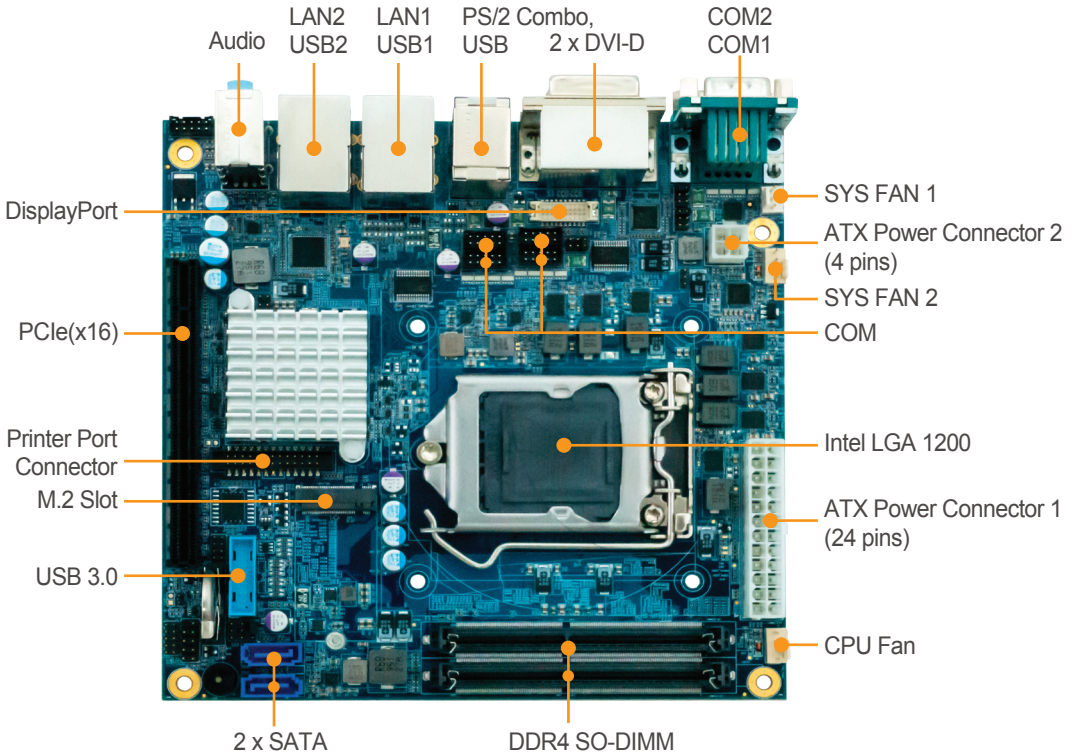
3.2.1 BM-D025 Top View



	WARNING: Always disconnect the power cord when you are working with connectors and jumpers on BM-D025. Make sure both the board and peripheral devices are turned OFF as sudden surge of power could damage sensitive components. Make sure the board is properly grounded.
	CAUTION: Observe precautions while handling electrostatic sensitive components. Make sure to ground yourself to prevent static charge while you are working on the connectors and jumpers. Use a grounding wrist strap and place all electronic components in any static-shielded devices.

3.2.2 BM-D025 Jumper Setting

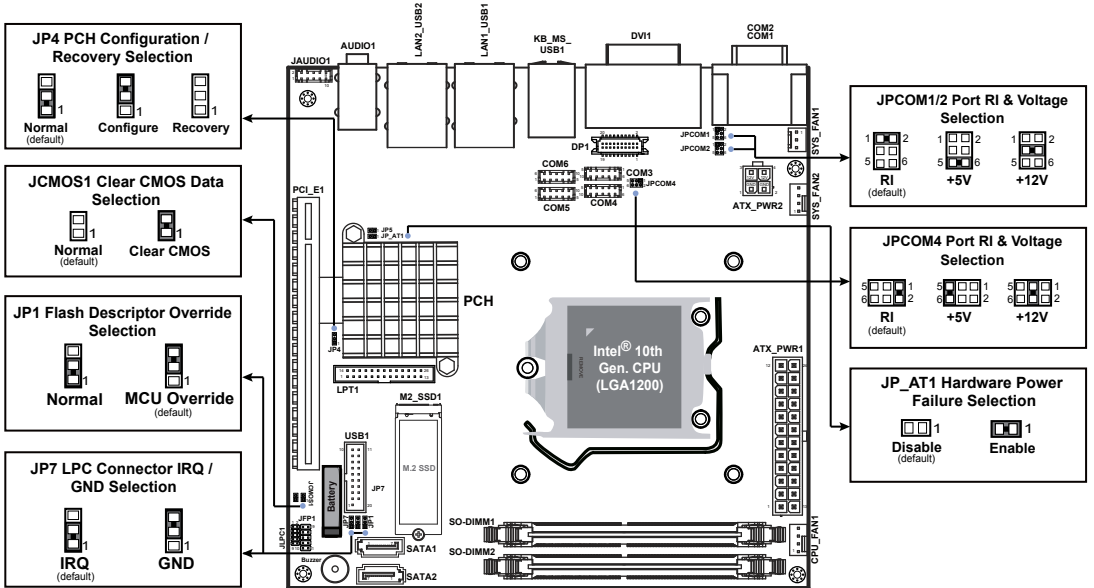
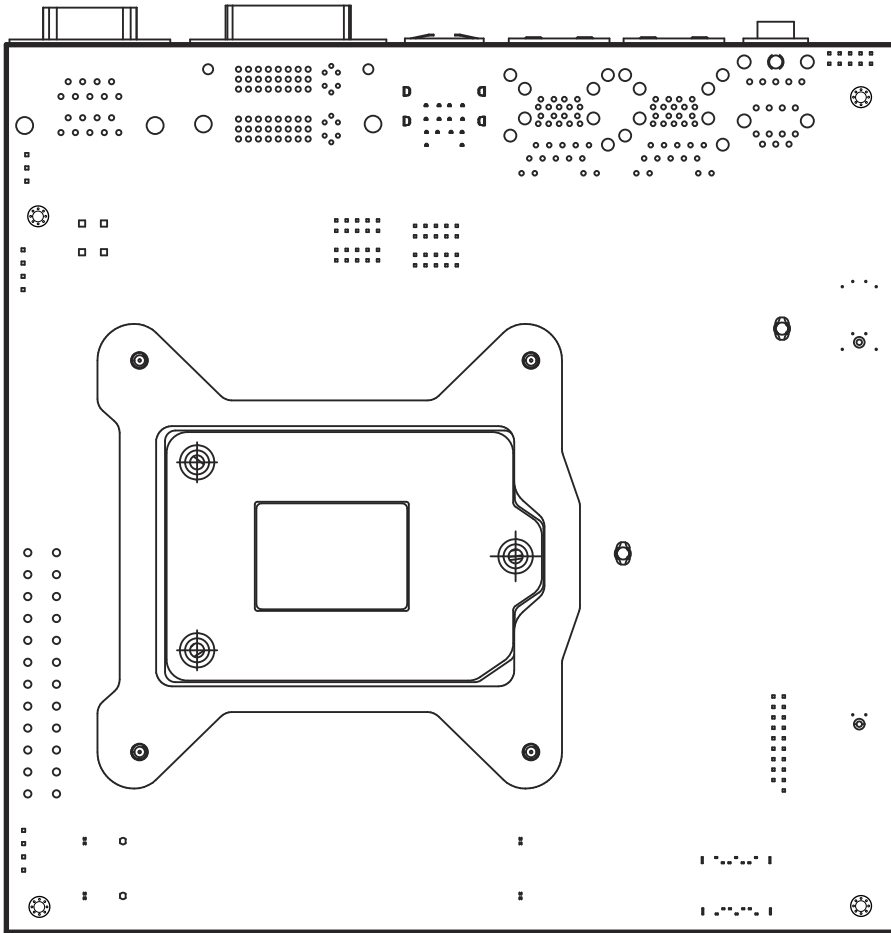
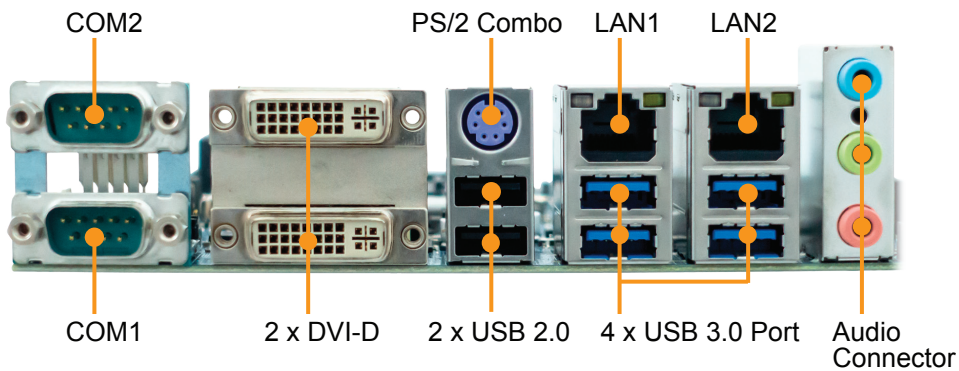

Figure 3-1. BM-D025 Component Location (Top View)

3.2.3 BM-D025 Bottom View



3.2.4 BM-D025 I/O View



3.3 HOW TO SET JUMPERS

You can configure your board by setting jumpers. A jumper consists of two or three metal pins with a plastic base mounted on the board. By using a small plastic "cap", (also known as the jumper cap (with a metal contact inside)), you are able to connect the pins. So you can set up your hardware configuration by "opening" or "closing" pins.

The jumper can be combined into sets that are called jumper blocks. When the jumpers are all in the block, you have to put them together to set up the hardware configuration. The figure below shows how this looks like.

JUMPERS AND CAPS

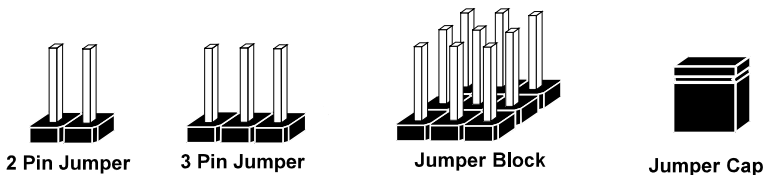

If a jumper has three pins (for examples, labeled PIN1, PIN2, and PIN3), you can connect PIN1 & PIN2 to create one setting by shorting. You can either connect PIN2 & PIN3 to create another setting. The same jumper diagrams are applied all through this manual. The figure below illustrates what the jumper diagrams look and what they represent.

Jumper Diagrams



Jumper Cap
looks like this

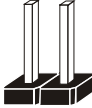

2 pin Jumper
looks like this

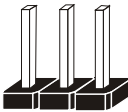

3 pin Jumper
looks like this

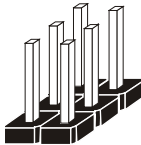

Jumper Block
looks like this

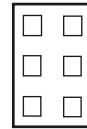

Jumper Settings



2 pin Jumper close(enabled)
Looks like this



1

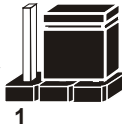

3 pin Jumper
2-3 pin close(enabled)
Looks like this



1



Jumper Block
1-2 pin close(enabled)
Looks like this

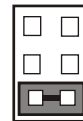

1 2

3.4 SETTING CONNECTORS AND JUMPERS

3.4.1 COM1 and COM2 PORT (COM1, COM2)

Port Location: COM1, COM2

Description: COM1 and COM2 Connectors (Default: RS-232)

COM1: COM1 is selectable as RS-232/422/485 mode under BIOS.

PIN	Signal		
	RS-232	RS-422	RS-485
1	DCD#	TX-	RS-485-
2	RX	TX+	RS-485+
3	TX	RX+	NC
4	DTR#	RX-	NC
5	GND	GND	GND
6	DSR#	NC	NC
7	RTS#	NC	NC
8	CTS#	NC	NC
9	RI#	NC	NC

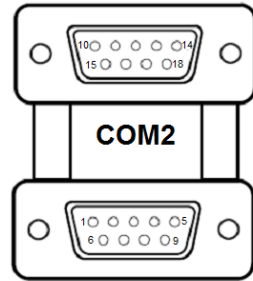

COM1

**COM1/
COM2**

COM2: COM2 Connector

The pin assignments are as follows:

PIN	Signal
	RS-232
10	DCD#
11	RX
12	TX
13	DTR#
14	GND
15	DSR#
16	RTS#
17	CTS#
18	RI#

Notes:

1. COM1 is selectable as RS-232, RS-422, RS-485 under BIOS setting.
2. Default setting is RS-232. Please see **Chapter 5 “Advanced – Super IO Configuration”** for details.

3.4.2 COM3, COM4, COM5, COM6 CONNECTOR (COM3 ~ COM6)

Connector Location: COM3, COM4, COM5, COM6

Description: COM Connector, fixed as RS-232

PIN	ASSIGNMENT	PIN	ASSIGNMENT
1	DCD#	6	DSR#
2	RX	7	RTS#
3	TX	8	CTS#
4	DTR#	9	RI#
5	GND	-	-

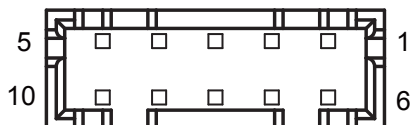

**COM3/
COM4**

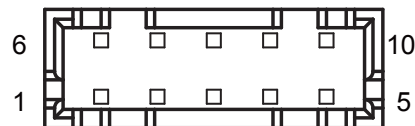

**COM5/
COM6**

Note:

1. COM1, COM2, COM4: COM1 Pin 9, COM2 Pin 18, COM4 pin 9 are selectable for RI, +5V or +12V by jumper setting. Default setting is RI. Please see “COM1, COM2 and COM4 PIN9 Definition Selection Guide” for details.

3.4.3 COM1, COM2 and COM4 PIN9 DEFINITION SELECTION GUIDE (JPCOM1, JPCOM2, JPCOM4)

Jumper Location: JPCOM1, JPCOM2

Description: COM1 and COM2 RI & Voltage Selection

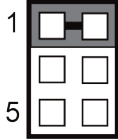
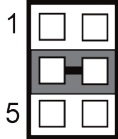
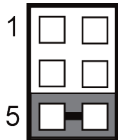
Selection	Jumper Setting (Pin Closed)	Jumper Illustration
RI	1-2 <i>(Default Setting)</i>	 <p>JPCOM1/JPCOM2</p>
+12V	3-4	 <p>JPCOM1/JPCOM2</p>
+5V	5-6	 <p>JPCOM1/JPCOM2</p>

Jumper Location: JPCOM4

Description: COM4 RI & Voltage Selection

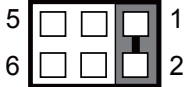
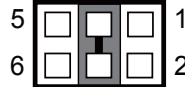
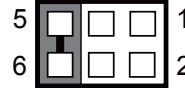
Selection	Jumper Setting (Pin Closed)	Jumper Illustration
RI	1-2 <i>(Default Setting)</i>	 <p>JPCOM4</p>
+12V	3-4	 <p>JPCOM4</p>
+5V	5-6	 <p>JPCOM4</p>

3.4.4 PS/2 COMBO & DUAL USB 2.0 PORT (KB_MS_USB1)

Port Location: KB_MS_USB1

Description: PS/2 Combo Port & Dual USB 2.0 Ports

Supports both keyboard and mouse functions on PS/2 by Y-cable.

PS/2:

PIN	ASSIGNMENT	PIN	ASSIGNMENT
9	GND	12	+5V
10	KB_DATA	13	KB_CLK
11	MS_DATA	14	MS_CLK

Dual USB 2.0:

PIN	ASSIGNMENT	PIN	ASSIGNMENT
1	GND	5	GND
2	USB D+	6	USB D+
3	USB D-	7	USB D-
4	+5V	8	+5V

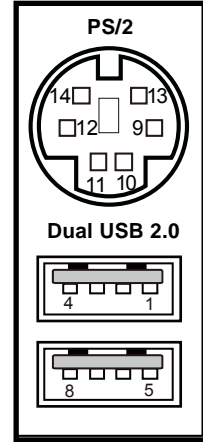

KB_MS_USB1

3.4.5 DISPLAYPORT (DP1)

Port Location: DP1

Description: DisplayPort

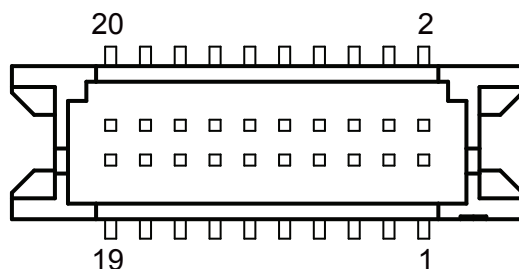

DP1

DP1 signals:

PIN	ASSIGNMENT	PIN	ASSIGNMENT
1	LANE 0_P	2	GND
3	LANE 0_N	4	LANE 1_P
5	GND	6	LANE 1_N
7	LANE 2_P	8	GND
9	LANE 2_N	10	LANE 3_P
11	GND	12	LANE 3_N
13	AUX_EN	14	GND
15	AUX_CH_P	16	HPD
17	AUX_CH_N	18	+3.3V
19	+5V	20	+3.3V

3.4.6 DUAL DVI-D PORTS (DVI1)

Port Location: DVI1 (rear I/O)

Description: 2 x DVI (Digital Visual Interface) Integrated Connectors
(Supports only DVI-D signals)

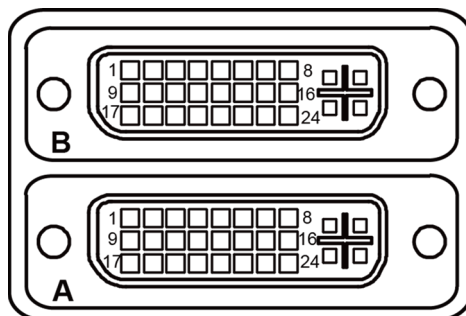

DVI1

DVI1 connector signals (A):

PIN	ASSIGNMENT	PIN	ASSIGNMENT
A1	TMDS_D2-	A13	NC
A2	TMDS_D2+	A14	+5V
A3	GND	A15	GND
A4	NC	A16	TMDS_HPD
A5	NC	A17	TMDS_D0-
A6	TMDS_CLK	A18	TMDS_D0+
A7	TMDS_DATA	A19	GND
A8	NC	A20	NC
A9	TMDS_D1-	A21	NC
A10	TMDS_D1+	A22	GND
A11	GND	A23	TMDS_D3+
A12	NC	A24	TMDS_D3-

DVI1 connector signals (B):

PIN	ASSIGNMENT	PIN	ASSIGNMENT
B1	TMDS_D2-	B13	NC
B2	TMDS_D2+	B14	+5V
B3	GND	B15	GND
B4	NC	B16	TMDS_HPDP
B5	NC	B17	TMDS_D0-
B6	TMDS_CLK	B18	TMDS_D0+
B7	TMDS_DATA	B19	GND
B8	NC	B20	NC
B9	TMDS_D1-	B21	NC
B10	TMDS_D1+	B22	GND
B11	GND	B23	TMDS_D3+
B12	NC	B24	TMDS_D3-

3.4.7 FRONT PANEL CONNECTOR (JFP1)

Connector Location: JFP1

Description: Front Panel Connector

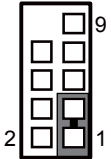
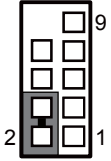
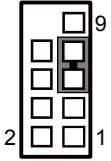
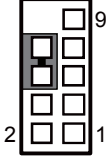
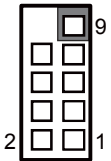
SELECTION	PIN & ASSIGNMENT	JUMPER SETTINGS	JUMPER ILLUSTRATION
HDD LED	1. HDD_LED+	1-3	 <p>JFP1</p>
	3. HDD_LED-		
Power LED	2. PWR_LED+	2-4	 <p>JFP1</p>
	4. PWR_LED-		
Reset Button	5. GND	5-7	 <p>JFP1</p>
	7. RST_BTN		
Power Button	6. PWR_BTN	6-8	 <p>JFP1</p>
	8. GND		
+5V	9. VCC5	9	 <p>JFP1</p>

3.4.8 LAN & USB PORT (LAN1_USB1, LAN2_USB2)

Dual LAN ports are provided to support 10/100/1000Mbps, RJ45, rear I/O, and supports Wake-On-LAN & PXE.

Port Location: LAN1_USB1

Description: LAN & Two USB 3.0 Ports

LAN1: Intel® PHY 219-LM (10/100/1000 Mbps)

Green/Orange Yellow

LAN1 pin assignment:

PIN	ASSIGNMENT
1	MDI_P0
2	MDI_N0
3	MDI_P1
4	MDI_N1
5	MDI_P2
6	MDI_N2
7	MDI_P3
8	MDI_N3

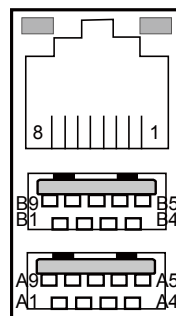

LAN1_USB1

LAN1 LED Indicator:

Left Side LED

Green Color On7	10/100 LAN Speed Indicator
Orange Color On8	Giga LAN Speed Indicator
Off	No LAN Switch/HUB connected

Right Side LED

Yellow Color Blinking	LAN Message Active
Off	No LAN Message Active

USB 3.0 signals:

PIN	ASSIGNMENT	PIN	ASSIGNMENT
A1	+5V	A9	USB_TX_P
A2	USB D-	A8	USB_TX_N
A3	USB D+	A7	GND
A4	GND	A6	USB_RX_P
-	-	A5	USB_RX_N

PIN	ASSIGNMENT	PIN	ASSIGNMENT
B1	+5V	B9	USB TX P
B2	USB D-	B8	USB TX N
B3	USB D+	B7	GND
B4	GND	B6	USB RX P
-	-	B5	USB RX N

Port Location: LAN2_USB2

Description: LAN & Two USB 3.0 Ports

LAN2: Intel® PHY 211AT (10/100/1000 Mbps)

LAN2 Pin Assignment:

PIN	ASSIGNMENT
1	MDI_P0
2	MDI_N0
3	MDI_P1
4	MDI_N1
5	MDI_P2
6	MDI_N2
7	MDI_P3
8	MDI_N3

Green/Orange Yellow

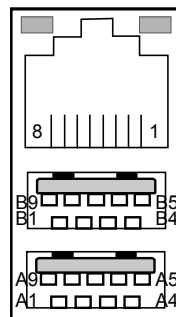

LAN2_USB2

LAN2 LED Indicator:

Left Side LED

Green Color On7	10/100 LAN Speed Indicator
Orange Color On8	Giga LAN Speed Indicator
Off	No LAN Switch/HUB connected

Right Side LED

Yellow Color Blinking	LAN Message Active
Off	No LAN Message Active

USB 3.0 signals:

PIN	ASSIGNMENT	PIN	ASSIGNMENT
A1	+5V	A9	USB TX P
A2	USB D-	A8	USB TX N
A3	USB D+	A7	GND
A4	GND	A6	USB RX P
-	-	A5	USB RX N

PIN	ASSIGNMENT	PIN	ASSIGNMENT
B1	+5V	B9	USB TX P
B2	USB D-	B8	USB TX N
B3	USB D+	B7	GND
B4	GND	B6	USB RX P
-	-	B5	USB RX N

3.4.9 LINE IN, LINE OUT, MIC IN PORT (AUDIO1)

Port Location: AUDIO1

Description: Line In, Line Out & Microphone

Line In:

PIN	ASSIGNMENT
32	HD_LINE-IN-L
33	GND
34	GND
35	HD_LINE-IN-R

Line Out:

PIN	ASSIGNMENT
22	HD_LINE-OUT-L
23	GND
24	GND
25	HD_LINE-OUT-R

Mic In:

PIN	ASSIGNMENT
2	HD_MIC-L
3	GND
1	GND
4	GND
5	HD_MIC-R

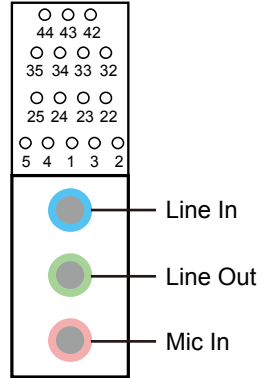

AUDIO1

3.4.10 PRINTER PORT CONNECTOR (LPT1)

Connector Location: LPT1

Description: Printer Port Connector



LPT1

PIN	ASSIGNMENT	PIN	ASSIGNMENT
1	PRN_STRB#	14	PRN_AFD
2	PRN_D0	15	PRN_ERR#
3	PRN_D1	16	PRN_INIT
4	PRN_D2	17	PRN_SLIN
5	PRN_D3	18	GND
6	PRN_D4	19	GND
7	PRN_D5	20	GND
8	PRN_D6	21	GND
9	PRN_D7	22	GND
10	PRN_ACK#	23	GND
11	PRN_BUSY	24	GND
12	PRN_PE	25	GND
13	PRN_SLCT	26	GND

3.4.11 FRONT PANEL AUDIO CONNECTOR (JAUDIO1)

Connector Location: JAUDIO1

Description: Front Panel Audio Connector

PIN	ASSIGNMENT	PIN	ASSIGNMENT
1	MIC1-L	2	GND
3	LINE-IN-L	4	GND
5	LINE-OUT-L	6	MIC1-R
7	GND	8	LINE-IN-R
9	GND	10	LINE-OUT-R

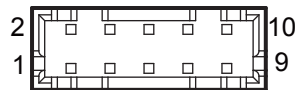

JAUDIO1

Note: JAUDIO1 is only supported in BM-D025-Z0N.

3.4.12 CASE OPEN CONNECTOR (JP5)

Connector Location: JP5

Description: Case Open Connector

PIN	ASSIGNMENT
1	COPEN#
2	GND



JP5

3.4.13 M.2 SLOT (M2_SSD1)

Connector Location: M2_SSD1

Description: M.2 M-key slot supports PCIeX4/X2 and 2242/2260/2280 size.

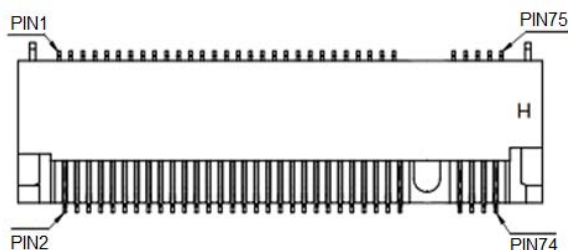

M2_SSD1

PIN	ASSIGNMENT	PIN	ASSIGNMENT
1	GND	2	+3.3V
3	GND	4	+3.3V
5	PE_RX_N3	6	NC
7	PE_RX_P3	8	NC
9	GND	10	NC
11	PE_TX_N3	12	+3.3V
13	PE_TX_P3	14	+3.3V
15	GND	16	+3.3V
17	PE_RX_N2	18	+3.3V
19	PE_RX_P2	20	NC
21	GND	22	NC
23	PE_TX_N2	24	NC
25	PE_TX_P2	26	NC
27	GND	28	NC
29	PE_RX_N1	30	NC
31	PE_RX_P1	32	NC
33	GND	34	NC
35	PE_TX_N1	36	NC
37	PE_TX_P1	38	NC
39	GND	40	NC
41	PE_RX_N0 / SATA	42	NC
43	PE_RX_P0 / SATA	44	NC
45	GND	46	NC
47	PE_TX_N0 / SATA	48	NC
49	PE_TX_P0 / SATA	50	PERST#
51	GND	52	CLKREQ#

PIN	ASSIGNMENT	PIN	ASSIGNMENT
53	REFCLK_N	54	PEWAKE#
55	REFCLK_P	56	NC
57	GND	58	NC
59	NC	60	NC
61	NC	62	NC
63	NC	64	NC
65	NC	66	NC
67	NC	68	NC
69	PE-NC / SATA-GND	70	+3.3V
71	GND	72	+3.3V
73	GND	74	+3.3V
75	GND	-	-

3.4.14 PCIE BUS (PCI_E1 (x16))

Connector Location: PCI_E1

Description: 164-pin PCIE Bus (x16)

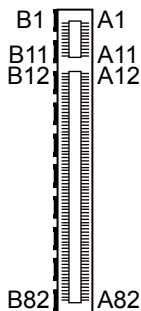

PCI_E1

PIN	ASSIGNMENT	PIN	ASSIGNMENT
B1	+12V	A1	PRSNT#1
B2	+12V	A2	+12V
B3	+12V	A3	+12V
B4	GND	A4	GND
B5	SMB_CLK	A5	NC
B6	SMB_DATA	A6	NC
B7	GND	A7	NC
B8	+3.3V	A8	NC
B9	NC	A9	+3.3V
B10	+3.3V_AUX	A10	+3.3V
B11	WAKE#	A11	PERST#
B12	RSVD	A12	GND
B13	GND	A13	REFCLK+
B14	HSOP0	A14	REFCLK-
B15	HSOP0	A15	GND
B16	GND	A16	HSIP0
B17	PRSNT#2	A17	HSIN0
B18	GND	A18	GND
B19	HSOP1	A19	RSVD
B20	HSOP1	A20	GND
B21	GND	A21	HSIP1
B22	GND	A22	HSIN1
B23	HSOP2	A23	GND
B24	HSOP2	A24	GND

PIN	ASSIGNMENT	PIN	ASSIGNMENT
B25	GND	A25	HSIP2
B26	GND	A26	HSIN2
B27	HSOP3	A27	GND
B28	HSOP3	A28	GND
B29	GND	A29	HSIP3
B30	RSVD	A30	HSIN3
B31	PRSNT#2	A31	GND
B32	GND	A32	RSVD
B33	HSOP4	A33	RSVD
B34	HSOP4	A34	GND
B35	GND	A35	HSIP4
B36	GND	A36	HSIN4
B37	HSOP5	A37	GND
B38	HSOP5	A38	GND
B39	GND	A39	HSIP5
B40	GND	A40	HSIN5
B41	HSOP6	A41	GND
B42	HSOP6	A42	GND
B43	GND	A43	HSIP6
B44	GND	A44	HSIN6
B45	HSOP7	A45	GND
B46	HSOP7	A46	GND
B47	GND	A47	HSIP7
B48	PRSNT#2	A48	HSIN7
B49	GND	A49	GND
B50	HSOP8	A50	RSVD
B51	HSOP8	A51	GND
B52	GND	A52	HSIP8
B53	GND	A53	HSIN8
B54	HSOP9	A54	GND
B55	HSOP9	A55	GND
B56	GND	A56	HSIP9
B57	GND	A57	HSIN9
B58	HSOP10	A58	GND
B59	HSOP10	A59	GND
B60	GND	A60	HSIP10
B61	GND	A61	HSIN10
B62	HSOP11	A62	GND
B63	HSOP11	A63	GND
B64	GND	A64	HSIP11

PIN	ASSIGNMENT	PIN	ASSIGNMENT
B65	GND	A65	HSIN11
B66	HSOP12	A66	GND
B67	HSOP12	A67	GND
B68	GND	A68	HSIP12
B69	GND	A69	HSIN12
B70	HSOP13	A70	GND
B71	HSOP13	A71	GND
B72	GND	A72	HSIP13
B73	GND	A73	HSIN13
B74	HSOP14	A74	GND
B75	HSIN14	A75	GND
B76	GND	A76	HSIP14
B77	GND	A77	HSIN14
B78	HSIP15	A78	GND
B79	HSIN15	A79	GND
B80	GND	A80	HSIP15
B81	PRSENT#2	A81	HSIN15
B82	RSVD	A82	GND

3.4.15 CPU / SYSTEM FAN CONNECTOR (CPU_FAN1, SYS_FAN1, SYS_FAN2)

Connector Location: CPU_FAN1

Description: CPU Fan Connector (CPU_FAN1)

PIN	ASSIGNMENT
1	GND
2	+12V
3	CPU_FANTAC
4	CPU_FANCTRL

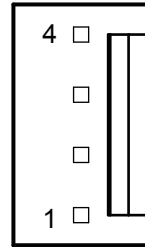

CPU_FAN1

Connector Location: SYS_FAN1

Description: System Fan Connector (SYS_FAN1)

PIN	ASSIGNMENT
1	GND
2	+12V
3	NC

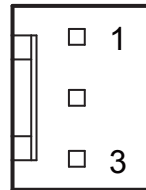

SYS_FAN1

Connector Location: SYS_FAN2

Description: System Fan Connector 2 (SYS_FAN2)

PIN	ASSIGNMENT
1	GND
2	+12V
3	SYS_FANTAC
4	SYS_FANCTRL

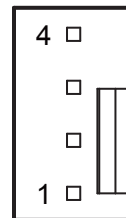

SYS_FAN2

3.4.16 SERIAL ATA (SATA) CONNECTOR (SATA1, SATA2)

Connector Location: SATA1, SATA2

Description: SATA Connectors

Pin Assignments for SATA1, SATA2:

PIN	ASSIGNMENT
1	GND
2	SATA_TX_P
3	SATA_TX_N
4	GND
5	SATA_RX_N
6	SATA_RX_P
7	GND

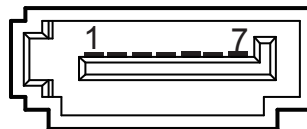

SATA1

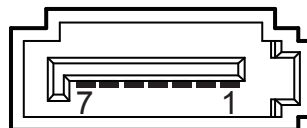

SATA2

3.4.17 INTERNAL USB 3.0 CONNECTOR (USB1)

Connector Location: USB1

Description: Internal USB 3.0 Connector

PIN	ASSIGNMENT	PIN	ASSIGNMENT
1	+5V	11	USB D+
2	USB RX N	12	USB D-
3	USB RX P	13	GND
4	GND	14	USB TX P
5	USB TX N	15	USB TX N
6	USB TX P	16	GND
7	GND	17	USB RX P
8	USB D-	18	USB RX N
9	USB D+	19	+5V
10	GND	-	-

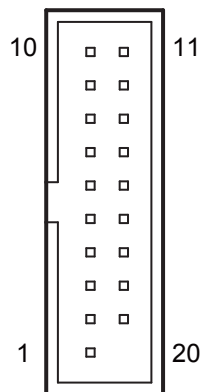

USB1

3.4.18 POWER INPUT CONNECTOR (ATX_PWR1, ATX_PWR2)

Connector Location: ATX_PWR1

Description: ATX Power Connector

PIN	ASSIGNMENT	PIN	ASSIGNMENT
1	+3.3V	13	+3.3V
2	+3.3V	14	-12V
3	GND	15	GND
4	+5V	16	PSON
5	GND	17	GND
6	+5V	18	GND
7	GND	19	GND
8	POK	20	-5V
9	+5V_SB	21	+5V
10	+12V	22	+5V
11	+12V	23	+5V
12	+3.3V	24	GND

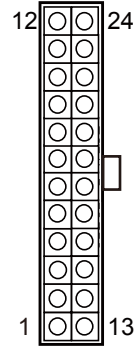

ATX_PWR1

Connector Location: ATX_PWR2

Description: Power Connector

PIN	ASSIGNMENT	PIN	ASSIGNMENT
3	+12V	4	+12V
1	GND	2	GND

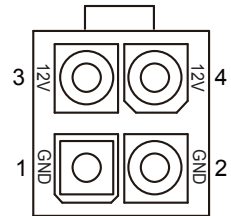

ATX_PWR2

3.4.19 LOW PIN COUNT (LPC) CONNECTOR (JLPC1)

Connector Location: JLPC1

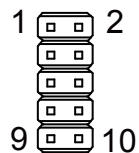

Description: LPC Connector

PIN	ASSIGNMENT	PIN	ASSIGNMENT
1	CLK	2	GND
3	FRAME	4	SERIRQ / GND
5	RESET	6	LAD0
7	LAD3	8	LAD2
9	+3.3V	10	LAD1





JLPC1

3.4.20 HARDWARE POWER FAILURE SELECTION (JP_AT1)**Jumper Location:** JP_AT1**Description:** Hardware Power Failure Selection

Selection	Jumper Setting (Pin Closed)	Jumper Illustration
Enable	1-2	 JP_AT1
Disable	Open <i>(Default Setting)</i>	 JP_AT1

3.4.21 FLASH DESCRIPTOR OVERRIDE SELECTION (JP1)**Jumper Location:** JP1**Description:** Flash Descriptor Override Selection

Selection	Jumper Setting (Pin Closed)	Jumper Illustration
Normal	1-2	 <p style="text-align: right;">1</p> <p style="text-align: center;">JP1</p>
MCU Override	2-3 (Default Setting)	 <p style="text-align: right;">1</p> <p style="text-align: center;">JP1</p>

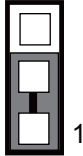
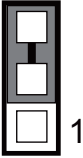
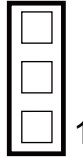

3.4.22 PCH CONFIGURATION / RECOVERY SELECTION (JP4)**Jumper Location: JP4****Description:** PCH Configuration / Recovery Selection

Selection	Jumper Setting (Pin Closed)	Jumper Illustration
Normal	1-2 <i>(Default Setting)</i>	 JP4
Configure	2-3	 JP4
Recovery	Open	 JP4

3.4.23 LPC CONNECTOR IRQ / GND SELECTION (JP7)

Jumper Location: JP7

Description: LPC Connector IRQ / GND Selection



Selection	Jumper Setting (Pin Closed)	Jumper Illustration
IRQ	1-2 <i>(Default Setting)</i>	 <p>JP7</p>
GND	2-3	 <p>JP7</p>

3.4.24 CLEAR CMOS DATA SELECTION (JCMOS1)

Jumper Location: JCMOS1

Description: Clear CMOS Data Selection

- Step 1.** Remove the main power of the PC.
- Step 2.** Close JCMOS1 (pins 1-2) for 6 seconds by a cap.
- Step 3.** Remove the cap which is just used on JCMOS1 (1-2), so that JCMOS1 returns to “OPEN”.
- Step 4.** Power on the PC and the PC will then auto-reboot for once in order to set SoC’s register.
- Step 5.** Done!

Selection	Jumper Setting (Pin Closed)	Jumper Illustration
Normal	Open (Default Setting)	 JCMOS1
Clear CMOS	1-2	 JCMOS1

4 Software Utilities

This chapter provides the detailed information that guides users to install driver utilities. The following topics are included:

- Installing Intel® Chipset Software Installation Utility
- Installing Graphics Driver Utility
- Installing LAN Driver Utility
- Installing Sound Driver Utility
- Installing Intel® Management Engine Components Driver Installer
- Installing Intel® Rapid Storage Utility
- Installing Intel® Serial I/O Driver Utility

4.1 Introduction

Enclosed with the BM-D025 Series package is our driver utilities contained in a DVD-ROM disk. Refer to the following table for driver locations:

Filename (Assume that DVD-ROM drive is D :)	Purpose
D:\Driver\Platform\1_Main Chip\Win10(64Bit)	Intel® Chipset Device Software installer
D:\Driver\Platform\2_Graphics\Win10 (64Bit)	Intel® HD Graphics Driver installer
D:\Driver\Platform\3_Sound\Win10 (64Bit)	Realtek® ALC888S HD Audio Driver installer
D:\Driver\Platform\4_ME\Win10 (64Bit)	Intel® Management Engine Driver installer for W480E/Q470/H420E
D:\Driver\Platform\5_LAN Chip\Win10 (64Bit)	Intel® LAN Driver installer
D:\Driver\Platform\6_Serial IO\Win10 (64Bit)	Intel® Serial IO Driver installer
D:\Driver\Platform\7_RAID\Win10 (64Bit)	Intel® RST Driver installer for RAID

Notes:

1. Install the driver utilities immediately after the OS installation is completed.
2. After the Intel® RST Utility is installed, you must execute Windows 10 LTSC 2019 update procedure. The Intel® RST Utility can be activated successfully only after the Windows Update procedure is finished.

For more details on the installation sequence, refer to the Readme.txt file.

4.2 Installing Intel® Chipset Software Installation Utility

Introduction

The Intel® Chipset Software Installation Utility installs the Windows *.INF files to the target system. These files outline to the operating system how to configure the Intel® chipset components in order to ensure that the following functions work properly:

- Core PCI and ISAPNP Services
- PCI-e Support
- SATA Storage Support
- USB Support
- Identification of Intel® Chipset Components in the Device Manager

Intel® Chipset Software Installation Utility

The utility pack is to be installed only for Windows 10 (64-bit), and it should be installed immediately after the OS installation is finished. Please follow the steps below:

- 1** Connect the USB DVD-ROM device to BM-D025 and insert the driver disk.
- 2** Enter the **Main Chip** folder where the Chipset driver is located.
- 3** Click **SetupChipset.exe** file for driver installation.
- 4** Follow the on-screen instructions to install the driver.
- 5** Once the installation is completed, shut down the system and restart BM-D025 for the changes to take effect.

4.3 Installing Graphics Driver Utility

To install the Graphics driver utility, follow the steps below:

- 1** Connect the USB DVD-ROM device to BM-D025 and insert the driver disk.
- 2** Enter the **Graphics** folder where the driver is located.
- 3** Click the **igxpin.exe** file for driver installation.
- 4** Follow the on-screen instructions to complete the installation.
- 5** Once the installation is completed, shut down the system and restart BM-D025 for the changes to take effect.

4.4 Installing LAN Driver Utility

Enhanced with LAN function, BM-D025 supports various network adapters. To install the LAN Driver, follow the steps below:

- 1** Connect the USB DVD-ROM device to BM-D025 and insert the driver disk.
- 2** Enter the **LAN Chip** folder where the driver is located.
- 3** Click **Autorun.exe** file for driver installation.
- 4** Follow the on-screen instructions to complete the installation.
- 5** Once the installation is completed, shut down the system and restart BM-D025 for the changes to take effect.

4.5 Installing Sound Driver Utility

To install the Sound Driver, follow the steps below:

- 1** Connect the USB DVD-ROM device to BM-D025 and insert the driver disk.
- 2** Open the **Sound** folder where the driver is located.
- 3** Click the **Setup.exe** file for driver installation.
- 4** Follow the on-screen instructions to complete the installation.
- 5** Once the installation is completed, shut down the system and restart BM-D025 for the changes to take effect.

4.6 Installing Intel® Management Engine Components Driver Installer

Installation Instructions for Intel® Management Engine Components Driver Installer

- 1** Connect the USB DVD-ROM device to BM-D025 and insert the driver disk.
- 2** Enter the **ME** folder where the driver is located.
- 3** Click **SetupME.exe** file for ME driver installation.
- 4** Follow the on-screen instructions to complete the installation.
- 5** Once the installation is completed, shut down the system and restart BM-D025 for the changes to take effect.

4.7 Installing Intel® Rapid Storage Utility

The Intel® Rapid Storage Technology option ROM provides the following functions:

- Pre-operating system user interface for RAID volume management
- Ability to create, delete and reset RAID volumes
- RAID recovery

Entering option ROM User Interface from BIOS Setup Utility

Follow the instructions below to enter the Intel® Rapid Storage Technology option ROM user interface:

- 1 Press to access the BIOS Setup Utility program when prompted during the Power-On Self-Test (POST).
- 2 Enter **Chipset > PCH-IO Configuration > SATA Configuration** menu screen and select “**Intel RST With Intel Optane System Acceleration**” option for **SATA Controller(s)** option item. See the pictures below:

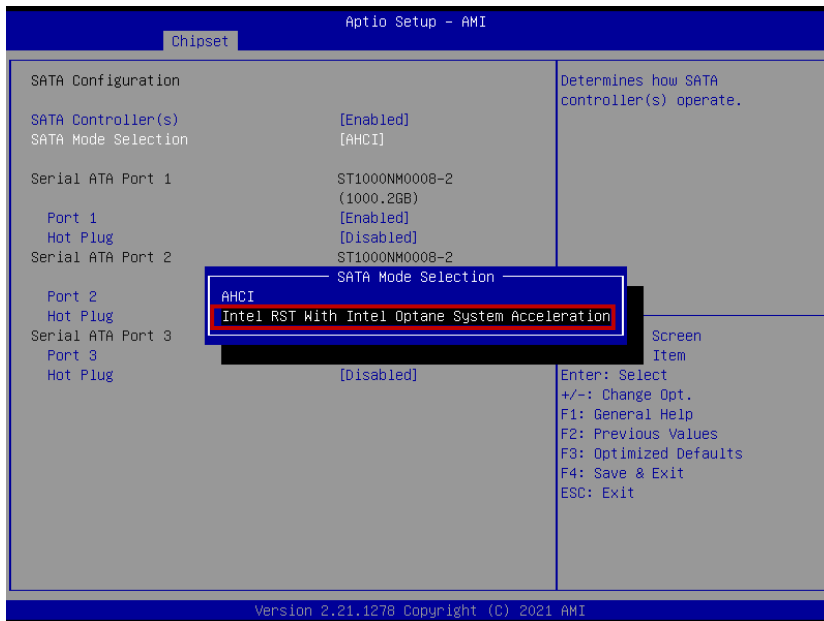

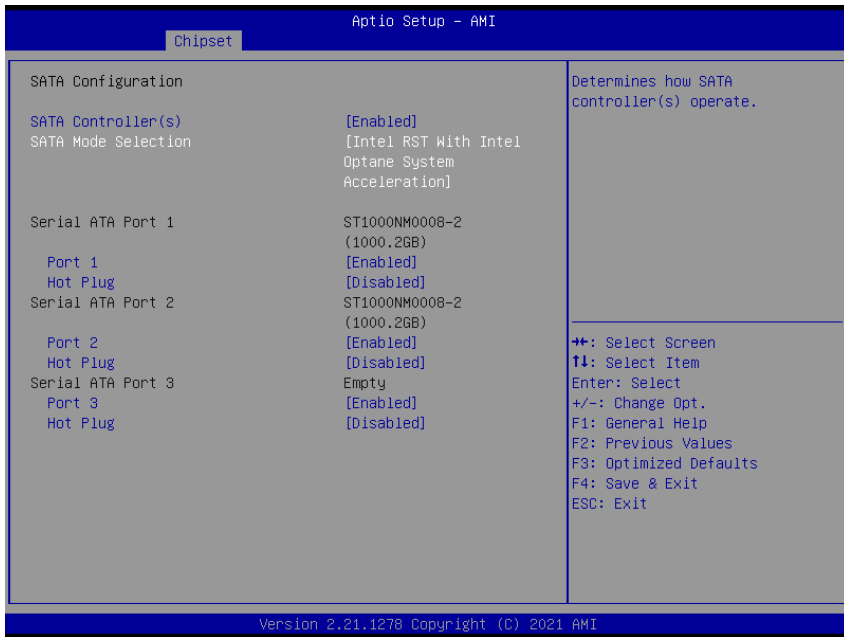

- 3 Press **F4** to save and validate the changed BIOS configuration and reset the system.

- 4 Press to enter the BIOS Setup Utility program again and the **Intel(R) Rapid Storage Technology** option item will display under the **Advanced** menu screen as below:

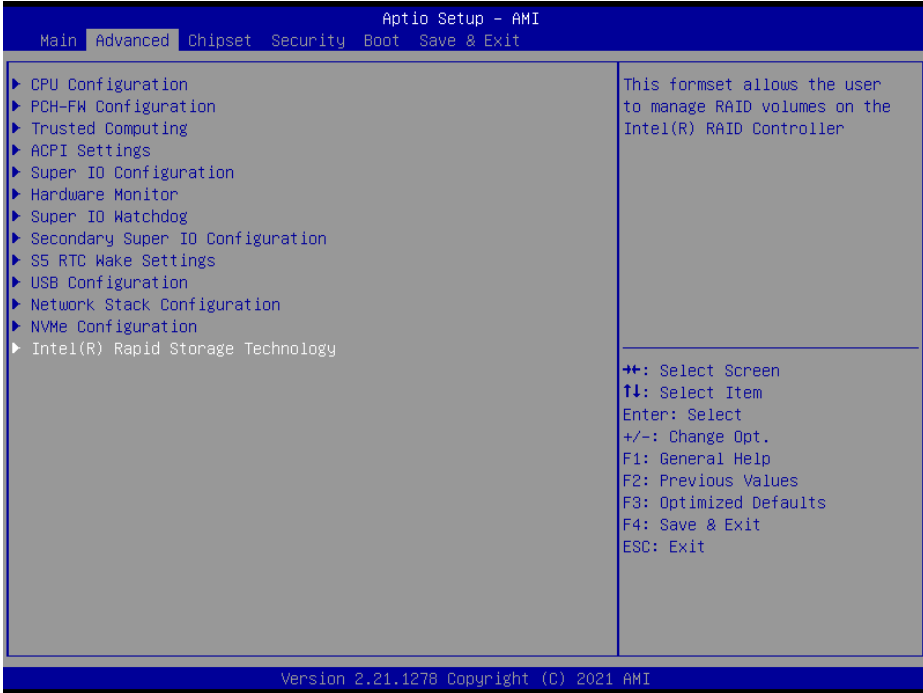

- 5 Select the **Intel(R) Rapid Storage Technology** option item and press **<Enter>**, and the following screen will display. Select a RAID level that you want to enter and press **<Enter>**.

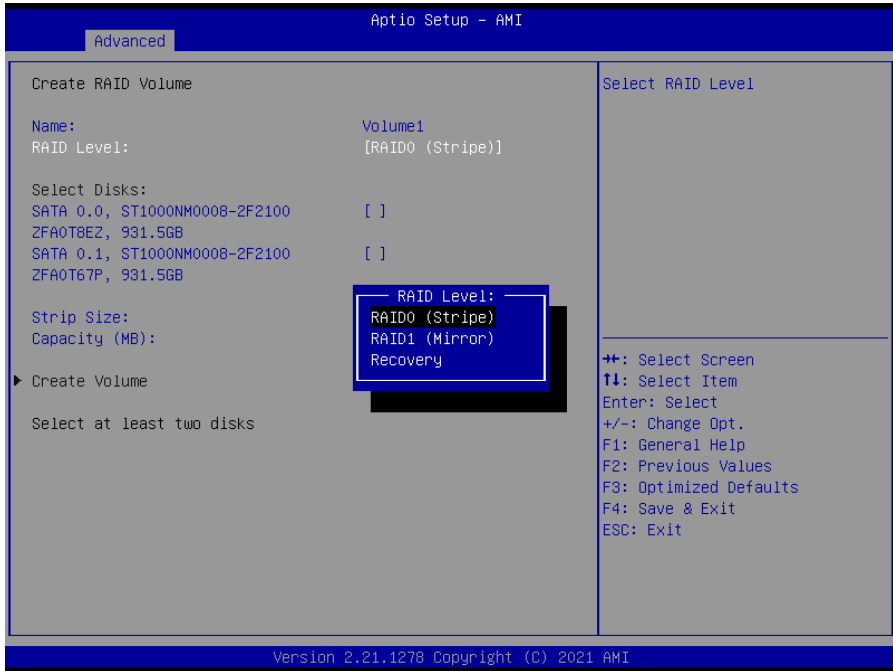

The hard drive(s) and hard drive information of the RAID level you selected in the previous step will display:

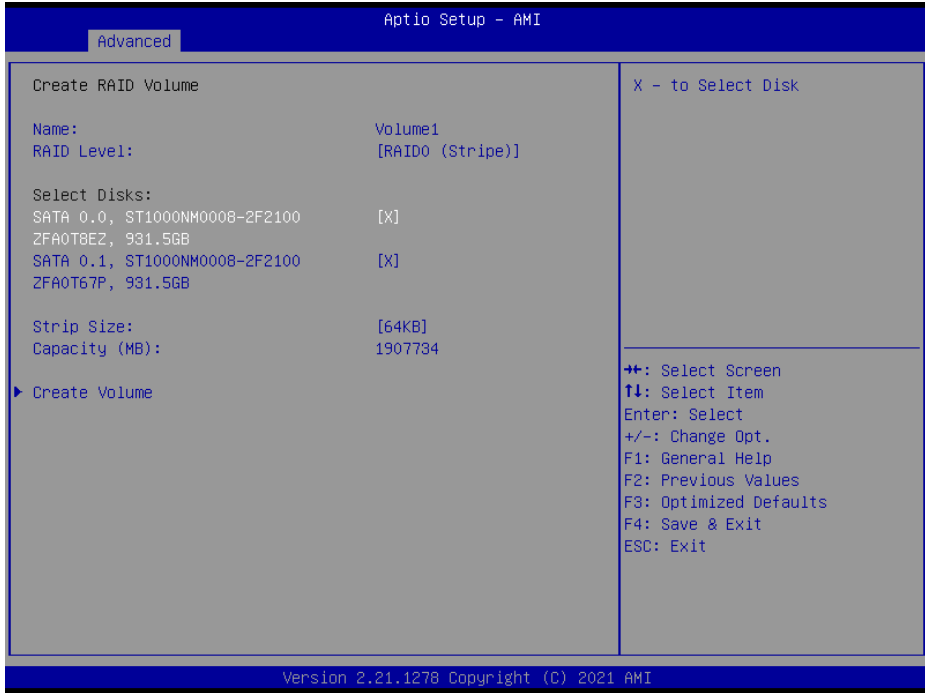

Heed that in the user interface, the hard drive(s) and hard drive information listed for your system will differ from the example above.

6 Create a RAID volume from the picture below as necessary.

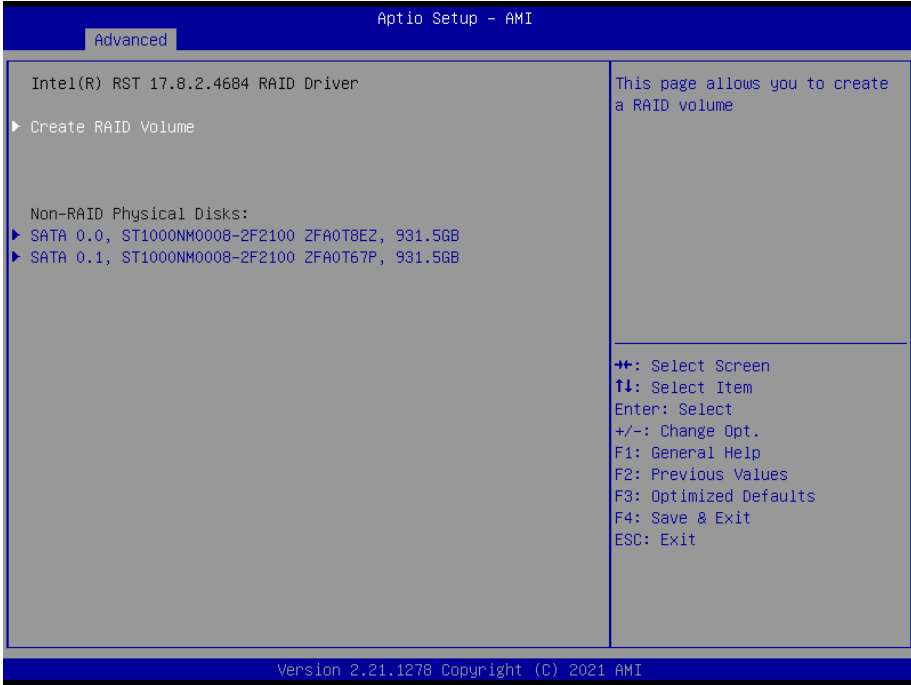

Installing Intel® RST Utility (Only for W480E and Q470E, Optional)

The Intel® Rapid Storage Technology (Intel® RST) utility supports RAID 0, 1 in W480E/Q470E SKU.

To install the RAID utility, follow the steps below:

- 1** Connect the USB DVD-ROM device to BM-D025 and insert the driver disk.
- 2** Enter the **RAID** folder where the utility is located.
- 3** Click **SetupRST.exe** file for utility installation.
- 4** Follow the on-screen instructions to complete the installation.
- 5** Once the installation is completed, shut down the system and restart BM-D025 for the changes to take effect.
- 6** Execute Windows 10 LTSC 2019 update procedure.
The Intel® RST Utility can be activated successfully only after the Windows Update procedure is finished.

Note: The Intel® RST Utility is not supported for H420E SKU.

4.8 Installing Intel® Serial I/O Driver Utility

To install the Serial I/O Driver, follow the steps below:

- 1** Connect the USB DVD-ROM device to BM-D025 and insert the driver disk.
- 2** Open the **Serial IO** folder where the driver is located.
- 3** Click the **SetupSerialIO.exe** file for driver installation.
- 4** Follow the on-screen instructions to complete the installation.
- 5** Once the installation is completed, shut down the system and restart BM-D025 for the changes to take effect.

5 BIOS SETUP

This chapter guides users how to configure the basic system configurations via the BIOS Setup Utilities. The information of the system configuration is saved in BIOS NVRAM so that the Setup information is retained when the system is powered off. The BIOS Setup Utilities consist of the following menu items:

- Main Menu
- Advanced Menu
- Chipset Menu
- Security Menu
- Boot Menu
- Save & Exit Menu

5.1 Introduction

The **BM-D025** board uses an AMI (American Megatrends Incorporated) Aptio BIOS that is stored in the Serial Peripheral Interface Flash Memory (SPI Flash) and can be updated. The SPI Flash contains the built-in BIOS setup program, Power-On Self-Test (POST), PCI auto-configuration utility, LAN EEPROM information, and Plug and Play support.

Aptio is AMI's BIOS firmware based on the UEFI (Unified Extensible Firmware Interface) specifications and the Intel® Platform Innovation Framework for EFI. The UEFI specification defines an interface between the operating system and platform firmware. The interface consists of data tables that contain platform-related information, boot service calls, and runtime service calls that are available to the operating system and its loader. These elements have combined to provide a standard environment for booting the operating system and running pre-boot applications.

The diagram below shows the Extensible Firmware Interface's location in the software stack.

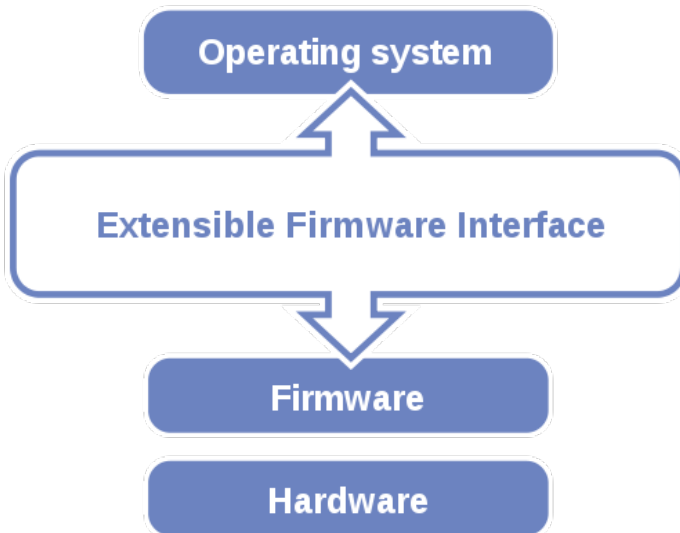

Figure 5-1. Extensible Firmware Interface Diagram

EFI BIOS provides an user interface that allows you to modify hardware configuration, e.g. change the system date and time, enable/disable a system component, determine bootable device priority, set up personal password, etc., which is convenient for engineers to perform modifications and customize the computer system and allows technicians to troubleshoot the occurred errors when the hardware is faulty.

The BIOS setup menu allows users to view and modify the BIOS settings for the computer. After the system is powered on, users can access the BIOS setup menu by pressing or <Esc> immediately while the POST message is running before the operating system is loading.

All the menu settings are described in details in this chapter.

5.2 Accessing Setup Utility

After the system is powered on, BIOS will enter the Power-On Self-Test (POST) routines and the POST message will be displayed:

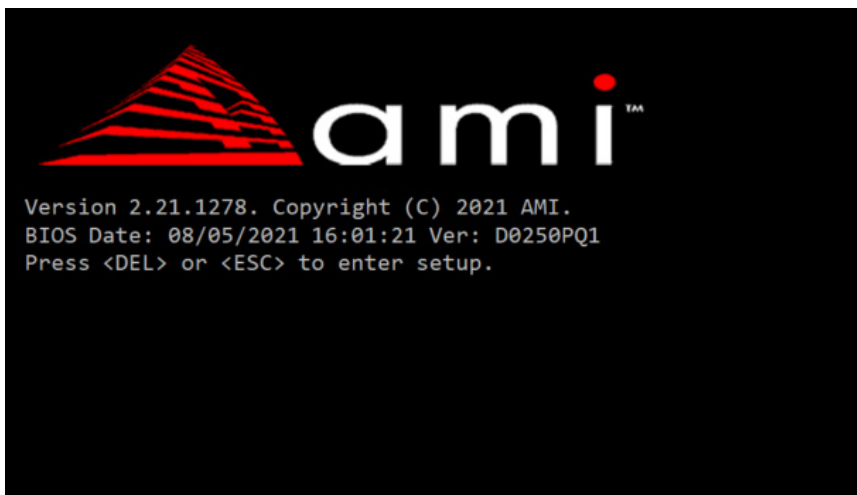

Figure 5-2. POST Screen with AMI Logo

Press or <Esc> to access the Setup Utility program and the **Main** menu of the Aptio Setup Utility will appear on the screen as below:



BIOS Setup Menu Initialization Screen

You may move the cursor by <↑> and <↓> keys to highlight the individual menu items. As you highlight each item, a brief description of the highlighted selection will appear on the right side of the screen.

The language of the BIOS setup menu interface and help messages are shown in US English. You may use <↑> or <↓> key to select among the items and press <Enter> to confirm and enter the sub-menu. The following table provides the list of the navigation keys that you can use while operating the BIOS setup menu.

BIOS Setup Navigation Key	Description
<←> and <→>	Select a different menu screen (move the cursor from the selected menu to the left or right).
<↑> and <↓>	Select a different item (move the cursor from the selected item upwards or downwards)
<Enter>	Execute the command or select the sub-menu.
<F2>	Load the previous configuration values.
<F3>	Load the default configuration values.
<F4>	Save the current values and exit the BIOS setup menu.
<Esc>	Close the sub-menu. Trigger the confirmation to exit BIOS setup menu.

5.3 Main

Menu Path *Main*

The **Main** menu allows you to view the BIOS Information and change the system date and time. Use tab to switch between date elements. Use <↑> or <↓> arrow keys to highlight the item and enter the value you want in each item. This screen also displays the BIOS version (project) and BIOS Build Date and Time.

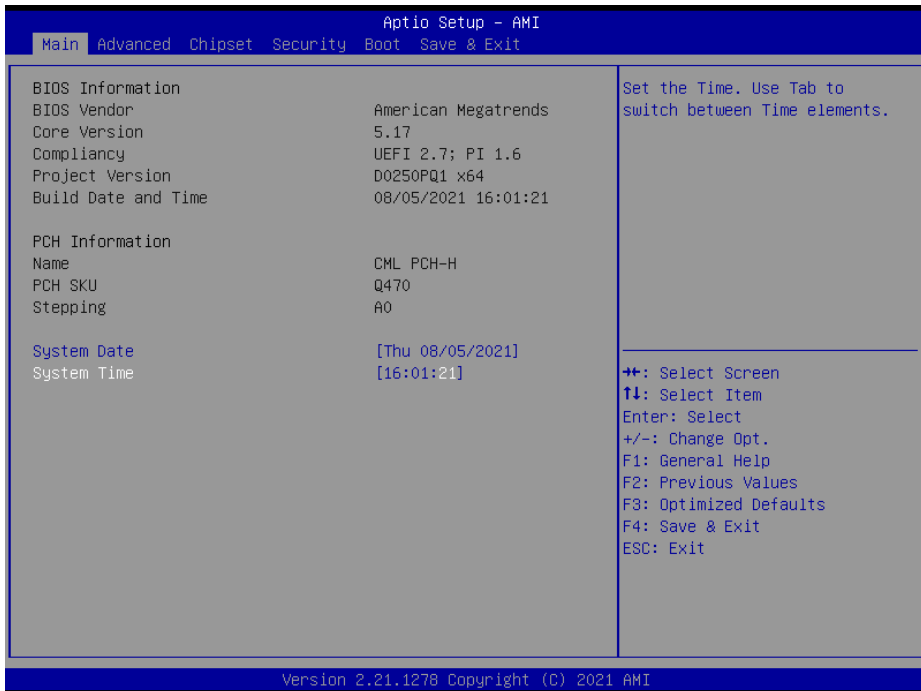

Main Screen

BIOS Setting	Options	Description/Purpose
BIOS Vendor	No changeable options	Displays the BIOS vendor.
Core Version	No changeable options	Displays the current BIOS core version.
Compliancy	No changeable options	Displays the current UEFI version.
Project Version	No changeable options	Displays the version of the BIOS currently installed on the platform.
Build Date and Time	No changeable options	Displays the date of current BIOS version is built.
Name	No changeable options	Displays the name of the PCH.
PCH SKU	No changeable options	Displays the SKU for the PCH.
Stepping	No changeable options	Displays the stepping of the PCH

BIOS Setting	Options	Description/Purpose
System Date	month, day, year	Sets the system date. The format is [Day Month/ Date/ Year]. Users can directly enter values or use <+> or <-> arrow keys to increase/decrease it.
System Time	hour, minute, second	Sets the system time. The format is [Hour: Minute: Second]. Users can directly enter values or use <+> or <-> arrow keys to increase/decrease it.

5.4 Advanced

Menu Path *Advanced*

This menu provides advanced the sub-menu items such as CPU Configuration, PCH-FW Configuration, Trusted Computing, ACPI Settings, Super IO Configuration, Hardware Monitor, Super IO Watchdog, Secondary Super IO Configuration, S5 RTC Wake Settings, USB Configuration, Network Stack Configuration and NVMe Configuration.

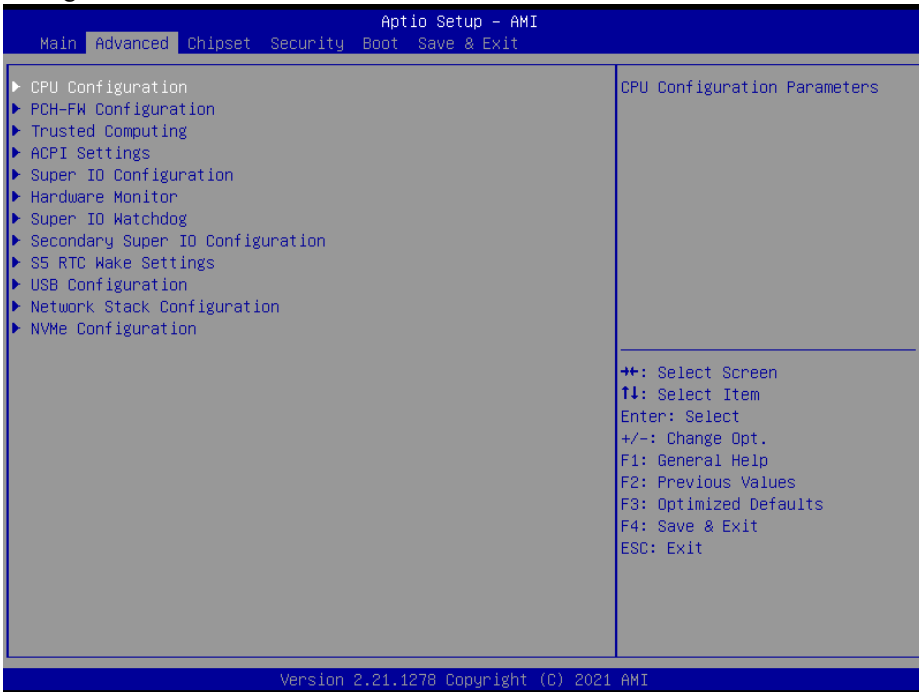

Advanced Menu Screen

BIOS Setting	Options	Description/Purpose
CPU Configuration	Sub-Menu	CPU Configuration Parameters.
PCH-FW Configuration	Sub-Menu	Management Engine Technology Parameters.
Trusted Computing	Sub-Menu	Trusted Computing Settings.
ACPI Settings	Sub-Menu	System ACPI Parameters.
Super IO Configuration	Sub-Menu	System Super I/O Chip Parameters.
Hardware Monitor	Sub-Menu	Monitors hardware status.
Super IO Watchdog	Sub-Menu	Super I/O Watchdog Parameters.
Secondary Super IO Configuration	Sub-Menu	Secondary System Super I/O Chip Parameters.
S5 RTC Wake Settings	Sub-Menu	S5 RTC Wake Parameters.

BIOS Setting	Options	Description/Purpose
USB Configuration	Sub-Menu	USB Configuration Parameters.
Network Stack Configuration	Sub-Menu	Network Stack Settings.
NVMe Configuration	Sub-Menu	NVMe Device Options Settings.

5.4.1 Advanced – CPU Configuration

Menu Path *Advanced > CPU Configuration*

The **CPU Configuration** provides advanced CPU settings and some information about CPU.

CPU Configuration Screen

BIOS Setting	Options	Description/Purpose
Type	No changeable options	Displays the CPU Type.
ID	No changeable options	Displays the CPU ID.
Speed	No changeable options	Displays the CPU Speed.
L1 Data Cache	No changeable options	L1 Data Cache Size.
L1 Instruction Cache	No changeable options	L1 Instruction Cache Size.
L2 Cache	No changeable options	L2 Cache Size.
L3 Cache	No changeable options	L3 Cache Size.

BIOS Setting	Options	Description/Purpose
VMX	No changeable options	CPU VMX hardware support for virtual machines.
SMX (Secure Mode Extensions) / TXT	No changeable options	Secure Mode extensions support.
Intel® Virtualization Technology	- Disabled - Enabled (default)	When enabled, VMM can utilize the additional hardware capabilities provided by Vanderpool Technology.
Hyper-Threading	- Disabled - Enabled (default)	When Disabled, only one thread per enabled core is enabled.

5.4.2 Advanced – PCH-FW Configuration

Menu Path *Advanced > PCH-FW Configuration*

The **PCH-FW** allows users to view the information about ME (Management Engine) firmware information, such as ME firmware version, firmware mode and firmware SKU.

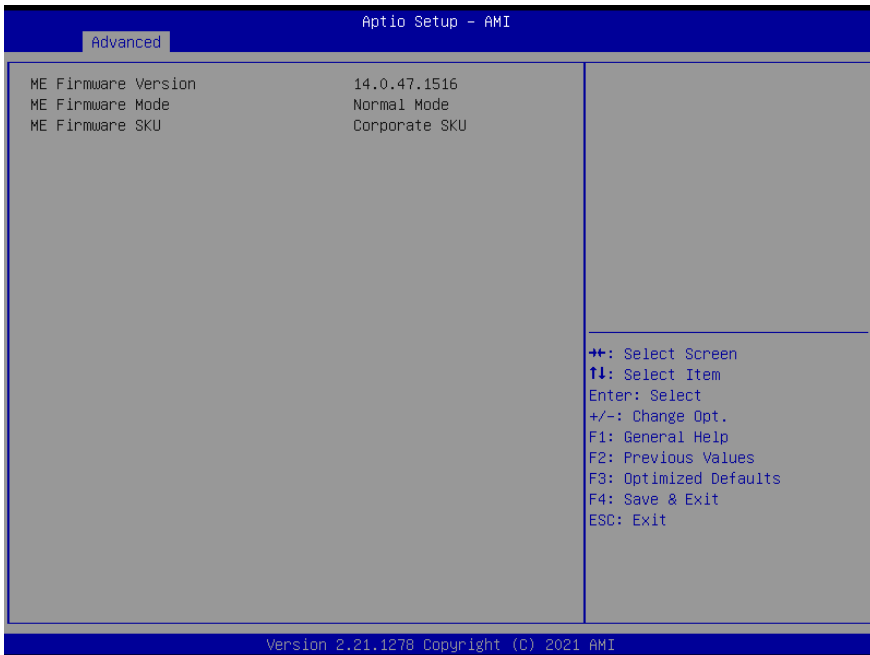

PCH-FW Configuration Screen

BIOS Setting	Options	Description/Purpose
ME Firmware Version	No changeable options	Displays the ME Firmware Version.
ME Firmware Mode	No changeable options	Displays the ME Firmware Mode.
ME Firmware SKU	No changeable options	Displays the ME Firmware SKU.

5.4.3 Advanced – Trusted Computing

Menu Path *Advanced > Trusted Computing*

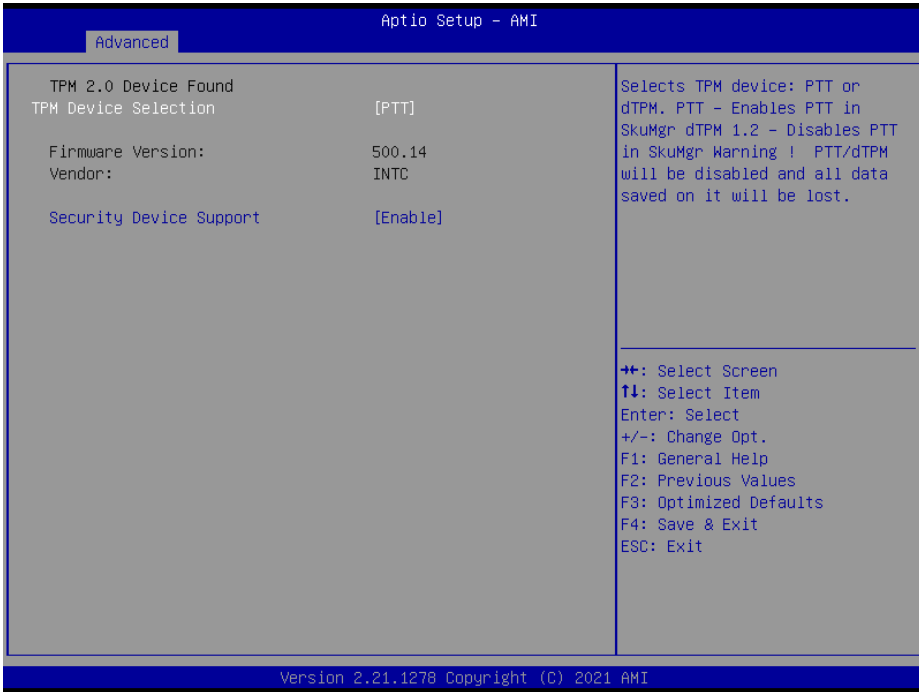

Trusted Computing Screen

BIOS Setting	Options	Description/Purpose
TPM Device Selection	- dTPM - PTT (Default)	Selects TPM device: PTT or dTPM. PTT - Enables PTT in SkuMgr dTPM 1.2 - Disables PTT in SkuMgr Warning ! PTT/dTPM will be disabled and all data saved on it will be lost.
Firmware Version:	No changeable options	TPM firmware version.
Vendor:	No changeable options	TPM module vendor.
Security Device Support	- Enable (Default) - Disable	Enables or Disables BIOS support for security device. O.S. will not show Security Device. TCG EFI protocol and INT1A interface will not be available.

5.4.4 Advanced – ACPI Settings

Menu Path *Advanced > ACPI Settings*

The **ACPI Settings** allows users to configure relevant ACPI (Advanced Configuration and Power Management Interface) settings, such as enable/disable ACPI Auto Configuration, Hibernation, ACPI Sleep State and S3 Video Repost.

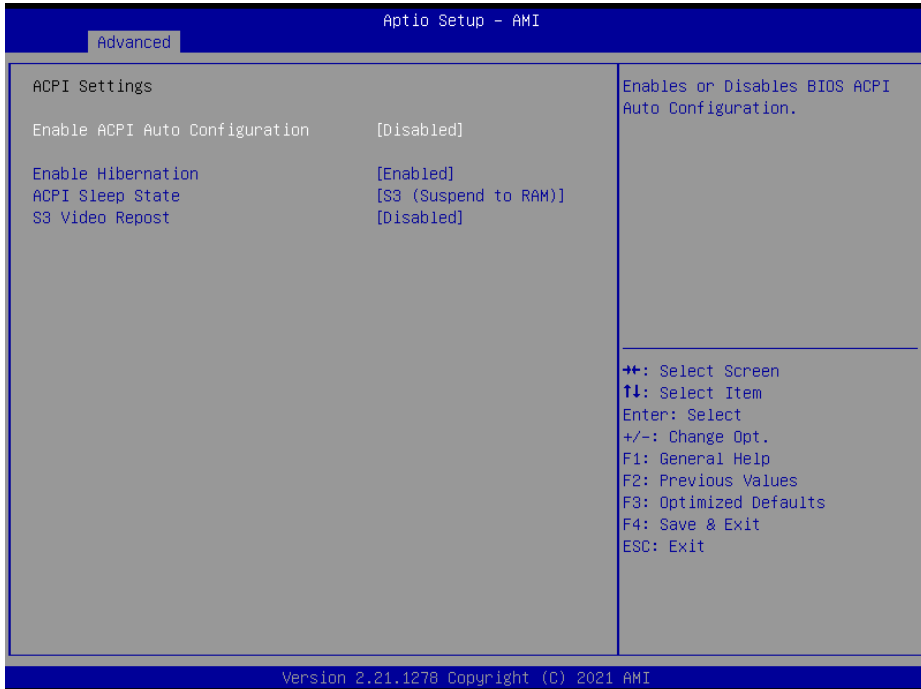

ACPI Settings Screen

BIOS Setting	Options	Description/Purpose
Enable ACPI Auto Configuration	- Disabled (Default) - Enabled	Enables or Disables BIOS ACPI Auto Configuration.
Enable Hibernation	- Disabled - Enabled (Default)	Enables or Disables System ability to Hibernate (OS/S4 Sleep State). This option may be not effective with some OS.
ACPI Sleep State	- Suspend Disabled - S3 (Suspend to RAM) (Default)	Selects the highest ACPI sleep state the system will enter when the SUSPEND button is pressed.
S3 Video Repost	- Disabled (Default) - Enabled	Enables or Disables S3 Video Repost.

5.4.5 Advanced – Super IO Configuration

Menu Path *Advanced > Super IO Configuration*

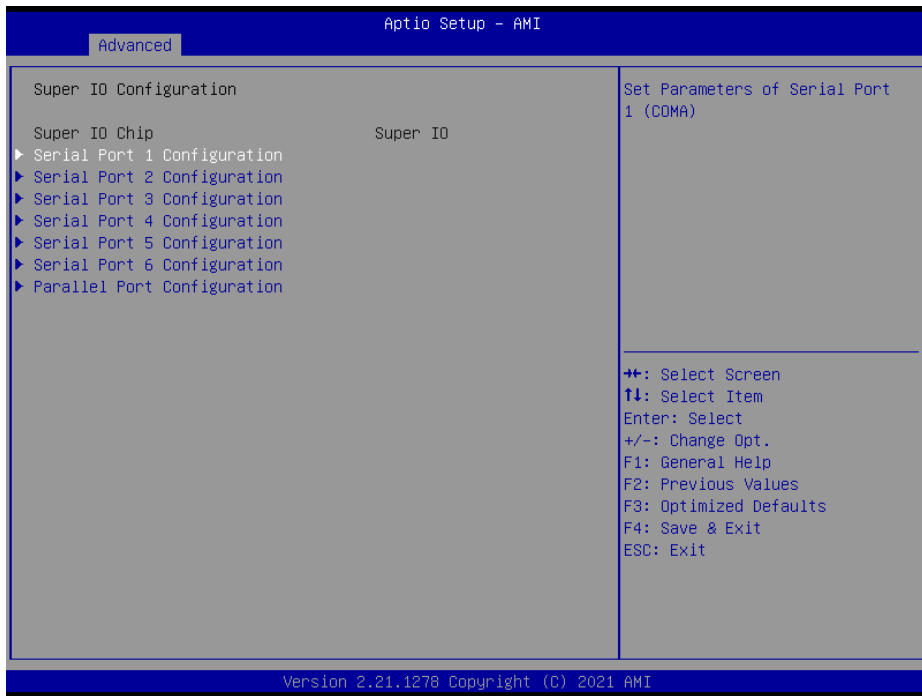

Super IO Configuration Screen

BIOS Setting	Options	Description/Purpose
Serial Port 1 Configuration	Sub-Menu	Sets Parameters of Serial Port 1 (COM1).
Serial Port 2 Configuration	Sub-Menu	Sets Parameters of Serial Port 2 (COM2).
Serial Port 3 Configuration	Sub-Menu	Sets Parameters of Serial Port 3 (COM3).
Serial Port 4 Configuration	Sub-Menu	Sets Parameters of Serial Port 4 (COM4).
Serial Port 5 Configuration	Sub-Menu	Sets Parameters of Serial Port 5 (COM5).
Serial Port 6 Configuration	Sub-Menu	Sets Parameters of Serial Port 6 (COM6).
Parallel Port Configuration	Sub-Menu	Sets Parameters of Parallel Port (LPT/LPTE).

Super IO Configuration – Serial Port 1 Configuration

Menu Path *Advanced > Super IO Configuration > Serial Port 1 Configuration*

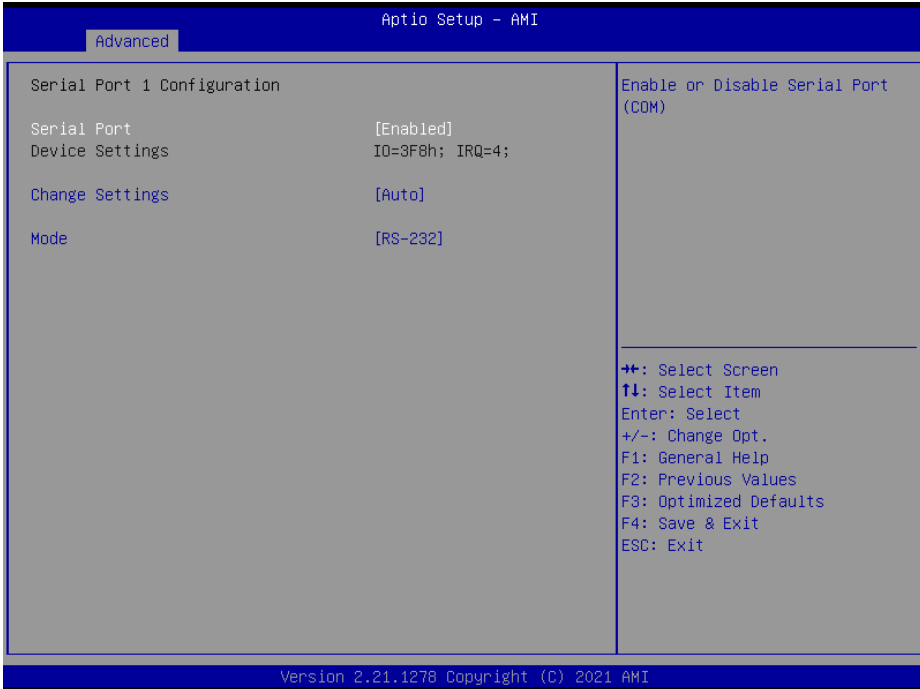

Serial Port 1 Configuration Screen

BIOS Setting	Options	Description/Purpose
Serial Port	- Disabled - Enabled (Default)	Enables or Disables Serial Port 1.
Device Settings	No changeable options	Displays current settings of Serial Port 1.
Change Settings	- Auto (default) - IO=3F8h; IRQ=4; - IO=3F8h; IRQ=3,4,5,6,7,9,10,11,12; - IO=2F8h; IRQ=3,4,5,6,7,9,10,11,12; - IO=3E8h; IRQ=3,4,5,6,7,9,10,11,12; - IO=2E8h; IRQ=3,4,5,6,7,9,10,11,12;	Selects IRQ and I/O resource for Serial Port 1.
Mode	- RS-232 (Default) - RS-422 - RS-485	Selects COM mode.

Super IO Configuration – Serial Port 2 Configuration

Menu Path *Advanced > Super IO Configuration > Serial Port 2 Configuration*

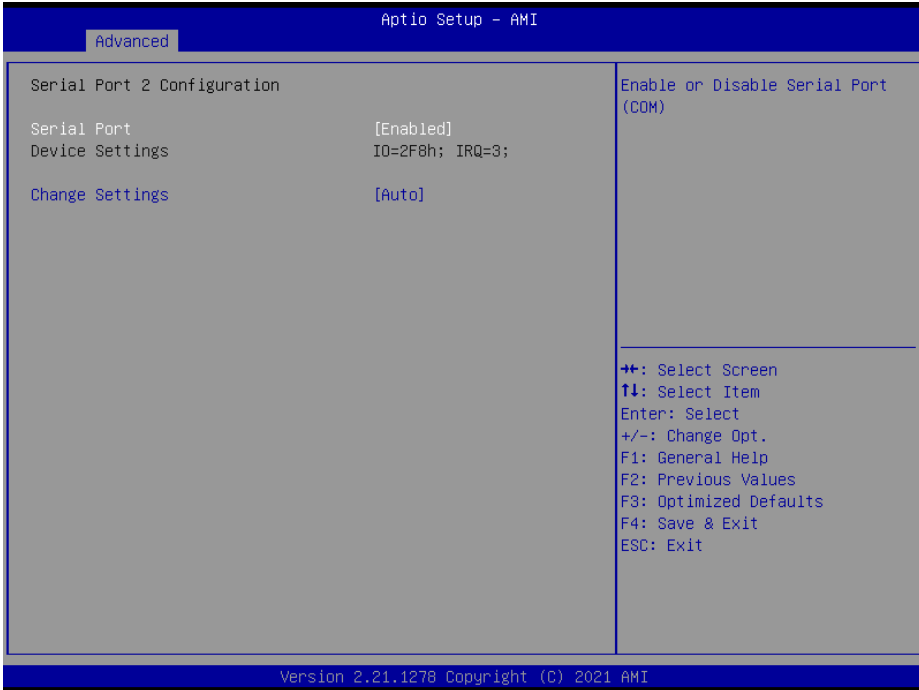

Serial Port 2 Configuration Screen

BIOS Setting	Options	Description/Purpose
Serial Port	- Disabled - Enabled (Default)	Enables or Disables Serial Port 2.
Device Settings	No changeable options	Displays current settings of Serial Port 2.
Change Settings	- Auto (default) - IO=2F8h; IRQ=3; - IO=3F8h; IRQ=3,4,5,6,7,9,10,11,12; - IO=2F8h; IRQ=3,4,5,6,7,9,10,11,12; - IO=3E8h; IRQ=3,4,5,6,7,9,10,11,12; - IO=2E8h; IRQ=3,4,5,6,7,9,10,11,12;	Selects IRQ and I/O resource for the Serial Port 2.

Super IO Configuration – Serial Port 3 Configuration

Menu Path *Advanced > Super IO Configuration > Serial Port 3 Configuration*

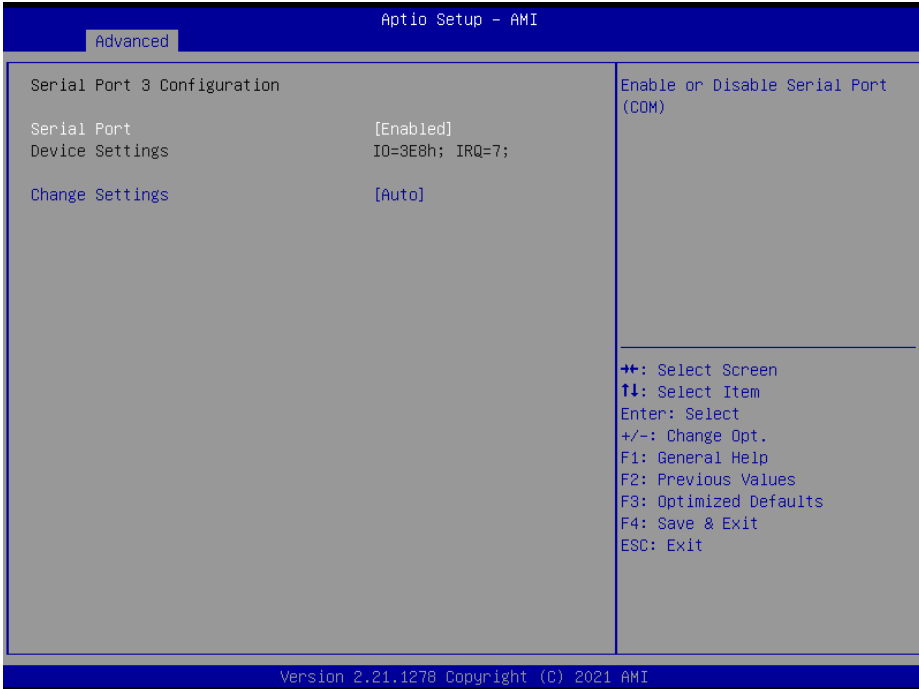

Serial Port 3 Configuration Screen

BIOS Setting	Options	Description/Purpose
Serial Port	- Disabled - Enabled (Default)	Enables or Disables Serial Port 3.
Device Settings	No changeable options	Displays current settings of Serial Port 3.
Change Settings	- Auto (default) - IO=3E8h; IRQ=7; - IO=3E8h; IRQ=3,4,5,6,7,9,10,11,12; - IO=2E8h; IRQ=3,4,5,6,7,9,10,11,12; - IO=2F0h; IRQ=3,4,5,6,7,9,10,11,12; - IO=2E0h; IRQ=3,4,5,6,7,9,10,11,12;	Selects IRQ and I/O resource for Serial Port 3.

Super IO Configuration – Serial Port 4 Configuration

Menu Path *Advanced > Super IO Configuration > Serial Port 4 Configuration*

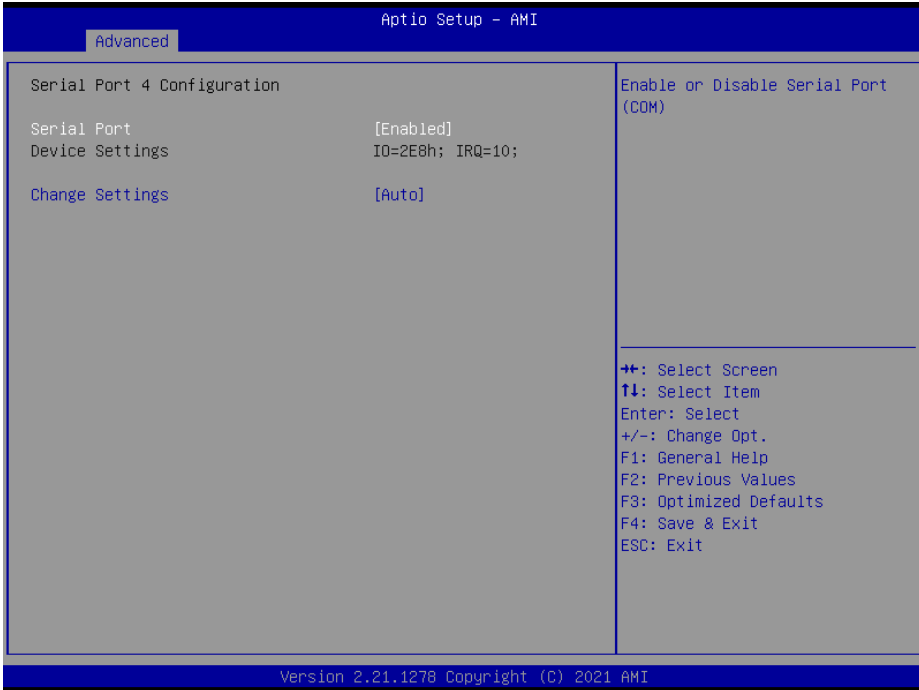

Serial Port 4 Configuration Screen

BIOS Setting	Options	Description/Purpose
Serial Port	- Disabled - Enabled (Default)	Enables or Disables Serial Port 4.
Device Settings	No changeable options	Displays current settings of Serial Port 4.
Change Settings	- Auto (default) - IO=2E8h; IRQ=10; - IO=3E8h; IRQ=3,4,5,6,7,9,10,11,12; - IO=2E8h; IRQ=3,4,5,6,7,9,10,11,12; - IO=2F0h; IRQ=3,4,5,6,7,9,10,11,12; - IO=2E0h; IRQ=3,4,5,6,7,9,10,11,12;	Selects IRQ and I/O resource for the Serial Port 4.

Super IO Configuration – Serial Port 5 Configuration

Menu Path *Advanced > Super IO Configuration > Serial Port 5 Configuration*

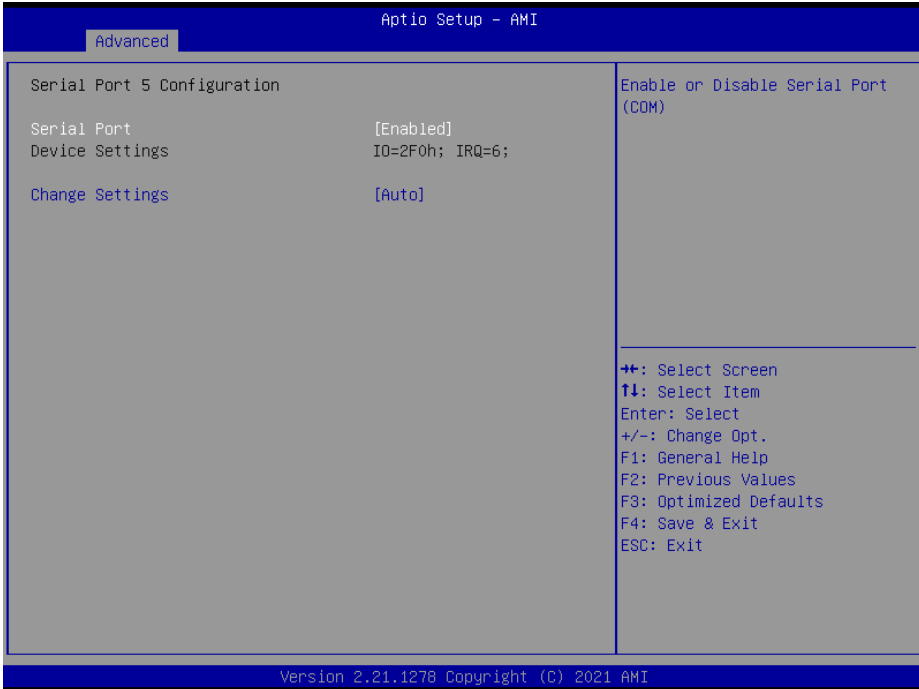

Serial Port 5 Configuration Screen

BIOS Setting	Options	Description/Purpose
Serial Port	- Disabled - Enabled (Default)	Enables or Disables Serial Port 5.
Device Settings	No changeable options	Displays current settings of Serial Port 5.
Change Settings	- Auto (default) - IO=2F0h; IRQ=6; - IO=3E8h; IRQ=3,4,5,6,7,9,10,11,12; - IO=2E8h; IRQ=3,4,5,6,7,9,10,11,12; - IO=2F0h; IRQ=3,4,5,6,7,9,10,11,12; - IO=2E0h; IRQ=3,4,5,6,7,9,10,11,12;	Selects IRQ and I/O resource for the Serial Port 5.

Super IO Configuration – Serial Port 6 Configuration

Menu Path *Advanced > Super IO Configuration > Serial Port 6 Configuration*

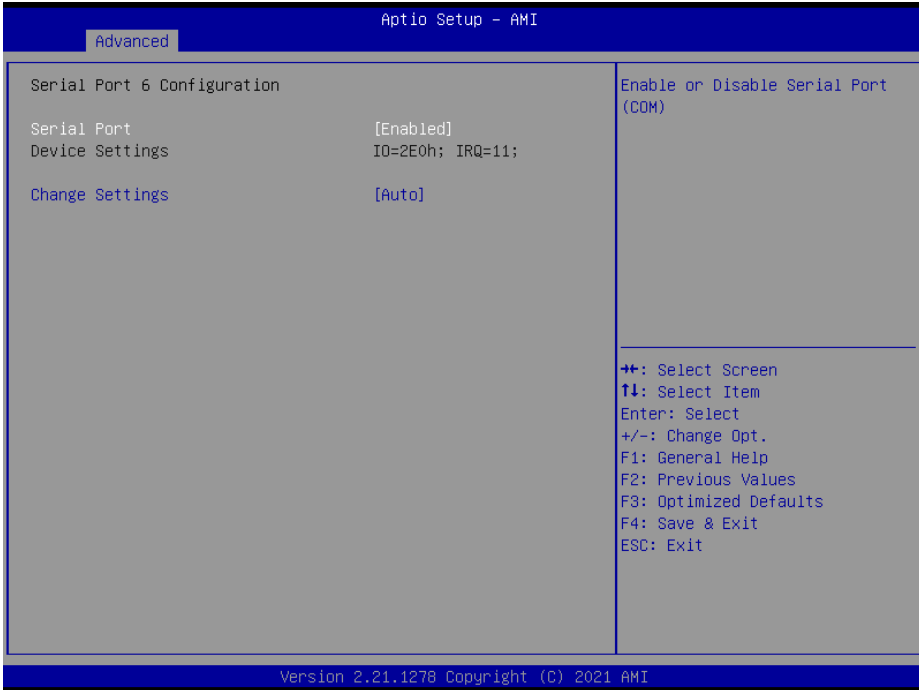

Serial Port 6 Configuration Screen

BIOS Setting	Options	Description/Purpose
Serial Port	- Disabled - Enabled (Default)	Enables or Disables Serial Port 6.
Device Settings	No changeable options	Displays current settings of Serial Port 6.
Change Settings	- Auto (default) - IO=2E0h; IRQ=11; - IO=3E8h; IRQ=3,4,5,6,7,9,10,11,12; - IO=2E8h; IRQ=3,4,5,6,7,9,10,11,12; - IO=2F0h; IRQ=3,4,5,6,7,9,10,11,12; - IO=2E0h; IRQ=3,4,5,6,7,9,10,11,12;	Selects IRQ and I/O resource for the Serial Port 6.

Super IO Configuration – Parallel Port Configuration

Menu Path *Advanced > Super IO Configuration > Parallel Port Configuration*

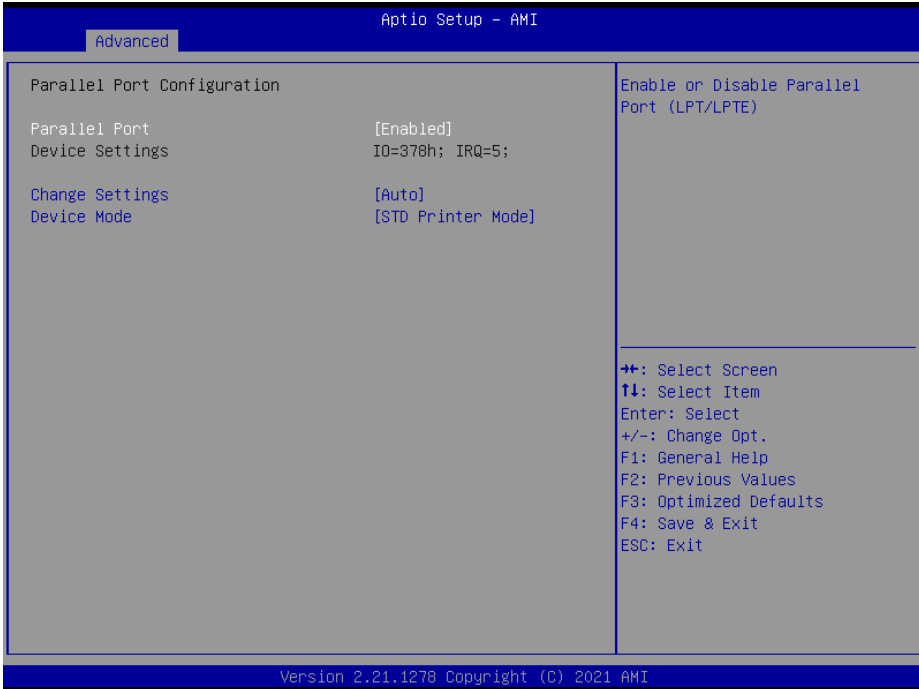

Parallel Port Configuration Screen

BIOS Setting	Options	Description/Purpose
Parallel Port	- Disabled - Enabled (Default)	Enables or Disables Parallel Port (LPT/LPTE).
Device Settings	No changeable options	Displays current settings of Parallel Port.
Change Settings	- Auto (Default) - IO=378h; IRQ=5; - IO=378h; IRQ=5,6,7,9,10,11,12; - IO=278h; IRQ=5,6,7,9,10,11,12; - IO=3BCh; IRQ=5,6,7,9,10,11,12;	Selects IRQ and I/O resource for the Parallel Port,
Device Mode	- STD Printer Mode (Default) - SPP Mode; - EPP-1.9 and SPP Mode; - EPP-1.7 and SPP Mode; - ECP Mode; - ECP and EPP 1.9 Mode; - ECP and EPP 1.7 Mode;	Changes the Printer Port mode.

5.4.6 Advanced – Hardware Monitor

Menu Path *Advanced > Hardware Monitor*

The **Hardware Monitor** allows users to configure Smart Fan Mode for CPU fan, monitor the health and status of the system such as CPU temperature, system temperature, system and CPU fan speed and voltage levels in supply.



Hardware Monitor Screen

BIOS Setting	Options	Description/Purpose
Smart Fan Mode Configuration	Sub-Menu	Smart Fan Mode Selection.
CPU Temperature	No changeable options	Displays processor's temperature.
System Temperature	No changeable options	Displays system's temperature.
CPU Fan Speed	No changeable options	Display CPU Fan speed
System Fan Speed	No changeable options	Display System Fan speed
VCORE	No changeable options	Displays the voltage level of VCORE in supply.
VCC5V	No changeable options	Displays the voltage level of VCC5V in supply.
VCC12	No changeable options	Displays the voltage level of VCC12 in supply.

BIOS Setting	Options	Description/Purpose
VSB5V	No changeable options	Displays the voltage level of VSB5V in supply.

Smart Fan Mode Configuration

Menu Path *Advanced > Hardware Monitor > Smart Fan Mode Configuration*

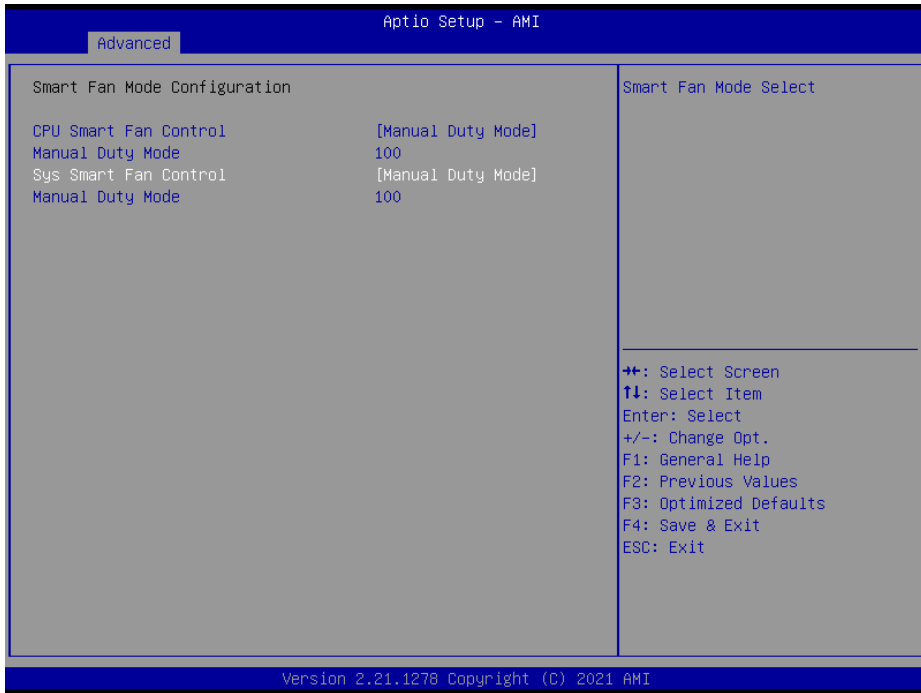

Smart Fan Mode Configuration Screen

BIOS Setting	Options	Description/Purpose
CPU Smart Fan Control	- Manual Duty Mode - Auto Duty-Cycle Mode (Default)	Smart Fan Mode selection for CPU Fan.
Manual Duty Mode	Numeric (from 1 to 100)	Manual mode fan control. Users can write expected duty cycle (PWM fan type) 1-100.
Sys Smart Fan Control	- Manual Duty Mode - Auto Duty-Cycle Mode (Default)	Smart Fan Mode selection for System Fan.
Manual Duty Mode	Numeric (from 1 to 100)	Manual mode fan control. Users can write expected duty cycle (PWM fan type) 1-100.

5.4.7 Advanced – Super IO Watchdog

Menu Path *Advanced > Super IO Watchdog*

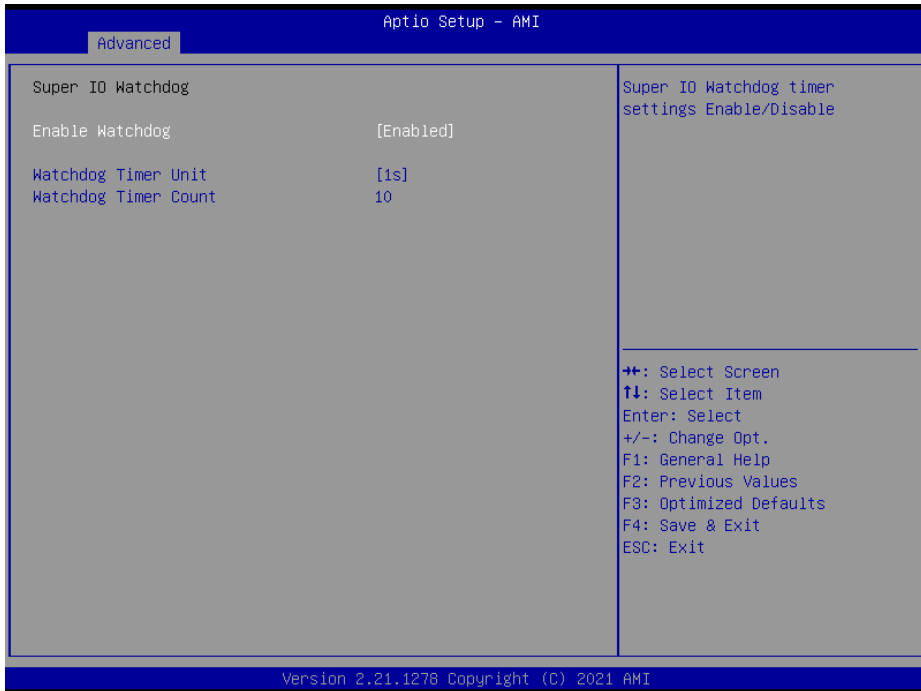

Super IO Watchdog Screen

BIOS Setting	Options	Description/Purpose
Enable Watchdog	- Enabled - Disabled (Default)	Super I/O Watchdog timer settings enabled/disabled.
Watchdog Timer Unit	- 1s (Default) - 60s	Selects time unit (1sec/ 60sec) of watchdog timer.
Watchdog Timer Count	Numeric	The number of second count for Timer (10-59 seconds).

5.4.8 Advanced – Secondary Super IO Configuration

Menu Path *Advanced > Secondary Super IO Configuration*

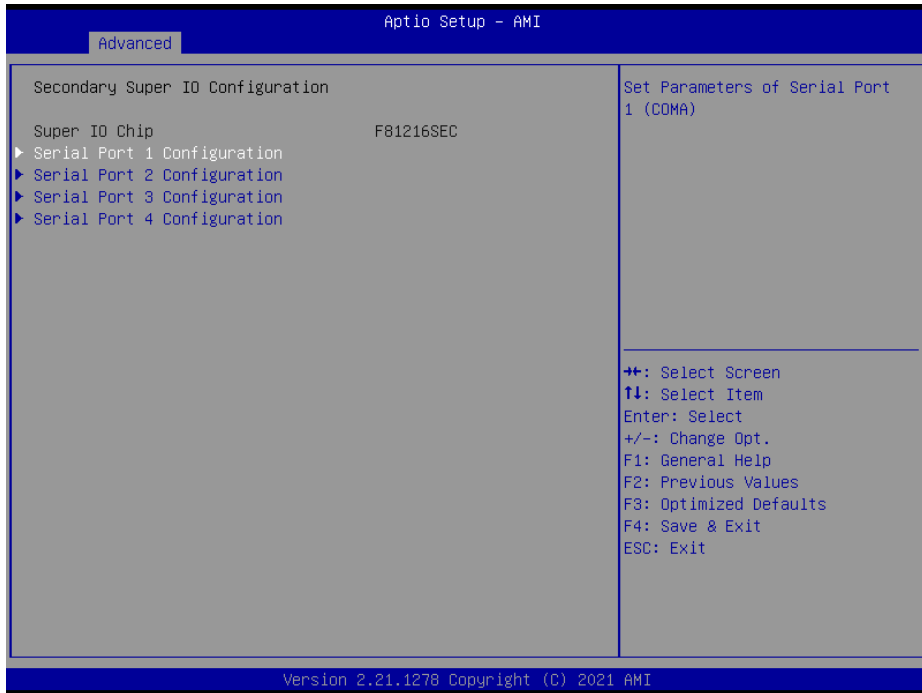

Secondary Super IO Configuration Screen

BIOS Setting	Options	Description/Purpose
Super IO Chip	No changeable options	F81216SEC
Serial Port 1 Configuration	Sub-Menu	Set Parameters of Serial Port 1 (COM1)
Serial Port 2 Configuration	Sub-Menu	Set Parameters of Serial Port 2 (COM2)
Serial Port 3 Configuration	Sub-Menu	Set Parameters of Serial Port 3 (COM3)
Serial Port 4 Configuration	Sub-Menu	Set Parameters of Serial Port 4 (COM4)

Advanced – Secondary Super IO Configuration – Serial Port 1 Configuration

Menu Path *Advanced > Secondary Super IO Configuration > Serial Port 1 Configuration*



Serial Port 1 Configuration (Secondary Super IO Configuration)

BIOS Setting	Options	Description/Purpose
Serial Port	- Disabled - Enabled (Default)	Enables or Disables Serial Port 1.
Device Settings	No changeable options	Displays current settings of Serial Port 1.
Change Settings	- Auto (default) - IO=240h; IRQ=12; - IO=240h; IRQ=3,4,5,6,7,9,10,11,12; - IO=248h; IRQ=3,4,5,6,7,9,10,11,12; - IO=250h; IRQ=3,4,5,6,7,9,10,11,12; - IO=258h; IRQ=3,4,5,6,7,9,10,11,12;	Selects IRQ and I/O resource for the Serial Port 1.

Advanced – Secondary Super IO Configuration – Serial Port 2 Configuration

Menu Path *Advanced > Secondary Super IO Configuration > Serial Port 2 Configuration*

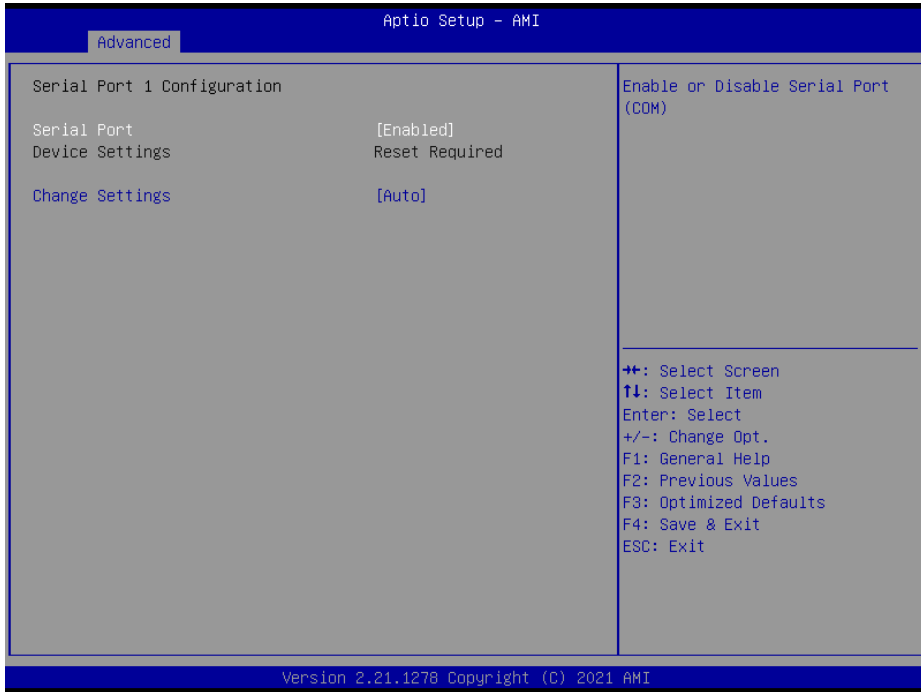

Serial Port 2 Configuration (Secondary Super IO Configuration)

BIOS Setting	Options	Description/Purpose
Serial Port	- Disabled - Enabled (Default)	Enables or Disables Serial Port 2.
Device Settings	No changeable options	Displays current settings of Serial Port 2.
Change Settings	- Auto (default) - IO=248h; IRQ=12; - IO=240h; IRQ=3,4,5,6,7,9,10,11,12; - IO=248h; IRQ=3,4,5,6,7,9,10,11,12; - IO=250h; IRQ=3,4,5,6,7,9,10,11,12; - IO=258h; IRQ=3,4,5,6,7,9,10,11,12;	Selects IRQ and I/O resource for the Serial Port 2.

Advanced – Secondary Super IO Configuration – Serial Port 3 Configuration

Menu Path *Advanced > Secondary Super IO Configuration > Serial Port 3 Configuration*

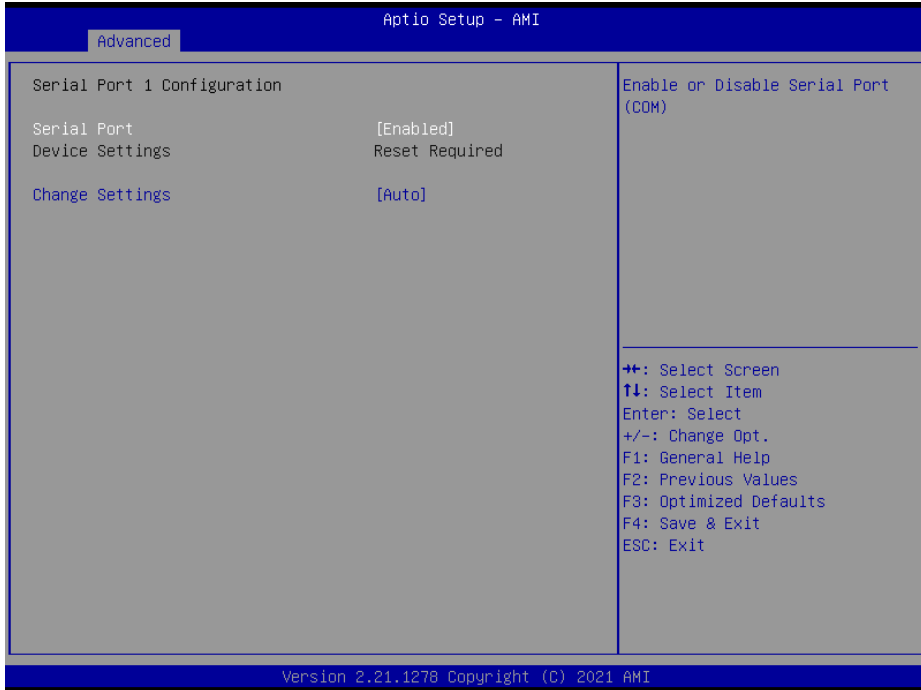

Serial Port 3 Configuration (Secondary Super IO Configuration)

BIOS Setting	Options	Description/Purpose
Serial Port	- Disabled - Enabled (Default)	Enables or Disables Serial Port 3.
Device Settings	No changeable options	Displays current settings of Serial Port 3.
Change Settings	- Auto (default) - IO=250h; IRQ=12; - IO=240h; IRQ=3,4,5,6,7,9,10,11,12; - IO=248h; IRQ=3,4,5,6,7,9,10,11,12; - IO=250h; IRQ=3,4,5,6,7,9,10,11,12; - IO=258h; IRQ=3,4,5,6,7,9,10,11,12;	Selects IRQ and I/O resource for the Serial Port 3.

Advanced – Secondary Super IO Configuration – Serial Port 4 Configuration

Menu Path *Advanced > Secondary Super IO Configuration > Serial Port 4 Configuration*



Serial Port 4 Configuration (Secondary Super IO Configuration)

BIOS Setting	Options	Description/Purpose
Serial Port	- Disabled - Enabled (Default)	Enables or Disables Serial Port 4.
Device Settings	No changeable options	Displays current settings of Serial Port 4.
Change Settings	- Auto (default) - IO=258h; IRQ=12; - IO=240h; IRQ=3,4,5,6,7,9,10,11,12; - IO=248h; IRQ=3,4,5,6,7,9,10,11,12; - IO=250h; IRQ=3,4,5,6,7,9,10,11,12; - IO=258h; IRQ=3,4,5,6,7,9,10,11,12;	Selects IRQ and I/O resource for the Serial Port 4.

5.4.9 Advanced – S5 RTC Wake Settings [Fixed Time]

Menu Path *Advanced > S5 RTC Wake Settings[Fixed Time]*

The **S5 RTC Wake Settings** enables/disables the system to wake up at a preset time of a day from S5 State using RTC alarm.



S5 RTC Wake Settings Screen[Fixed Time]

BIOS Setting	Options	Description/Purpose
Wake system from S5	<ul style="list-style-type: none"> - Disabled (Default) - Fixed Time - Dynamic Time 	<p>Enables or disables System to wake on alarm events.</p> <ul style="list-style-type: none"> • Fixed Time: The system will wake on the time (hr::min::sec) specified. • Dynamic Time: The system will wake on the current time + Increase minute(s).
Wake up hour	Numeric (from 0 to 23)	Enters 0-23 to set the wake-up hour, e.g.: enters 3 for 3 a.m. and 15 for 3 pm
Wake up minute	Numeric (from 0 to 59)	Enters 0-59 to set the wake-up minute.
Wake up second	Numeric (from 0 to 59)	Enters 0-59 to set the wake-up second.

Advanced – S5 RTC Wake Settings [Dynamic Time]

Menu Path *Advanced > S5 RTC Wake Settings[Dynamic Time]*

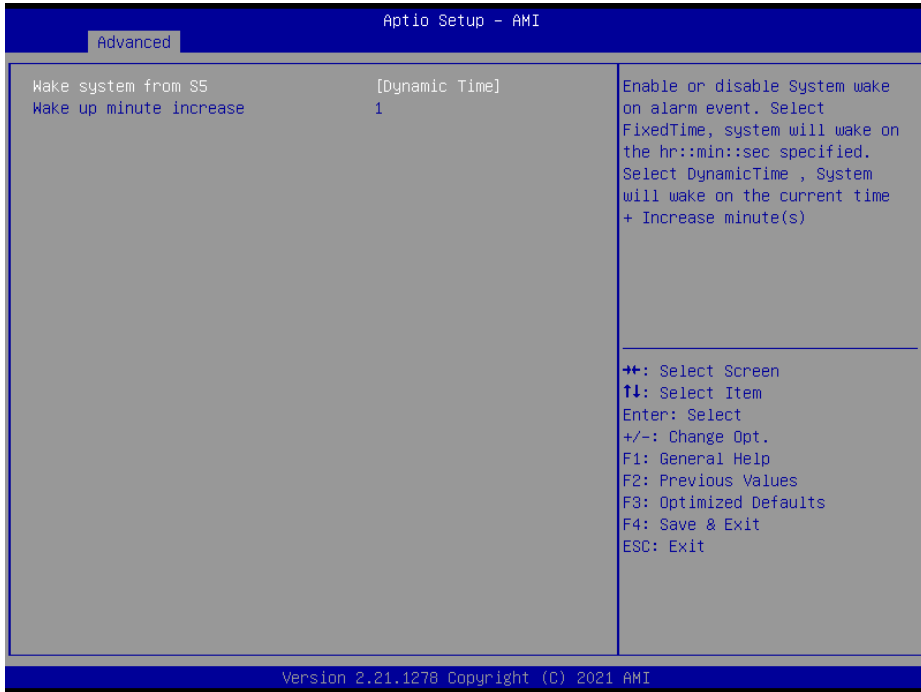

S5 RTC Wake Settings Screen[Dynamic Time]

BIOS Setting	Options	Description/Purpose
Wake system from S5	- Disabled (Default) - Fixed Time - Dynamic Time	Enables or disables System to wake on alarm events. <ul style="list-style-type: none"> • Fixed Time: The system will wake on the time (hr::min::sec) specified. • Dynamic Time: The system will wake on the current time + Increase minute(s).
Wake up minute increase	Numeric (from 1 to 5)	Enters 1-5 to set the increased minute(s) for dynamic wake-up time.

5.4.10 Advanced – USB Configuration

Menu Path *Advanced > USB Configuration*

The **USB Configuration** allows users to configure advanced USB settings such as USB mass storage driver support.

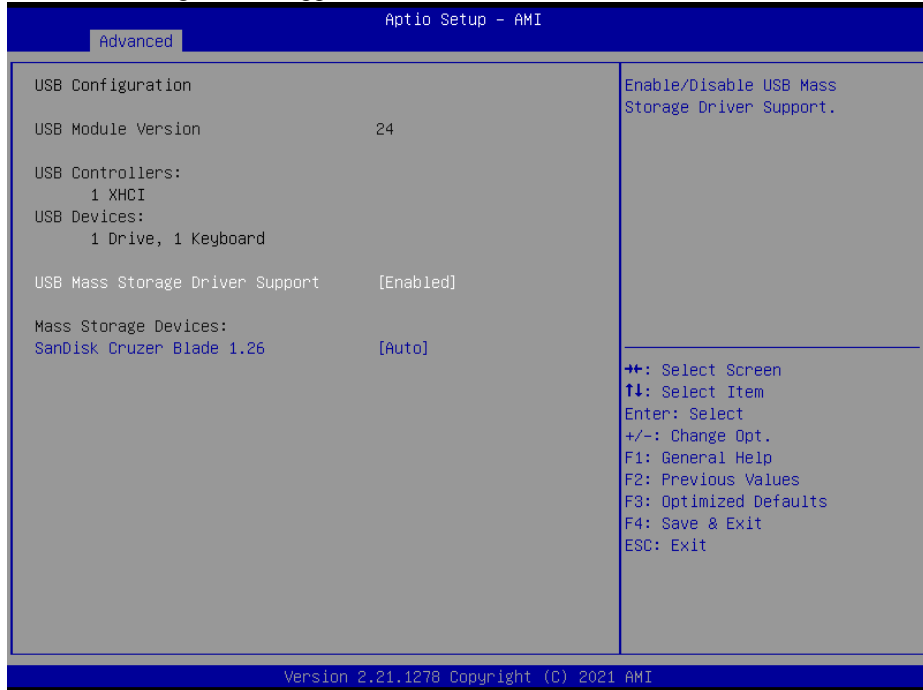

USB Configuration Screen

BIOS Setting	Options	Description/Purpose
USB Module Version	No changeable options	Displays USB module version.
USB Controllers	No changeable options	Displays number and type of USB controllers (if any).
USB Devices	No changeable options	Displays number and type of connected USB devices (if any).
USB Mass Storage Driver Support	- Disabled - Enabled (Default)	Enables/Disables USB Mass Storage Driver Support.
MASS STORAGE DEVICES: [drive(s)]	- Auto (Default) - Floppy - Forced FDD - Hard Disk - CD-ROM	Auto enumerates devices according to their media format. Optical drives are emulated as 'CD-ROM'. Drives with no media will be emulated according to a drive type.

5.4.11 Advanced – Network Stack Configuration

Menu Path *Advanced > Network Stack Configuration*

The **Network Stack Configuration** allows users to enable/disable UEFI Network Stack, IPv4/IPv6 PXE (Pre-Boot Execution) support and configure PXE boot wait time and detects the media presence.

PXE allows a workstation to boot from a server on a network prior to booting the operating system on the local hard drive. A PXE-enabled workstation connects its NIC to the LAN via a jumper, which keeps the workstation connected to the network even when the power is turned off.

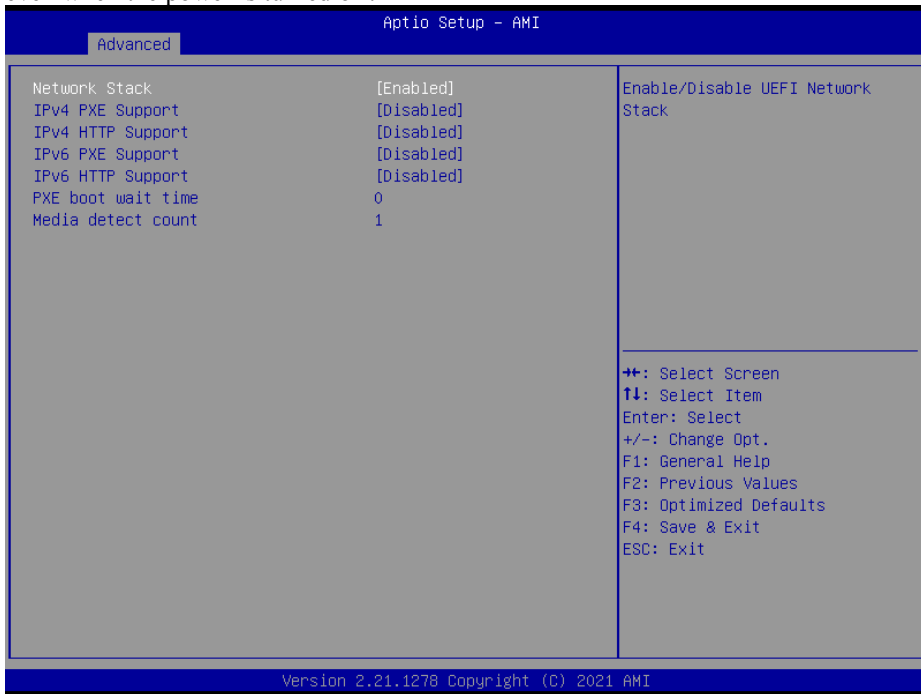

Network Stack Configuration Screen

BIOS Setting	Options	Description/Purpose
Network Stack	- Disabled (Default) - Enabled	Enables / Disables UEFI Network Stack.
IPv4 PXE Support	- Disabled (Default) - Enabled	Enables / Disables IPv4 PXE boot support. If disabled, IPv4 PXE boot support will not be available.
IPv4 HTTP Support	- Disabled (Default) - Enabled	Enables / Disables IPv4 HTTP boot support. If disabled, IPv4 HTTP boot support will not be available.

BIOS Setting	Options	Description/Purpose
IPv6 PXE Support	- Disabled (Default) - Enabled	Enable s/ Disables IPv6 PXE boot support. If disabled, IPv6 PXE boot support will not be available.
IPv6 HTTP Support	- Disabled (Default) - Enabled	Enables / Disables IPv6 HTTP boot support. If disabled, IPv4 HTTP boot support will not be available.
PXE boot wait time	Numeric (from 0 to 5)	Wait time to press ESC key to abort the PXE boot.
Media detect count	Numeric (from 1 to 50)	Numbers of times presence of media will be checked.

5.4.12 Advanced – NVMe Configuration

Menu Path *Advanced > NVMe Configuration*



NVMe Configuration Screen

BIOS Setting	Options	Description/Purpose
NVMe Configuration	No changeable options	Displays NVMe device.

5.5 Chipset

Menu Path *Chipset*

This menu allows users to configure advanced Chipset settings such as System Agent (SA) and PCH-IO configuration parameters.

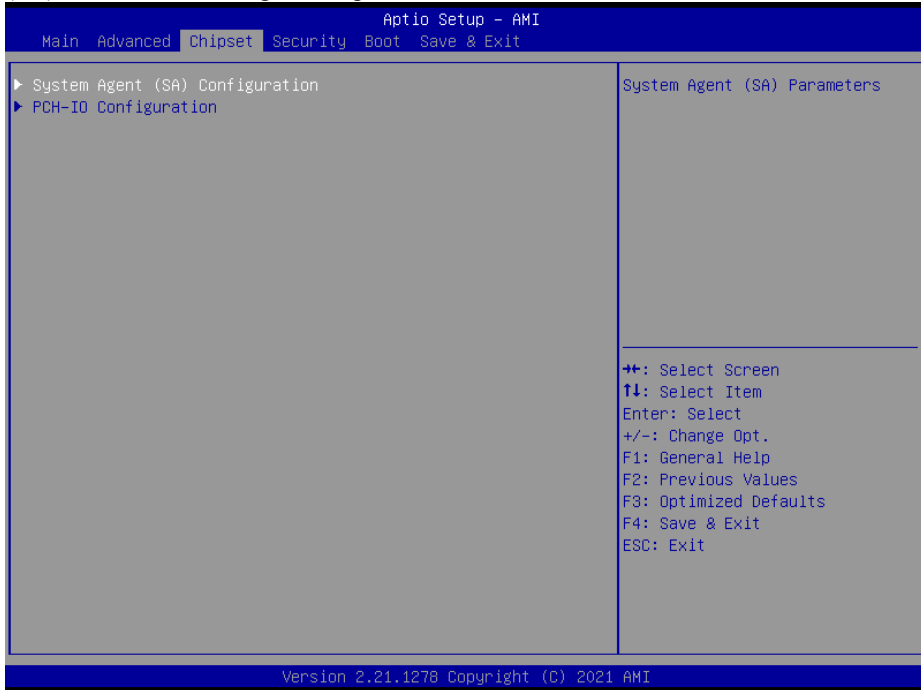

Chipset Screen

BIOS Setting	Options	Description/Purpose
System Agent (SA) Configuration	Sub-Menu	System Agent (SA) Parameters.
PCH-IO Configuration	Sub-Menu	PCH Parameters.

5.5.1 Chipset – System Agent (SA) Configuration

Menu Path *Chipset > System Agent (SA) Configuration*

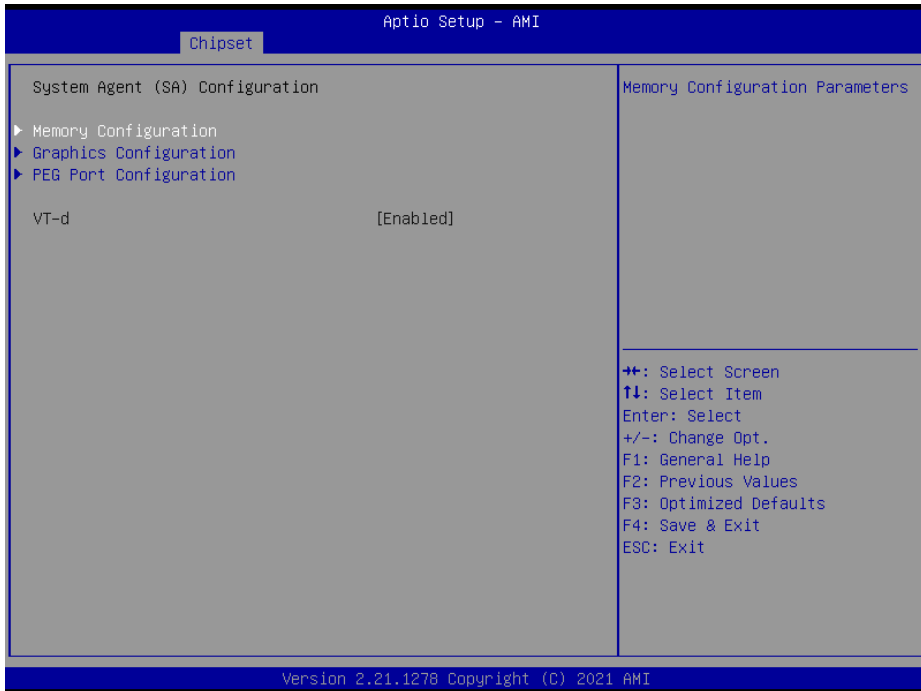

System Agent (SA) Configuration Screen

BIOS Setting	Options	Description/Purpose
Memory Configuration	Sub-Menu	Memory Configuration.
Graphics Configuration	Sub-Menu	Graphics Configuration.
PEG Port Configuration	Sub-Menu	PEG Port Configuration.
VT-d	- Disabled - Enabled (Default)	Enables or Disables VT-d function.

System Agent (SA) Configuration – Memory Configuration

Menu Path *Chipset > System Agent (SA) Configuration > Memory Configuration*



Memory Configuration Screen

BIOS Setting	Options	Description/Purpose
Memory Frequency	No changeable options	Displays the Frequency of Memory.
DIMM1	No changeable options	Displays the size of DIMM1.
DIMM2	No changeable options	Displays the size of DIMM2.

System Agent (SA) Configuration – Graphics Configuration

Menu Path *Chipset > System Agent (SA) Configuration > Graphics Configuration*

The **Graphics Configuration** allows users to configure the display settings for the LCD panel.

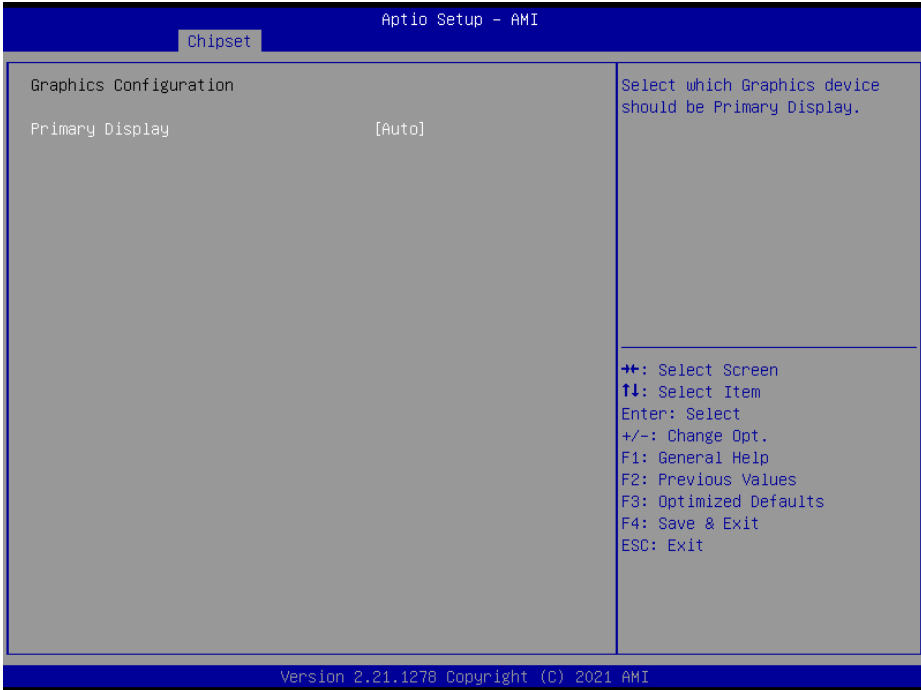

Graphics Configuration Screen

BIOS Setting	Options	Description/Purpose
Primary Display	- Auto (Default) - IGFX	Select the Graphics device that should be Primary Display.

System Agent (SA) Configuration – PEG Port Configuration

Menu Path *Chipset > System Agent (SA) Configuration > PEG Port Configuration*

The **PEG Port Configuration** allows users to display the PEG status, enable Root Port and configure the maximum speed for PCI Express x16 slot.

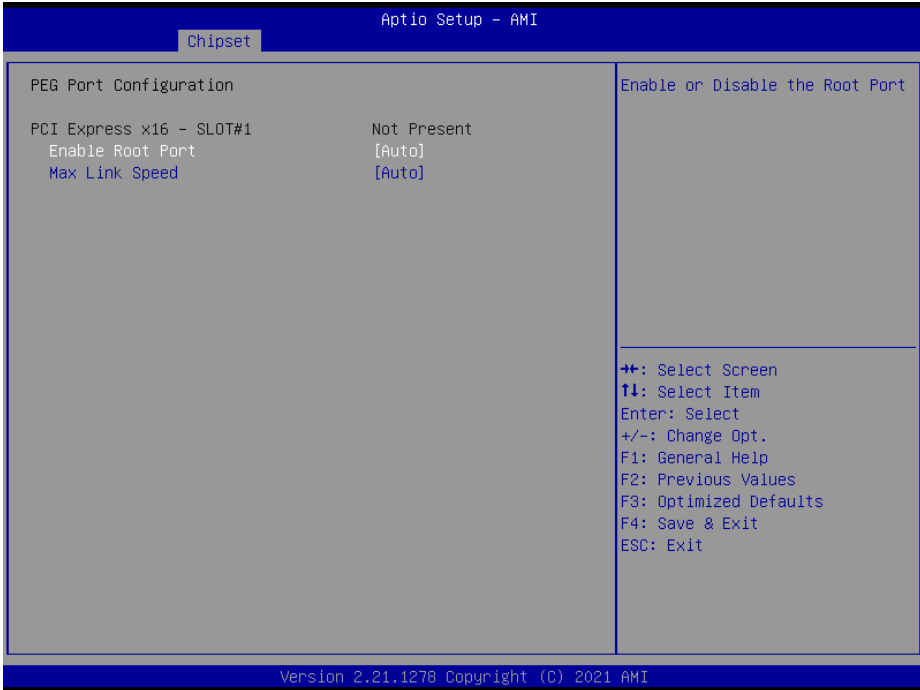

PEG Port Configuration Screen

BIOS Setting	Options	Description/Purpose
PCI Express x16 – SLOT#1	No changeable options	PCI Express x16 Slot Link and Speed information.
Enable Root Port	- Disabled - Enabled - Auto (Default)	Enables or Disables the Root Port.
Max Link Speed	- Auto (Default) - Gen1 - Gen2 - Gen3	Configures PCI-E1 Max Speed.

5.5.2 Chipset – PCH IO Configuration

Menu Path *Chipset > PCH-IO Configuration*

The **PCH-IO Configuration** allows users to configure PCI Express and SATA configuration parameters, enable/disable PCH LAN Controller and Wake-On-LAN function and determine the power on/off state that the system will go to following a power failure (G3 state).



PCH-IO Configuration Screen

BIOS Setting	Options	Description/Purpose
PCI Express Configuration	Sub-Menu	PCI Express Configuration settings.
SATA Configuration	Sub-Menu	SATA Configuration settings.
PCH LAN Controller	- Disabled - Enabled (Default)	Enables or Disables onboard NIC.
Wake On LAN Enable	- Disabled - Enabled (Default)	Enables or Disables integrated LAN to wake up the system.
Restore AC Power Loss	- Power On - Power Off (Default)	Specifies what state to go to when power is re-applied following a power failure (G3 state).

PCH-IO Configuration – PCI Express Configuration

Menu Path *Chipset > PCH-IO Configuration > PCI Express Configuration*

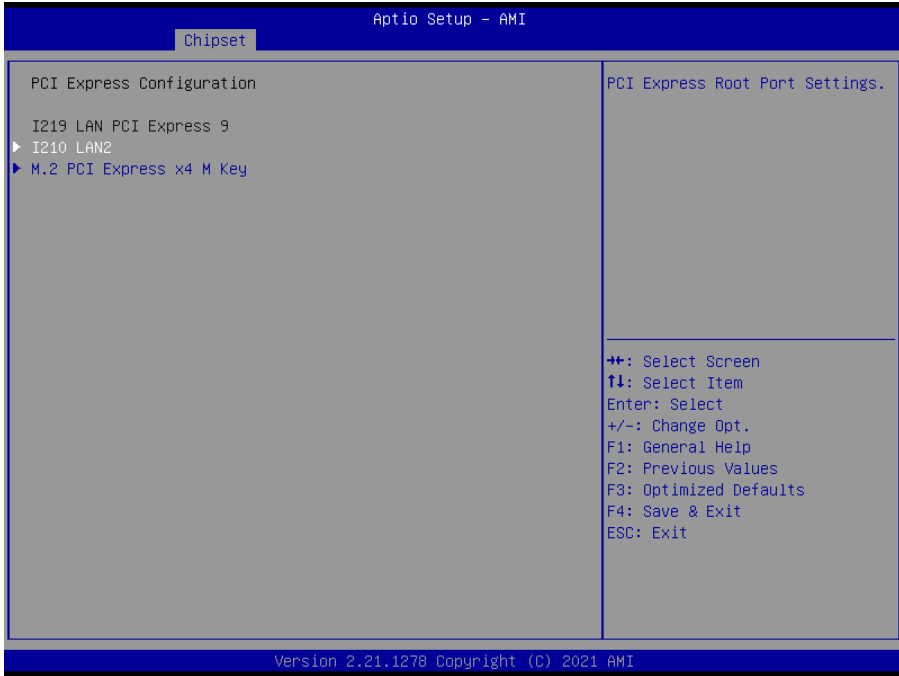

PCI Express Configuration Screen

BIOS Setting	Options	Description/Purpose
I219 LAN PCI Express 9	No changeable options	PCI Express 9 settings.
I219 LAN PCI Express 9	No changeable options	PCI Express 9 settings
I210 LAN2	Sub-Menu	PCI Express Root Port Settings
M.2 PCI Express x4 M Key <i>(for Q470/W480 only)</i>	Sub-Menu	PCI Express Root Port Settings.

PCH-IO Configuration – PCI Express Configuration – I210 LAN2

Menu Path *Chipset > PCH-IO Configuration > PCI Express Configuration > I210 LAN2*



I210 LAN2 Screen

BIOS Setting	Options	Description/Purpose
I210 LAN2	- Disabled - Enabled (Default)	Control the PCI Express Root Port
ASPM	- Disabled (Default) - L0s - L1 - L0sL1 - Auto	Sets the ASPM Level: <ul style="list-style-type: none"> • Force L0s - Force all links to L0s State. • Auto - BIOS auto configure. • Disabled - Disables ASPM.
L1 Substates	- Disabled (Default) - L1.1 - L1.1 & L1.2	PCI Express L1 Substates settings.
Hot Plug	- Disabled (Default) - Enabled	Hot Plug support enabled / disabled.
PCIe Speed	- Auto (Default) - Gen1 - Gen2 - Gen3	Configures PCIe Speed.

PCH-IO Configuration – PCI Express Configuration – M.2 PCI Express x4 M Key (for Q470E/W480E only)

Menu Path *Chipset > PCH-IO Configuration > PCI Express Configuration > M.2 PCI Express x4 M Key (for Q470E/W480E only)*

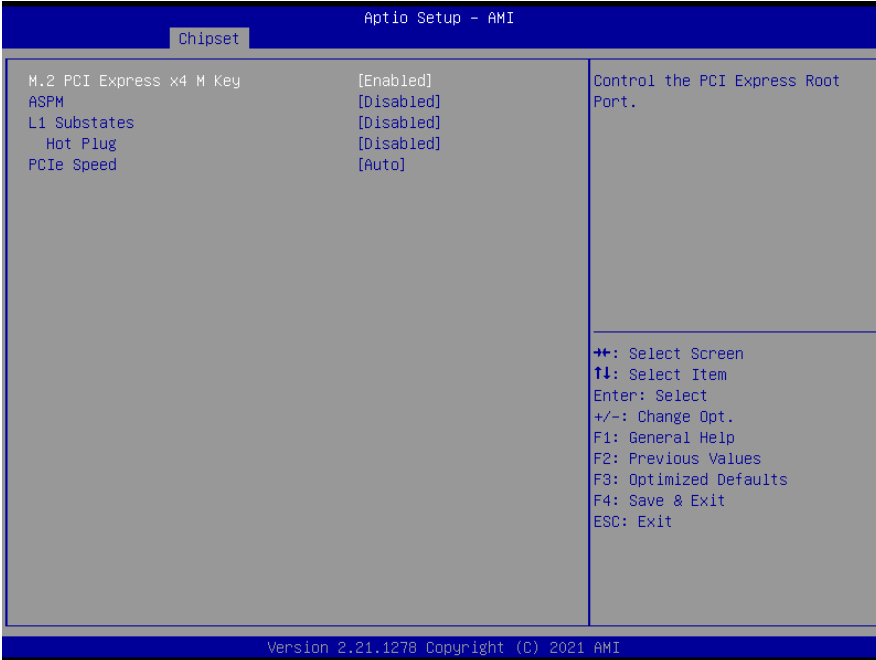

M.2 PCI Express x4 M Key Screen

BIOS Setting	Options	Description/Purpose
M.2 PCI Express x4 M Key	- Disabled - Enabled (Default)	Controls the PCI Express Root Port.
ASPM	- Disabled (Default) - L0s - L1 - L0sL1 - Auto	Sets the ASPM Level: <ul style="list-style-type: none"> • L0s - Force all links to L0s State • Auto - BIOS auto configure. • Disabled - Disables ASPM.
L1 Substates	- Disabled (Default) - L1.1 - L1.1 & L1.2	PCI Express L1 Substates settings.
Hot Plug	- Disabled (Default) - Enabled	Hot Plug support enabled / disabled.
PCIe Speed	- Auto (Default) - Gen1 - Gen2 - Gen3	Configures PCIe speed.

PCH-IO Configuration – SATA Configuration

Menu Path *Chipset > PCH-IO Configuration > SATA Configuration*

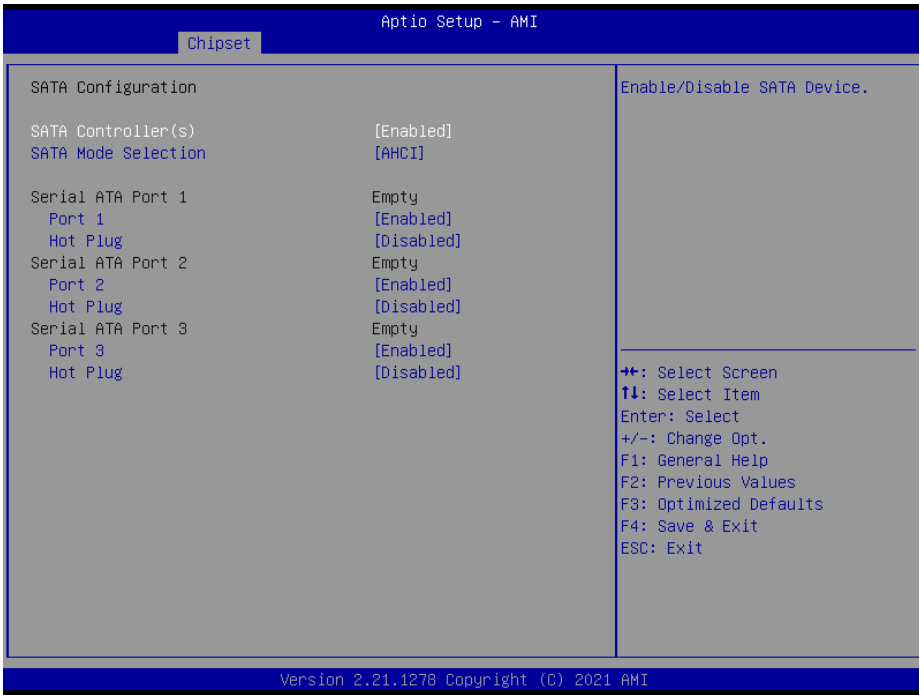

SATA Configuration Screen

BIOS Setting	Options	Description/Purpose
SATA Controller(s)	- Disabled (Default) - Enabled	Enables or Disables SATA Device.
SATA Mode Selection	- AHCI (Default) - Intel® RST (RAID)	Determines how SATA controller(s) operate.
Serial ATA Port 1 – 3	No changeable options	Displays the SATA device’s name.
Port 1 - 3	- Disabled - Enabled (Default)	Enables or Disables SATA Port Device.
Hot Plug	- Disabled (Default) - Enabled	Enables or Disables SATA Port Device Hot Plug function.

5.6 Security

Menu Path *Security*

From the **Security** menu, you are allowed to create, change or clear the administrator password. You will be asked to enter the configured administrator password before you can access the Setup Utility.

By setting an administrator password, you will prevent other users from changing your BIOS settings. You can configure an Administrator password and then configure a user password. An administrator has much more privileges over the settings in the Setup utility than a user. Heed that a user password does not provide access to most of the features in the Setup utility.



Security Screen

BIOS Setting	Options	Description/Purpose
Administrator Password	Password can be 3-20 alphanumeric characters.	Specifies the administrator password.
User Password	Password can be 3-20 alphanumeric characters.	Specifies the user password.

BIOS Setting	Options	Description/Purpose
HDD Security Configuration	Sub-Menu	Enters sub-menu with option to enabled password protected HDD/SSD (if supported by SATA device).

Create an Administrator or User Password

1. Select the **Administrator Password / User Password** option from the Security menu and press <Enter>, and the password dialog entry box appears.
2. Enter the password you want to create. A password can be 3-20 alphanumeric characters. After you have configured the password, press <Enter> to confirm.
3. Type the new password again and press <Enter>.

Change an Administrator or User Password

1. Select the **Administrator Password / User Password** option from the Security menu and press <Enter>, and the password dialog entry box appears.
2. Select the Administrator Password or User Password that you want to change. A password can be 3-20 alphanumeric characters. After you have changed the password, press <Enter> to confirm.
3. Type the changed password again and press <Enter>.

Remove an Administrator or User Password

1. Select the **Administrator Password / User Password** option from the Security menu and press <Enter>, and the password dialog entry box appears.
2. Select the configured Administrator Password or User Password that you want to delete. Leave the dialog box blank and press <Enter>.
3. Press <Enter> again when the password confirmation box appears.

5.7 Boot

Menu Path *Boot*

This menu provides control items for setting system boot configuration and boot priorities.

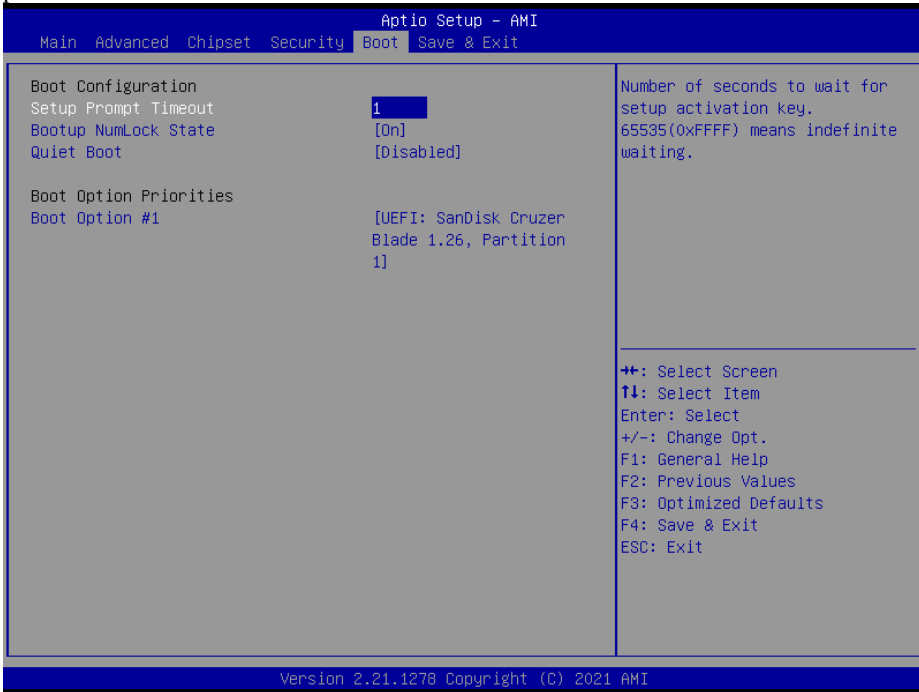

Boot Screen

BIOS Setting	Options	Description/Purpose
Setup Prompt Timeout	Numeric (from 1 to 65535)	Number of seconds to wait for setup activation key.
Bootup NumLock State	- On (Default) - Off	Specifies the power-on state of the NumLock Key.
Quiet Boot	- Disabled (Default) - Enabled	Enables or Disables Quiet Boot options.
Boot Option #1~#n	- [Drive(s)] - Disabled	Sets the system boot order.

5.8 Save & Exit

Menu Path	Save & Exit
-----------	-------------

The **Save & Exit** allows users to save or discard changed BIOS settings as well as load factory default settings.

Save Changed BIOS Settings

To save and validate the changed BIOS settings, select **Save Changes** from the **Save & Exit** menu, or you can select **Save Changes and Exit** (or press **F4**) to validate the changes and then exit the system. Select **Save Changes and Reset** to validate the changed BIOS settings and then restart the system.

Discard Changed BIOS Settings

To cancel the BIOS settings you have previously configured, select **Discard Changes and Exit** from this menu, or simply press **Esc** to exit the BIOS setup. You can also select **Discard Changes and Reset** to discard any changes you have made and restore the factory BIOS defaults.

Load User Defaults

You may simply press **F3** at any time to load the **Optimized Values** which resets all BIOS settings to the factory defaults.

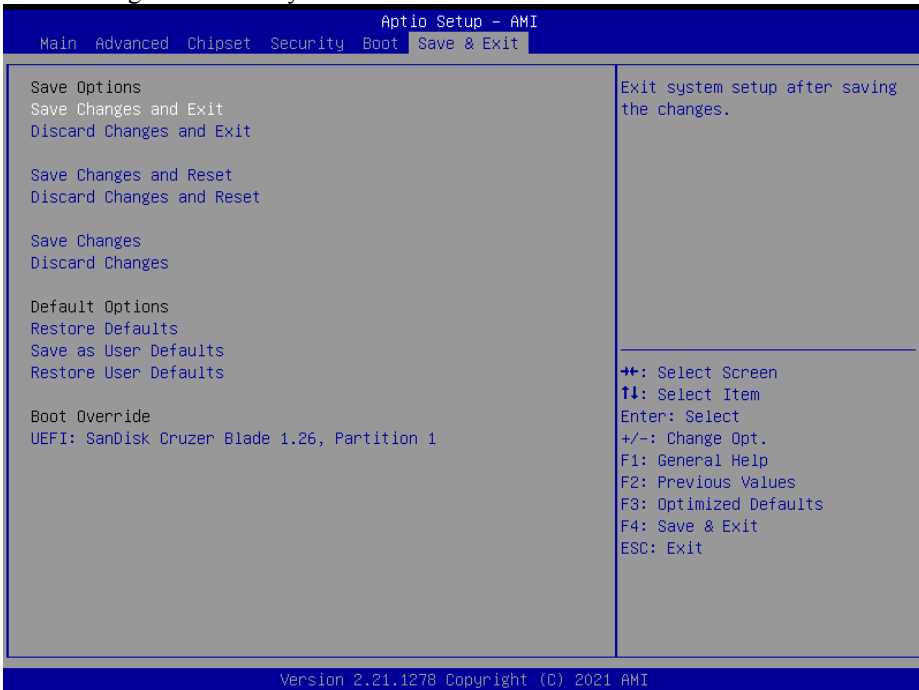

Save & Exit Screen

BIOS Setting	Options	Description/Purpose
Save Changes and Exit	No changeable options	Exits and saves the changes in NVRAM.
Discard Changes and Exit	No changeable options	Exits without saving any changes made in BIOS settings.
Save Changes and Reset	No changeable options	Saves the changes in NVRAM and resets.
Discard Changes and Reset	No changeable options	Resets without saving any changes made in BIOS settings.
Save Changes	No changeable options	Saves Changes done so far to any of the setup options.
Discard Changes	No changeable options	Discards Changes done so far to any of the setup options.
Restore Defaults	No changeable options	Loads the optimized defaults for BIOS settings.
Save as User Defaults	No changeable options	Saves the changes done so far as User Defaults.
Restore User Defaults	No changeable options	Restores the User Defaults to all the setup options.
Boot Override	- [Drive(s)]	Forces to boot from selected [drive(s)].

Appendix A Technical Summary

This appendix will give you a brief introduction of the allocation maps for BM-D025 resources.

The following topics are included:

- BM-D025 Block Diagram
- Interrupt Map
- I/O Map
- Memory Map
- DMA Map
- Configuring WatchDog Timer
- Flash BIOS Update

BM-D025 Block Diagram

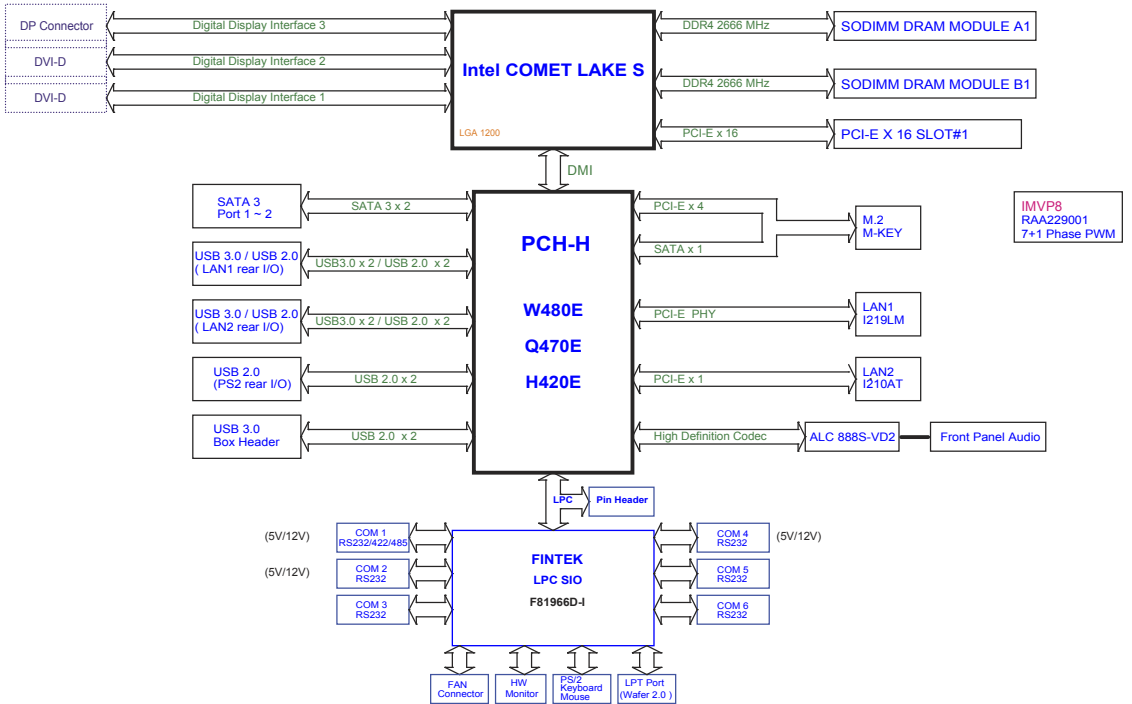

Interrupt Map

IRQ	ASSIGNMENT
IRQ 0	System timer
IRQ 1	Standard PS/2 Keyboard
IRQ 3	Communications Port (COM2)
IRQ 4	Communications Port (COM1)
IRQ 6	Communications Port (COM4)
IRQ 7	Communications Port (COM3)
IRQ 10	Communications Port (COM5)
IRQ 11	Communications Port (COM6)
IRQ 12	PS/2 Compatible Mouse
IRQ 13	Numeric data processor
IRQ 14	Intel® Serial IO GPIO Host Controller - INT3450
IRQ 16	Intel® Serial IO I2C Host Controller - A368
IRQ 16	High Definition Audio Controller
IRQ 17	Intel® Serial IO I2C Host Controller - A369
IRQ 19	Intel® Active Management Technology - SOL (COM8)
IRQ 45	Trusted Platform Module 2.0
IRQ 54	Microsoft ACPI-Compliant System
IRQ 55	Microsoft ACPI-Compliant System
IRQ 56	Microsoft ACPI-Compliant System
IRQ 57	Microsoft ACPI-Compliant System
IRQ 58	Microsoft ACPI-Compliant System
IRQ 59	Microsoft ACPI-Compliant System
IRQ 60	Microsoft ACPI-Compliant System
IRQ 61	Microsoft ACPI-Compliant System
IRQ 62	Microsoft ACPI-Compliant System
IRQ 63	Microsoft ACPI-Compliant System
IRQ 64	Microsoft ACPI-Compliant System
IRQ 65	Microsoft ACPI-Compliant System
IRQ 66	Microsoft ACPI-Compliant System
IRQ 67	Microsoft ACPI-Compliant System
IRQ 68	Microsoft ACPI-Compliant System
IRQ 69	Microsoft ACPI-Compliant System
IRQ 70	Microsoft ACPI-Compliant System
IRQ 71	Microsoft ACPI-Compliant System

IRQ	ASSIGNMENT
IRQ 72	Microsoft ACPI-Compliant System
IRQ 73	Microsoft ACPI-Compliant System
IRQ 74	Microsoft ACPI-Compliant System
IRQ 75	Microsoft ACPI-Compliant System
IRQ 76	Microsoft ACPI-Compliant System
IRQ 77	Microsoft ACPI-Compliant System
IRQ 78	Microsoft ACPI-Compliant System
IRQ 79	Microsoft ACPI-Compliant System
IRQ 80	Microsoft ACPI-Compliant System
IRQ 81	Microsoft ACPI-Compliant System
IRQ 82	Microsoft ACPI-Compliant System
IRQ 83	Microsoft ACPI-Compliant System
IRQ 84	Microsoft ACPI-Compliant System
IRQ 85	Microsoft ACPI-Compliant System
IRQ 86	Microsoft ACPI-Compliant System
IRQ 87	Microsoft ACPI-Compliant System
IRQ 88	Microsoft ACPI-Compliant System
IRQ 89	Microsoft ACPI-Compliant System
IRQ 90	Microsoft ACPI-Compliant System
IRQ 91	Microsoft ACPI-Compliant System
IRQ 92	Microsoft ACPI-Compliant System
IRQ 93	Microsoft ACPI-Compliant System
IRQ 94	Microsoft ACPI-Compliant System
IRQ 95	Microsoft ACPI-Compliant System
IRQ 96	Microsoft ACPI-Compliant System
IRQ 97	Microsoft ACPI-Compliant System
IRQ 98	Microsoft ACPI-Compliant System
IRQ 99	Microsoft ACPI-Compliant System
IRQ 100	Microsoft ACPI-Compliant System
IRQ 101	Microsoft ACPI-Compliant System
IRQ 102	Microsoft ACPI-Compliant System
IRQ 103	Microsoft ACPI-Compliant System
IRQ 104	Microsoft ACPI-Compliant System

IRQ	ASSIGNMENT
IRQ 105	Microsoft ACPI-Compliant System
IRQ 106	Microsoft ACPI-Compliant System
IRQ 107	Microsoft ACPI-Compliant System
IRQ 108	Microsoft ACPI-Compliant System
IRQ 109	Microsoft ACPI-Compliant System
IRQ 110	Microsoft ACPI-Compliant System
IRQ 111	Microsoft ACPI-Compliant System
IRQ 112	Microsoft ACPI-Compliant System
IRQ 113	Microsoft ACPI-Compliant System
IRQ 114	Microsoft ACPI-Compliant System
IRQ 115	Microsoft ACPI-Compliant System
IRQ 116	Microsoft ACPI-Compliant System
IRQ 117	Microsoft ACPI-Compliant System
IRQ 118	Microsoft ACPI-Compliant System
IRQ 119	Microsoft ACPI-Compliant System
IRQ 120	Microsoft ACPI-Compliant System
IRQ 121	Microsoft ACPI-Compliant System
IRQ 122	Microsoft ACPI-Compliant System
IRQ 123	Microsoft ACPI-Compliant System
IRQ 124	Microsoft ACPI-Compliant System
IRQ 125	Microsoft ACPI-Compliant System
IRQ 126	Microsoft ACPI-Compliant System
IRQ 127	Microsoft ACPI-Compliant System
IRQ 128	Microsoft ACPI-Compliant System
IRQ 129	Microsoft ACPI-Compliant System
IRQ 130	Microsoft ACPI-Compliant System
IRQ 131	Microsoft ACPI-Compliant System
IRQ 132	Microsoft ACPI-Compliant System
IRQ 133	Microsoft ACPI-Compliant System
IRQ 134	Microsoft ACPI-Compliant System
IRQ 135	Microsoft ACPI-Compliant System
IRQ 136	Microsoft ACPI-Compliant System
IRQ 137	Microsoft ACPI-Compliant System
IRQ 138	Microsoft ACPI-Compliant System
IRQ 139	Microsoft ACPI-Compliant System

IRQ	ASSIGNMENT
IRQ 140	Microsoft ACPI-Compliant System
IRQ 141	Microsoft ACPI-Compliant System
IRQ 142	Microsoft ACPI-Compliant System
IRQ 143	Microsoft ACPI-Compliant System
IRQ 144	Microsoft ACPI-Compliant System
IRQ 145	Microsoft ACPI-Compliant System
IRQ 146	Microsoft ACPI-Compliant System
IRQ 147	Microsoft ACPI-Compliant System
IRQ 148	Microsoft ACPI-Compliant System
IRQ 149	Microsoft ACPI-Compliant System
IRQ 150	Microsoft ACPI-Compliant System
IRQ 151	Microsoft ACPI-Compliant System
IRQ 152	Microsoft ACPI-Compliant System
IRQ 153	Microsoft ACPI-Compliant System
IRQ 154	Microsoft ACPI-Compliant System
IRQ 155	Microsoft ACPI-Compliant System
IRQ 156	Microsoft ACPI-Compliant System
IRQ 157	Microsoft ACPI-Compliant System
IRQ 158	Microsoft ACPI-Compliant System
IRQ 159	Microsoft ACPI-Compliant System
IRQ 160	Microsoft ACPI-Compliant System
IRQ 161	Microsoft ACPI-Compliant System
IRQ 162	Microsoft ACPI-Compliant System
IRQ 163	Microsoft ACPI-Compliant System
IRQ 164	Microsoft ACPI-Compliant System
IRQ 165	Microsoft ACPI-Compliant System
IRQ 166	Microsoft ACPI-Compliant System
IRQ 167	Microsoft ACPI-Compliant System
IRQ 168	Microsoft ACPI-Compliant System
IRQ 169	Microsoft ACPI-Compliant System
IRQ 170	Microsoft ACPI-Compliant System
IRQ 171	Microsoft ACPI-Compliant System
IRQ 172	Microsoft ACPI-Compliant System

IRQ	ASSIGNMENT
IRQ 173	Microsoft ACPI-Compliant System
IRQ 174	Microsoft ACPI-Compliant System
IRQ 175	Microsoft ACPI-Compliant System
IRQ 176	Microsoft ACPI-Compliant System
IRQ 177	Microsoft ACPI-Compliant System
IRQ 178	Microsoft ACPI-Compliant System
IRQ 179	Microsoft ACPI-Compliant System
IRQ 180	Microsoft ACPI-Compliant System
IRQ 181	Microsoft ACPI-Compliant System
IRQ 182	Microsoft ACPI-Compliant System
IRQ 183	Microsoft ACPI-Compliant System
IRQ 184	Microsoft ACPI-Compliant System
IRQ 185	Microsoft ACPI-Compliant System
IRQ 186	Microsoft ACPI-Compliant System
IRQ 187	Microsoft ACPI-Compliant System
IRQ 188	Microsoft ACPI-Compliant System
IRQ 189	Microsoft ACPI-Compliant System
IRQ 190	Microsoft ACPI-Compliant System
IRQ 191	Microsoft ACPI-Compliant System
IRQ 192	Microsoft ACPI-Compliant System
IRQ 193	Microsoft ACPI-Compliant System
IRQ 194	Microsoft ACPI-Compliant System
IRQ 195	Microsoft ACPI-Compliant System
IRQ 196	Microsoft ACPI-Compliant System
IRQ 197	Microsoft ACPI-Compliant System
IRQ 198	Microsoft ACPI-Compliant System
IRQ 199	Microsoft ACPI-Compliant System
IRQ 200	Microsoft ACPI-Compliant System
IRQ 201	Microsoft ACPI-Compliant System
IRQ 202	Microsoft ACPI-Compliant System
IRQ 203	Microsoft ACPI-Compliant System
IRQ 204	Microsoft ACPI-Compliant System
IRQ 256	Microsoft ACPI-Compliant System
IRQ 257	Microsoft ACPI-Compliant System
IRQ 258	Microsoft ACPI-Compliant System

IRQ	ASSIGNMENT
IRQ 259	Microsoft ACPI-Compliant System
IRQ 260	Microsoft ACPI-Compliant System
IRQ 261	Microsoft ACPI-Compliant System
IRQ 262	Microsoft ACPI-Compliant System
IRQ 263	Microsoft ACPI-Compliant System
IRQ 264	Microsoft ACPI-Compliant System
IRQ 265	Microsoft ACPI-Compliant System
IRQ 266	Microsoft ACPI-Compliant System
IRQ 267	Microsoft ACPI-Compliant System
IRQ 268	Microsoft ACPI-Compliant System
IRQ 269	Microsoft ACPI-Compliant System
IRQ 270	Microsoft ACPI-Compliant System
IRQ 271	Microsoft ACPI-Compliant System
IRQ 272	Microsoft ACPI-Compliant System
IRQ 273	Microsoft ACPI-Compliant System
IRQ 274	Microsoft ACPI-Compliant System
IRQ 275	Microsoft ACPI-Compliant System
IRQ 276	Microsoft ACPI-Compliant System
IRQ 277	Microsoft ACPI-Compliant System
IRQ 278	Microsoft ACPI-Compliant System
IRQ 279	Microsoft ACPI-Compliant System
IRQ 280	Microsoft ACPI-Compliant System
IRQ 281	Microsoft ACPI-Compliant System
IRQ 282	Microsoft ACPI-Compliant System
IRQ 283	Microsoft ACPI-Compliant System
IRQ 284	Microsoft ACPI-Compliant System
IRQ 285	Microsoft ACPI-Compliant System
IRQ 286	Microsoft ACPI-Compliant System
IRQ 287	Microsoft ACPI-Compliant System
IRQ 288	Microsoft ACPI-Compliant System
IRQ 289	Microsoft ACPI-Compliant System
IRQ 290	Microsoft ACPI-Compliant System
IRQ 291	Microsoft ACPI-Compliant System

IRQ	ASSIGNMENT
IRQ 292	Microsoft ACPI-Compliant System
IRQ 293	Microsoft ACPI-Compliant System
IRQ 294	Microsoft ACPI-Compliant System
IRQ 295	Microsoft ACPI-Compliant System
IRQ 296	Microsoft ACPI-Compliant System
IRQ 297	Microsoft ACPI-Compliant System
IRQ 298	Microsoft ACPI-Compliant System
IRQ 299	Microsoft ACPI-Compliant System
IRQ 300	Microsoft ACPI-Compliant System
IRQ 301	Microsoft ACPI-Compliant System
IRQ 302	Microsoft ACPI-Compliant System
IRQ 303	Microsoft ACPI-Compliant System
IRQ 304	Microsoft ACPI-Compliant System
IRQ 305	Microsoft ACPI-Compliant System
IRQ 306	Microsoft ACPI-Compliant System
IRQ 307	Microsoft ACPI-Compliant System
IRQ 308	Microsoft ACPI-Compliant System
IRQ 309	Microsoft ACPI-Compliant System
IRQ 310	Microsoft ACPI-Compliant System
IRQ 311	Microsoft ACPI-Compliant System
IRQ 312	Microsoft ACPI-Compliant System
IRQ 313	Microsoft ACPI-Compliant System
IRQ 314	Microsoft ACPI-Compliant System
IRQ 315	Microsoft ACPI-Compliant System
IRQ 316	Microsoft ACPI-Compliant System
IRQ 317	Microsoft ACPI-Compliant System
IRQ 318	Microsoft ACPI-Compliant System
IRQ 319	Microsoft ACPI-Compliant System
IRQ 320	Microsoft ACPI-Compliant System
IRQ 321	Microsoft ACPI-Compliant System
IRQ 322	Microsoft ACPI-Compliant System
IRQ 323	Microsoft ACPI-Compliant System
IRQ 324	Microsoft ACPI-Compliant System
IRQ 325	Microsoft ACPI-Compliant System
IRQ 326	Microsoft ACPI-Compliant System

IRQ	ASSIGNMENT
IRQ 327	Microsoft ACPI-Compliant System
IRQ 328	Microsoft ACPI-Compliant System
IRQ 329	Microsoft ACPI-Compliant System
IRQ 330	Microsoft ACPI-Compliant System
IRQ 331	Microsoft ACPI-Compliant System
IRQ 332	Microsoft ACPI-Compliant System
IRQ 333	Microsoft ACPI-Compliant System
IRQ 334	Microsoft ACPI-Compliant System
IRQ 335	Microsoft ACPI-Compliant System
IRQ 336	Microsoft ACPI-Compliant System
IRQ 337	Microsoft ACPI-Compliant System
IRQ 338	Microsoft ACPI-Compliant System
IRQ 339	Microsoft ACPI-Compliant System
IRQ 340	Microsoft ACPI-Compliant System
IRQ 341	Microsoft ACPI-Compliant System
IRQ 342	Microsoft ACPI-Compliant System
IRQ 343	Microsoft ACPI-Compliant System
IRQ 344	Microsoft ACPI-Compliant System
IRQ 345	Microsoft ACPI-Compliant System
IRQ 346	Microsoft ACPI-Compliant System
IRQ 347	Microsoft ACPI-Compliant System
IRQ 348	Microsoft ACPI-Compliant System
IRQ 349	Microsoft ACPI-Compliant System
IRQ 350	Microsoft ACPI-Compliant System
IRQ 351	Microsoft ACPI-Compliant System
IRQ 352	Microsoft ACPI-Compliant System
IRQ 353	Microsoft ACPI-Compliant System
IRQ 354	Microsoft ACPI-Compliant System
IRQ 355	Microsoft ACPI-Compliant System
IRQ 356	Microsoft ACPI-Compliant System
IRQ 357	Microsoft ACPI-Compliant System
IRQ 358	Microsoft ACPI-Compliant System
IRQ 359	Microsoft ACPI-Compliant System

IRQ	ASSIGNMENT
IRQ 360	Microsoft ACPI-Compliant System
IRQ 361	Microsoft ACPI-Compliant System
IRQ 362	Microsoft ACPI-Compliant System
IRQ 363	Microsoft ACPI-Compliant System
IRQ 364	Microsoft ACPI-Compliant System
IRQ 365	Microsoft ACPI-Compliant System
IRQ 366	Microsoft ACPI-Compliant System
IRQ 367	Microsoft ACPI-Compliant System
IRQ 368	Microsoft ACPI-Compliant System
IRQ 369	Microsoft ACPI-Compliant System
IRQ 370	Microsoft ACPI-Compliant System
IRQ 371	Microsoft ACPI-Compliant System
IRQ 372	Microsoft ACPI-Compliant System
IRQ 373	Microsoft ACPI-Compliant System
IRQ 374	Microsoft ACPI-Compliant System
IRQ 375	Microsoft ACPI-Compliant System
IRQ 376	Microsoft ACPI-Compliant System
IRQ 377	Microsoft ACPI-Compliant System
IRQ 378	Microsoft ACPI-Compliant System
IRQ 379	Microsoft ACPI-Compliant System
IRQ 380	Microsoft ACPI-Compliant System
IRQ 381	Microsoft ACPI-Compliant System
IRQ 382	Microsoft ACPI-Compliant System
IRQ 383	Microsoft ACPI-Compliant System
IRQ 384	Microsoft ACPI-Compliant System
IRQ 385	Microsoft ACPI-Compliant System
IRQ 386	Microsoft ACPI-Compliant System
IRQ 387	Microsoft ACPI-Compliant System
IRQ 388	Microsoft ACPI-Compliant System
IRQ 389	Microsoft ACPI-Compliant System
IRQ 390	Microsoft ACPI-Compliant System
IRQ 391	Microsoft ACPI-Compliant System
IRQ 392	Microsoft ACPI-Compliant System
IRQ 393	Microsoft ACPI-Compliant System
IRQ 394	Microsoft ACPI-Compliant System

IRQ	ASSIGNMENT
IRQ 395	Microsoft ACPI-Compliant System
IRQ 396	Microsoft ACPI-Compliant System
IRQ 397	Microsoft ACPI-Compliant System
IRQ 398	Microsoft ACPI-Compliant System
IRQ 399	Microsoft ACPI-Compliant System
IRQ 400	Microsoft ACPI-Compliant System
IRQ 401	Microsoft ACPI-Compliant System
IRQ 402	Microsoft ACPI-Compliant System
IRQ 403	Microsoft ACPI-Compliant System
IRQ 404	Microsoft ACPI-Compliant System
IRQ 405	Microsoft ACPI-Compliant System
IRQ 406	Microsoft ACPI-Compliant System
IRQ 407	Microsoft ACPI-Compliant System
IRQ 408	Microsoft ACPI-Compliant System
IRQ 409	Microsoft ACPI-Compliant System
IRQ 410	Microsoft ACPI-Compliant System
IRQ 411	Microsoft ACPI-Compliant System
IRQ 412	Microsoft ACPI-Compliant System
IRQ 413	Microsoft ACPI-Compliant System
IRQ 414	Microsoft ACPI-Compliant System
IRQ 415	Microsoft ACPI-Compliant System
IRQ 416	Microsoft ACPI-Compliant System
IRQ 417	Microsoft ACPI-Compliant System
IRQ 418	Microsoft ACPI-Compliant System
IRQ 419	Microsoft ACPI-Compliant System
IRQ 420	Microsoft ACPI-Compliant System
IRQ 421	Microsoft ACPI-Compliant System
IRQ 422	Microsoft ACPI-Compliant System
IRQ 423	Microsoft ACPI-Compliant System
IRQ 424	Microsoft ACPI-Compliant System
IRQ 425	Microsoft ACPI-Compliant System
IRQ 426	Microsoft ACPI-Compliant System
IRQ 427	Microsoft ACPI-Compliant System

IRQ	ASSIGNMENT
IRQ 428	Microsoft ACPI-Compliant System
IRQ 429	Microsoft ACPI-Compliant System
IRQ 430	Microsoft ACPI-Compliant System
IRQ 431	Microsoft ACPI-Compliant System
IRQ 432	Microsoft ACPI-Compliant System
IRQ 433	Microsoft ACPI-Compliant System
IRQ 434	Microsoft ACPI-Compliant System
IRQ 435	Microsoft ACPI-Compliant System
IRQ 436	Microsoft ACPI-Compliant System
IRQ 437	Microsoft ACPI-Compliant System
IRQ 438	Microsoft ACPI-Compliant System
IRQ 439	Microsoft ACPI-Compliant System
IRQ 440	Microsoft ACPI-Compliant System
IRQ 441	Microsoft ACPI-Compliant System
IRQ 442	Microsoft ACPI-Compliant System
IRQ 443	Microsoft ACPI-Compliant System
IRQ 444	Microsoft ACPI-Compliant System
IRQ 445	Microsoft ACPI-Compliant System
IRQ 446	Microsoft ACPI-Compliant System
IRQ 447	Microsoft ACPI-Compliant System
IRQ 448	Microsoft ACPI-Compliant System
IRQ 449	Microsoft ACPI-Compliant System
IRQ 450	Microsoft ACPI-Compliant System
IRQ 451	Microsoft ACPI-Compliant System
IRQ 452	Microsoft ACPI-Compliant System
IRQ 453	Microsoft ACPI-Compliant System
IRQ 454	Microsoft ACPI-Compliant System
IRQ 455	Microsoft ACPI-Compliant System
IRQ 456	Microsoft ACPI-Compliant System
IRQ 457	Microsoft ACPI-Compliant System
IRQ 458	Microsoft ACPI-Compliant System
IRQ 459	Microsoft ACPI-Compliant System
IRQ 460	Microsoft ACPI-Compliant System
IRQ 461	Microsoft ACPI-Compliant System
IRQ 462	Microsoft ACPI-Compliant System

IRQ	ASSIGNMENT
IRQ 463	Microsoft ACPI-Compliant System
IRQ 464	Microsoft ACPI-Compliant System
IRQ 465	Microsoft ACPI-Compliant System
IRQ 466	Microsoft ACPI-Compliant System
IRQ 467	Microsoft ACPI-Compliant System
IRQ 468	Microsoft ACPI-Compliant System
IRQ 469	Microsoft ACPI-Compliant System
IRQ 470	Microsoft ACPI-Compliant System
IRQ 471	Microsoft ACPI-Compliant System
IRQ 472	Microsoft ACPI-Compliant System
IRQ 473	Microsoft ACPI-Compliant System
IRQ 474	Microsoft ACPI-Compliant System
IRQ 475	Microsoft ACPI-Compliant System
IRQ 476	Microsoft ACPI-Compliant System
IRQ 477	Microsoft ACPI-Compliant System
IRQ 478	Microsoft ACPI-Compliant System
IRQ 479	Microsoft ACPI-Compliant System
IRQ 480	Microsoft ACPI-Compliant System
IRQ 481	Microsoft ACPI-Compliant System
IRQ 482	Microsoft ACPI-Compliant System
IRQ 483	Microsoft ACPI-Compliant System
IRQ 484	Microsoft ACPI-Compliant System
IRQ 485	Microsoft ACPI-Compliant System
IRQ 486	Microsoft ACPI-Compliant System
IRQ 487	Microsoft ACPI-Compliant System
IRQ 488	Microsoft ACPI-Compliant System
IRQ 489	Microsoft ACPI-Compliant System
IRQ 490	Microsoft ACPI-Compliant System
IRQ 491	Microsoft ACPI-Compliant System
IRQ 492	Microsoft ACPI-Compliant System
IRQ 493	Microsoft ACPI-Compliant System
IRQ 494	Microsoft ACPI-Compliant System
IRQ 495	Microsoft ACPI-Compliant System

IRQ	ASSIGNMENT
IRQ 496	Microsoft ACPI-Compliant System
IRQ 497	Microsoft ACPI-Compliant System
IRQ 498	Microsoft ACPI-Compliant System
IRQ 499	Microsoft ACPI-Compliant System
IRQ 500	Microsoft ACPI-Compliant System
IRQ 501	Microsoft ACPI-Compliant System
IRQ 502	Microsoft ACPI-Compliant System
IRQ 503	Microsoft ACPI-Compliant System
IRQ 504	Microsoft ACPI-Compliant System
IRQ 505	Microsoft ACPI-Compliant System
IRQ 506	Microsoft ACPI-Compliant System
IRQ 507	Microsoft ACPI-Compliant System
IRQ 508	Microsoft ACPI-Compliant System
IRQ 509	Microsoft ACPI-Compliant System
IRQ 510	Microsoft ACPI-Compliant System
IRQ 511	Microsoft ACPI-Compliant System
IRQ 4294967280	Intel® Management Engine Interface
IRQ 4294967281	Intel® Ethernet Connection (7) I219-LM
IRQ 4294967282	Intel® I210 Gigabit Network Connection
IRQ 4294967283	Intel® I210 Gigabit Network Connection
IRQ 4294967284	Intel® I210 Gigabit Network Connection
IRQ 4294967285	Intel® I210 Gigabit Network Connection
IRQ 4294967286	Intel® I210 Gigabit Network Connection
IRQ 4294967287	Intel® I210 Gigabit Network Connection
IRQ 4294967288	Intel® I210 Gigabit Network Connection
IRQ 4294967289	Intel® I210 Gigabit Network Connection
IRQ 4294967290	Intel® I210 Gigabit Network Connection
IRQ 4294967291	Intel® I210 Gigabit Network Connection
IRQ 4294967292	Intel® USB 3.1 eXtensible Host Controller - 1.10 (Microsoft)
IRQ 4294967293	Intel® UHD Graphics P630
IRQ 4294967294	Standard SATA AHCI Controller

Note: These resource information were gathered using Windows 10 (the IRQ could be assigned differently depending on OS).

I/O MAP

I/O	ASSIGNMENT
0x00000000-0x00000CF7	PCI Express Root Complex
0x00000020-0x00000021	Programmable interrupt controller
0x00000024-0x00000025	Programmable interrupt controller
0x00000028-0x00000029	Programmable interrupt controller
0x0000002C-0x0000002D	Programmable interrupt controller
0x0000002E-0x0000002F	Motherboard resources
0x00000030-0x00000031	Programmable interrupt controller
0x00000034-0x00000035	Programmable interrupt controller
0x00000038-0x00000039	Programmable interrupt controller
0x0000003C-0x0000003D	Programmable interrupt controller
0x00000040-0x00000043	System timer
0x0000004E-0x0000004F	Motherboard resources
0x00000050-0x00000053	System timer
0x00000060-0x00000060	Standard PS/2 Keyboard
0x00000061-0x00000061	Motherboard resources
0x00000063-0x00000063	Motherboard resources
0x00000064-0x00000064	Standard PS/2 Keyboard
0x00000065-0x00000065	Motherboard resources
0x00000067-0x00000067	Motherboard resources
0x00000070-0x00000070	Motherboard resources
0x00000080-0x00000080	Motherboard resources
0x00000092-0x00000092	Motherboard resources
0x000000A0-0x000000A1	Programmable interrupt controller
0x000000A4-0x000000A5	Programmable interrupt controller
0x000000A8-0x000000A9	Programmable interrupt controller
0x000000AC-0x000000AD	Programmable interrupt controller
0x000000B0-0x000000B1	Programmable interrupt controller
0x000000B2-0x000000B3	Motherboard resources
0x000000B4-0x000000B5	Programmable interrupt controller
0x000000B8-0x000000B9	Programmable interrupt controller
0x000000BC-0x000000BD	Programmable interrupt controller
0x000000F0-0x000000F0	Numeric data processor

I/O	ASSIGNMENT
0x000002E0-0x000002E7	Communications Port (COM6)
0x000002E8-0x000002EF	Communications Port (COM4)
0x000002F0-0x000002F7	Communications Port (COM5)
0x000002F8-0x000002FF	Communications Port (COM2)
0x00000378-0x0000037F	Printer Port (LPT1)
0x000003E8-0x000003EF	Communications Port (COM3)
0x000003F8-0x000003FF	Communications Port (COM1)
0x000004D0-0x000004D1	Programmable interrupt controller
0x00000680-0x0000069F	Motherboard resources
0x00000A00-0x00000A0F	Motherboard resources
0x00000A10-0x00000A1F	Motherboard resources
0x00000A20-0x00000A2F	Motherboard resources
0x00000D00-0x0000FFFF	PCI Express Root Complex
0x0000164E-0x0000164F	Motherboard resources
0x00001800-0x000018FE	Motherboard resources
0x00001854-0x00001857	Motherboard resources
0x00002000-0x000020FE	Motherboard resources
0x00003000-0x00003FFF	Intel® PCI Express Root Port #11 - A332
0x00004000-0x0000403F	Intel® UHD Graphics P630
0x00004060-0x0000407F	Standard SATA AHCI Controller
0x00004080-0x00004083	Standard SATA AHCI Controller
0x00004090-0x00004097	Standard SATA AHCI Controller
0x0000EFA0-0x0000EFBF	Intel® SMBus - A323
0x0000FFF8-0x0000FFFF	Intel® Active Management Technology - SOL (COM8)

Memory Map

MEMORY MAP	ASSIGNMENT
0xFED10000-0xFED17FFF	Motherboard resources
0xFED18000-0xFED18FFF	Motherboard resources
0xFED19000-0xFED19FFF	Motherboard resources
0xE0000000-0xFFFFFFFF	Motherboard resources
0xFED20000-0xFED3FFFF	Motherboard resources
0xFED90000-0xFED93FFF	Motherboard resources
0xFED45000-0xFED8FFFF	Motherboard resources
0xFEE00000-0xFEEFFFFFFF	Motherboard resources
0xA1100000-0xA111FFFF	Intel® I210 Gigabit Network Connection
0xA1100000-0xA111FFFF	Intel® PCI Express Root Port #11 - A332
0xA1120000-0xA1123FFF	Intel® I210 Gigabit Network Connection
0xFED00000-0xFED003FF	High precision event timer
0xA1220000-0xA122FFFF	Intel® USB 3.1 eXtensible Host Controller - 1.10 (Microsoft)
0xFE1DD000-0xFE1DDFFF	Intel® Serial IO I2C Host Controller - A369
0xFD000000-0xFD69FFFF	Motherboard resources
0xFD6C0000-0xFD6CFFFF	Motherboard resources
0xFD6F0000-0xFDFFFFFFF	Motherboard resources
0xFE000000-0xFE01FFFF	Motherboard resources
0xFE200000-0xFE7FFFFFFF	Motherboard resources
0xFF000000-0xFFFFFFFF	Motherboard resources
0x90000000-0xDFFFFFFF	PCI Express Root Complex
0x90000000-0xDFFFFFFF	Intel® UHD Graphics P630
0xFC800000-0xFE7FFFFFFF	PCI Express Root Complex
0xA1234000-0xA1235FFF	Standard SATA AHCI Controller
0xA123A000-0xA123A0FF	Standard SATA AHCI Controller
0xA1239000-0xA12397FF	Standard SATA AHCI Controller
0xFE010000-0xFE010FFF	Intel® SPI (flash) Controller - A324
0xFE1DF000-0xFE1DFFFF	Intel® Active Management Technology - SOL (COM8)
0xFED40000-0xFED44FFF	Trusted Platform Module 2.0
0xFE1DC000-0xFE1DCFFF	Intel® Management Engine Interface

MEMORY MAP	ASSIGNMENT
0xFE1DE000-0xFE1DEFFF	Intel® Serial IO I2C Host Controller - A368
0xA0000000-0xA0FFFFFF	Intel® UHD Graphics P630
0xFE1E0000-0xFE1FFFFFF	Intel® Ethernet Connection (7) I219-LM
0xFD6E0000-0xFD6EFFFF	Intel® Serial IO GPIO Host Controller - INT3450
0xFD6D0000-0xFD6DFFFF	Intel® Serial IO GPIO Host Controller - INT3450
0xFD6B0000-0xFD6BFFFF	Intel® Serial IO GPIO Host Controller - INT3450
0xFD6A0000-0xFD6AFFFF	Intel® Serial IO GPIO Host Controller - INT3450
0xFE1D8000-0xFE1DBFFF	High Definition Audio Controller
0xFCF00000-0xFCFFFFFF	High Definition Audio Controller
0xA1238000-0xA12380FF	Intel® SMBus - A323
0xA0000-0xBFFFF	PCI Express Root Complex
0xE0000-0xE3FFF	PCI Express Root Complex
0xE4000-0xE7FFF	PCI Express Root Complex
0xE8000-0xEBFFF	PCI Express Root Complex
0xEC000-0xEFFFF	PCI Express Root Complex
0xF0000-0xFFFFF	PCI Express Root Complex
0x40000000-0x403FFFFFF	Motherboard resources

DMA Map

DMA MAP	ASSIGNMENT
Channel 3	Printer Port (LPT1)

Configuring WatchDog Timer

The I/O port address of the watchdog timer is 2E (hex) and 2F (hex). 2E (hex) is the address port. 2F (hex) is the data port. Users must first assign the address of register by writing address value into address port 2E (hex), then write/read data to/from the assigned register through data port 2F (hex).

Configuration Sequence

To program F81966 configuration registers, the following configuration sequence must be followed:

(1) Enter the extended function mode

To place the chip into the Extended Function Mode, two successive writes of 0x87 must be applied to Extended Function Enable Registers (EFERs, i.e. 2Eh or 4Eh).

(2) Configure the configuration registers

The chip selects the Logical Device and activates the desired Logical Devices through Extended Function Index Register (EFIR) and Extended Function Data Register (EFDR). The EFIR is located at the same address as the EFER, and the EFDR is located at address (EFIR+1). First, write the Logical Device Number (i.e. 0x07) to the EFIR and then write the number of the desired Logical Device to the EFDR. If accessing the Chip (Global) Control Registers, this step is not required. Secondly, write the address of the desired configuration register within the Logical Device to the EFIR and then write (or read) the desired configuration register through the EFDR.

(3) Exit the extended function mode

To exit the Extended Function Mode, writing 0xAA to the EFER is required. Once the chip exits the Extended Function Mode, it is in the normal running mode and is ready to enter the configuration mode.

Code example for watch dog timer

Enable watchdog timer and set timeout interval to 30 seconds.

```

; ----- Enter to extended function mode -----
mov    dx,    2Eh
mov    al,    87h
out    dx,    al
out    dx,    al
; ----- Select Logical Device 7 of watchdog timer -----
mov    al,    07h
out    dx,    al
inc    dx
mov    al,    07h
out    dx,    al
; ----- Enable Watch dog feature -----
dec    dx
mov    al,    30h
out    dx,    al
inc    dx
mov    al,    01h
out    dx,    al
; ----- Set timeout interval as 30seconds and start counting -----
dec    dx
mov    al,    F6h
out    dx,    al
inc    dx
mov    al,    1Eh
out    dx,    al
; ----- Enable Watch PME -----
dec    dx
mov    al,    FAh
out    dx,    al
inc    dx
in     al,    dx
or     al,    51h
out    dx,    al
; ----- Set second as counting unit -----
dec    dx
mov    al,    F5h
out    dx,    al
inc    dx
in     al,    dx
and    al,    DEh
out    dx,    al
; ----- Start the watchdog timer -----
or     al,    20h
out    dx,    al
; ----- Exit the extended function mode -----
dec    dx
mov    al,    AAh
out    dx,    al

```

Flash BIOS Update

I. Prerequisites

- 1 Prepare a bootable media (e.g. USB storage device) which can boot system to EFI Shell.
Note: Copy UEFI Shell into the storage device under specific directory path. (/efi/boot/bootx64.efi)
- 2 Download and save the BIOS file (e.g. D0250PQ1.bin) to the bootable device.
- 3 Copy AMI flash utility – AfuEfix64.efi (v5.13.00.05) into bootable device.
- 4 Make sure the target system can first boot to the bootable device.
 - (1) Connect the bootable USB device.
 - (2) Turn on the computer and press <ESC> or during boot to enter BIOS Setup.
 - (3) Select [**Boot**] menu and set the USB bootable device as the 1st boot device.
 - (4) Press <F4> to save the configuration and exit the BIOS setup menu.

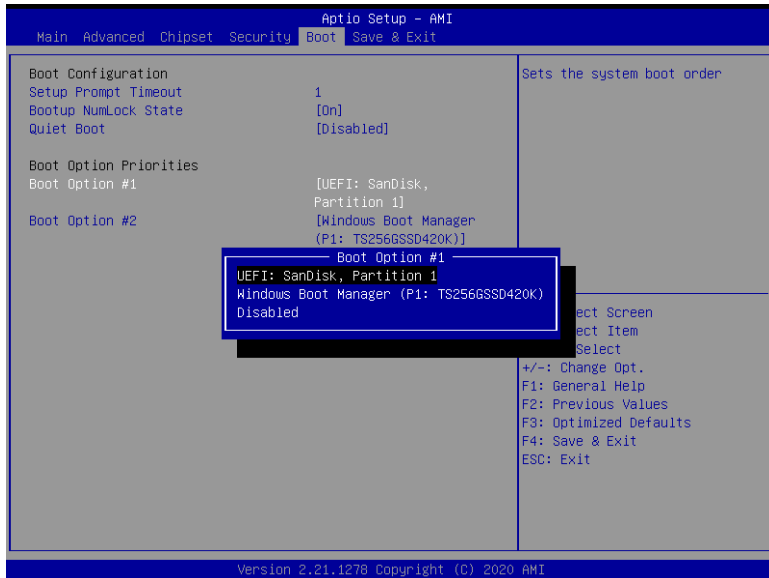

II. AFUEFI Command For System BIOS Update

AfuEfix64.efi is the AMI firmware update utility. The command line is shown as below:

AfuEfix64 <ROM File Name> [option1] [option2]....

Users can type “**AfuEfix64/ ?**” to view the definition of each control option. The recommended options for BIOS ROM update include the following parameters:

- /P**: Program main BIOS image.
- /B**: Program Boot Block.
- /N**: Program NVRAM.
- /X**: Don't check ROM ID.

III. BIOS Update Procedure

- 1** Use the bootable USB storage to boot up the system into the EFI Shell.
- 2** Type "**AfuEfix64 D025xxxx.bin /p /b /n /x**" and press "Enter" to start the flash procedure. (xxxx means the BIOS revision part, e.g. 0PQ1...)
- 3** During the update procedure, you will see the BIOS update process status and its percentage. Beware! **DO NOT** turn off the system power or reset your computer if the whole procedure is not completed yet, or it may crash the BIOS ROM and make the system unable to boot up next time.
- 4** After BIOS update procedure is completed, the messages below will display:

```
fs0:\> afuefix64 D0250PQ1.bin /p /b /n /x
+-----+
|               AMI Firmware Update Utility v5.13.00.05               |
|   Copyright (C) 1985-2020, American Megatrends International LLC.   |
|   All rights reserved. Subject to AMI licensing agreement.         |
+-----+
Reading flash ..... done
- FFS checksums ..... ok
Erasing Boot Block ..... done
Updating Boot Block ..... done
Verifying Boot Block ..... done
Erasing Main Block ..... done
Updating Main Block ..... done
Verifying Main Block ..... done
Erasing NVRAM Block ..... done
Updating NVRAM Block ..... done
Verifying NVRAM Block ..... done
fs0:\>
```

- 5 Restart the system and boot up with the new BIOS configurations.
- 6 The BIOS Update is completed after the system is restarted.
- 7 Reboot the system and verify if the BIOS version shown on the initialization screen has been updated.

